



www.Source1Parts.com

TCGD SERIES - MICROCHANNEL 13 SEER AIR CONDITIONER - R22 (STYLE A)

HVAC SERVICE PARTS

Supersedes:035-21332-001 Rev. E (0308)

035-21332-001 Rev. F (0609)

1 of 4

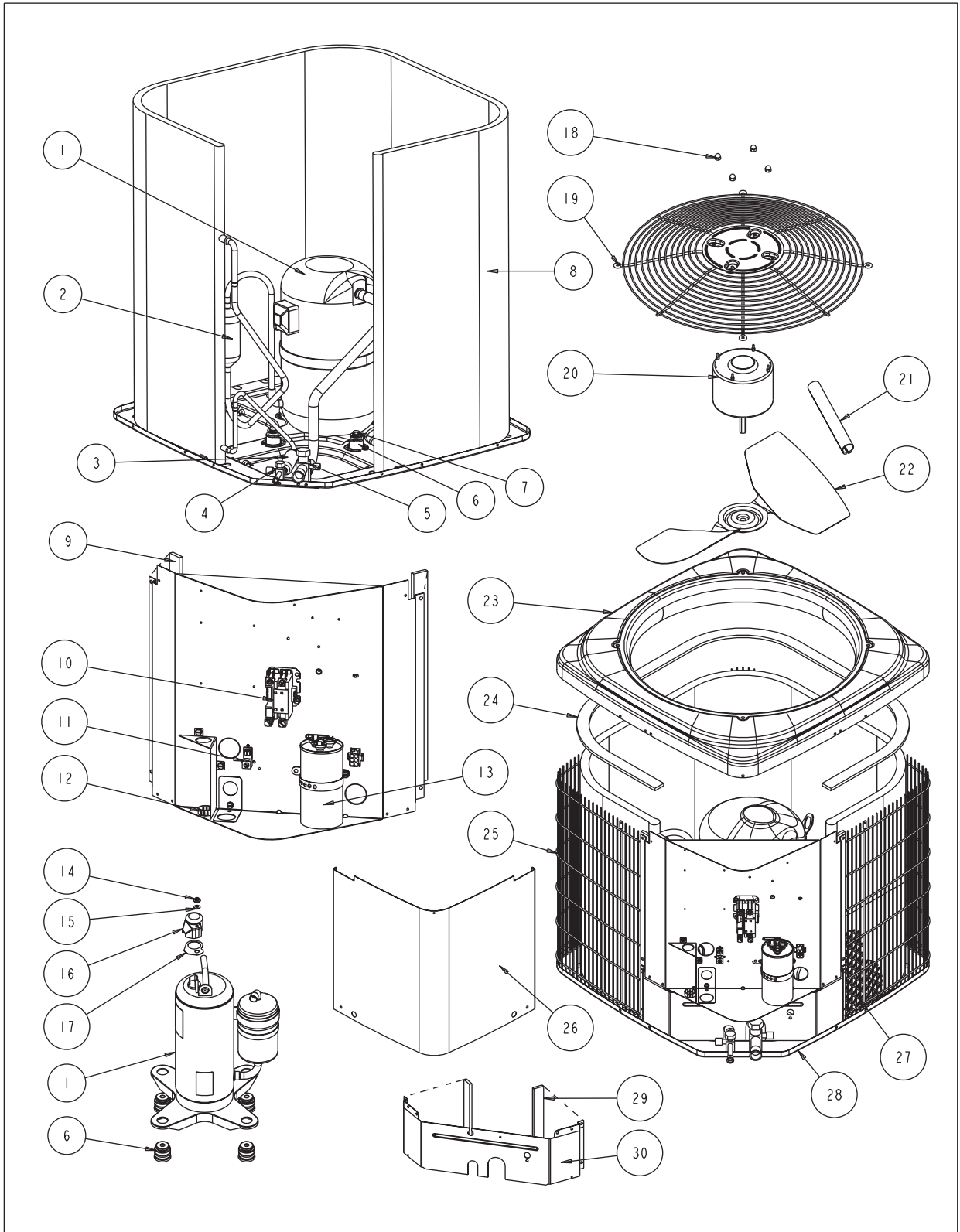

ITEM	DESCRIPTION	TCGD12S21S1A	TCGD18S21S1A	TCGD24S21S1A	TCGD30S21S1A
1	Compressor	S1-01503980007	S1-01503858007	S1-01503981007	S1-01503822001
2	Muffler	---	---	---	S1-02539847000
3	Filter Drier	S1-02922156000	S1-02922156000	S1-02922156000	S1-02922156000
4	Base Valve (3/8") (Liquid)	S1-02531899000	S1-02531899000	S1-02531899000	S1-02531899000
5	Base Valve (3/4") (Suction)	S1-02531900000	S1-02531900000	S1-02531900000	S1-02531900000
6	Compressor Mount (Pkg. of 4)	S1-02813397000	S1-02813397000	S1-02813397000	S1-02909519000
7	Compressor Bolt (4 Req'd)	S1-1048-0033	S1-1048-0033	S1-1048-0033	S1-1048-0033
8	Outdoor Coil Assembly	S1-37323897001	S1-37323897004	S1-37323897004	S1-37323897002
9#	Foam Strips, Control Box (2 Req'd) (14" Control Box)	---	S1-02815491000	S1-02815491000	S1-02815491000
	Foam Strips, Control Box (2 Req'd) (10" Control Box)	S1-02815490000	S1-02815490000	S1-02815490000	S1-02815490000
10	Contactora (30 amp)	S1-02427531000	S1-02427531000	S1-02427531000	S1-02427531000
11	Lug, Ground	S1-02521798000	S1-02521798000	S1-02521798000	S1-02521798000
12	Relief, Strain	S1-02522638000	S1-02522638000	S1-02522638000	S1-02522638000
13	Dual Capacitor (40/5 MFD)	S1-02425893700	---	---	---
	Dual Capacitor (35/5 MFD)	---	S1-02423998700	---	---
	Dual Capacitor (45/5 MFD)	---	---	S1-02425895700	---
	Dual Capacitor (30/5 MFD)	---	---	---	S1-02424778700
14	Hex Nut, Flange	S1-02118373000	S1-02118373000	S1-02118373000	---
15	Gasket, Flange Nut	S1-02814700000	S1-02814700000	S1-02814700000	---
16	Cover, Terminal	S1-02815233000	S1-02815233000	S1-02815233000	---
17	Gasket, Terminal Cover	S1-02815234000	S1-02815234000	S1-02815234000	---
18	Kit, Motor Mounting (Acorn Nuts)	S1-36390117700	S1-36390117700	S1-36390117700	S1-36390117700
19	Guard, Fan	S1-02642483000	S1-02642483000	S1-02642483000	S1-02642483000
20	Motor, Fan	S1-02435710000	S1-02435710000	S1-02435328000	S1-02435328000
21	Wireway	S1-02815485000	S1-02815485000	S1-02815485000	S1-02815485000
22	Blade, Fan	S1-02642490000	S1-02637314000	S1-02637315000	S1-02637315000
23	Top	S1-07323893001	S1-07323893001	S1-07323893001	S1-07323893001
24	Foam, Outdoor Coil	S1-02815488000	S1-02815488000	S1-02815488000	S1-02815488000
25	Guard, Coil (Units Produced on or B4 - 01/16/08)	S1-37323896001	S1-37323896007	S1-37323896007	S1-37323896003
	Guard, Coil (Units Produced After - 01/16/08)	S1-37327821001	S1-37327821003	S1-37327821003	S1-37327821005
26#	Cover, Control Box (14" Box)	---	S1-07323895002	S1-07323895002	S1-07323895002
	Cover, Control Box (10" Box)	S1-07323895001	S1-07323895001	S1-07323895001	S1-07323895001
27	Coil Guard, Plastic Mesh	S1-02642485000	S1-02642492000	S1-02642492000	S1-02642486000
28	Pan, Base	S1-07323894001	S1-07323894001	S1-07323894001	S1-07323894001
29#	Foam Strips, Blockoff (2 Req'd) (14" Control Box)	---	S1-02815492000	S1-02815492000	S1-02815493000
	Foam Strips, Blockoff (2 Req'd) (10" Control Box)	S1-02815492000	S1-02815493000	S1-02815493000	S1-02815522000
30#	Panel, Blockoff (used w/14" Control Box)	---	S1-07323898001	S1-07323898001	S1-07323898002
	Panel, Blockoff (used w/10" Control Box)	S1-07323898001	S1-07323898002	S1-07323898002	S1-07327832003
31*	Orifice (.041)	S1-02211502000	---	---	---
	Orifice (.052)	---	S1-02211503000	---	---
	Orifice (.059)	---	---	S1-02919387010	---
	Orifice (.061)	---	---	S1-02919387003	---
	Orifice (.065)	---	---	---	S1-02919387011
32*	Bezel Plate	S1-02815487000	S1-02815487000	S1-02815487000	S1-02815487000
33*	Harness, Main Wiring	S1-37320055004	S1-37320055004	S1-37320055004	S1-37320055004
34*	Harness, Compressor	---	---	---	S1-02531884000
35*	Wiring Diagram	167242	167242	167242	167242
36*	Compressor Blanket	---	---	S1-01006758000	---

NOTE: *Not Shown
 New replacement parts shown in **bold** face type at the first printing of parts list dated 6/09.
 Major components and suggested stocking items are shown with shaded item number.
 "<" Across from row indicates a change in that row.
 --- Not applicable to specified model.
 # See special note on page 4.

ITEM	DESCRIPTION	TCGD36S21S1A	TCGD42S21S1A	TCGD48S21S1A	TCGD60S21S1A
1	Compressor	S1-01503823001	S1-01503815001	S1-01503839001	S1-01503842004
2	Muffler	S1-02539847000	S1-02539847000	S1-02539847000	---
3	Filter Drier	S1-02922156000	S1-02922157000	S1-02922157000	S1-02922157000
4	Base Valve (3/8") (Liquid)	S1-02531899000	S1-02531899000	S1-02531899000	S1-02531899000
5	Base Valve (3/4") (Suction)	S1-02531900000	---	---	---
	Base Valve (7/8") (Suction)	---	S1-02531901000	S1-02531901000	---
	Base Valve (1 1/8") (Suction)	---	---	---	S1-02318363000
6	Compressor Mount (Pkg. of 4)	S1-02909519000	S1-02909519000	S1-02909519000	S1-02812355000
7	Compressor Bolt (4 Req'd)	S1-1048-0033	S1-1048-0033	S1-1048-0033	S1-1048-0033
8	Outdoor Coil Assembly	S1-37323897005	S1-37323897003	S1-37323897003	S1-37327806001
9#	Foam Strips, Control Box (2 Req'd) (14" Control Box)	S1-02815491000	S1-02815491000	S1-02815491000	S1-02815491000
	Foam Strips, Control Box (2 Req'd) (10" Control Box)	S1-02815490000	S1-02815490000	S1-02815490000	S1-02815490000
10	Contactora (30 amp)	S1-02427531000	S1-02427531000	S1-02427531000	---
	Contactora (40 amp)	---	---	---	S1-02425837700
11	Lug, Ground	S1-02521798000	S1-02521798000	S1-02521798000	S1-02521798000
12	Relief, Strain	S1-02522638000	S1-02522638000	S1-02522638000	S1-02522638000
13	Dual Capacitor (40/5 MFD)	S1-02425893700	---	---	---
	Dual Capacitor (45/5 MFD)	---	S1-02425895700	S1-02425895700	---
	Dual Capacitor (70/5 MFD)	---	---	---	S1-02427616000
14	Hex Nut, Flange	---	---	---	---
15	Gasket, Flange Nut	---	---	---	---
16	Cover, Terminal	---	---	---	---
17	Gasket, Terminal Cover	---	---	---	---
18	Kit, Motor Mounting (Acorn Nuts)	S1-36390117700	S1-36390117700	S1-36390117700	S1-36390117700
19	Guard, Fan	S1-02642483000	S1-02642487000	S1-02642487000	S1-02642487000
20	Motor, Fan	S1-02426020000	S1-02427596000	S1-02427596000	S1-02427596000
21	Wireway	S1-02815485000	S1-02815486000	S1-02815486000	S1-02815486000
22	Blade, Fan	S1-02634092000	S1-02634593000	S1-02642491000	S1-02634094000
23	Top	S1-07323893001	S1-07323893002	S1-07323893002	S1-07323893002
24	Foam, Outdoor Coil	S1-02815488000	S1-02815489000	S1-02815489000	S1-02815489000
25	Guard, Coil (Units Produced on or B4 - 01/16/08)	S1-37323897009	---	---	---
	Guard, Coil (Units Produced on or B4 - 01/28/08)	---	S1-37323897005	S1-37323897005	S1-37327807001
	Guard, Coil (Units Produced After - 01/16/08)	S1-37327821007	---	---	---
	Guard, Coil (Units Produced After - 01/28/08)	---	S1-37327821010	S1-37327821010	S1-37327821012
26#	Cover, Control Box (14" Box)	S1-07323895002	S1-07323895002	S1-07323895002	S1-07323895002
	Cover, Control Box (10" Box)	S1-07323895001	S1-07323895001	S1-07323895001	S1-07323895001
27	Coil Guard, Plastic Mesh	S1-02642493000	S1-02642489000	S1-02642489000	S1-02642495000
28	Pan, Base	S1-07323894001	S1-07323894002	S1-07323894002	S1-07323894002
29#	Foam Strips, Blockoff (2 Req'd) (14" Control Box)	S1-02815494000	S1-02815494000	S1-02815494000	S1-02815496000
	Foam Strips, Blockoff (2 Req'd) (10" Control Box)	S1-02815523000	S1-02815523000	S1-02815523000	S1-02815524000
30	Panel, Blockoff (used w/14" Control Box)	S1-07323898003	S1-07323898003	S1-07323898003	S1-37327808001
	Panel, Blockoff (used w/10" Control Box)	S1-07327832002	S1-07327832002	S1-07327832002	S1-07327832001
31*	Orifice (.073)	S1-02919387005	---	---	---
	Orifice (.081)	---	S1-02919387012	---	---
	Orifice (.084)	---	---	S1-02919387019	---
	Orifice (.096)	---	---	---	S1-02919387008
32*	Bezel Plate	S1-02815487000	S1-02815487000	S1-02815487000	S1-02815487000
33*	Harness, Main Wiring	S1-37320055004	S1-37320055004	S1-37320055004	S1-37320055004
34*	Harness, Compressor	S1-02531884000	S1-02531884000	S1-02531884000	S1-02531885000
35*	Wiring Diagram	167242	167242	167242	167242

NOTE: *Not ShownNew replacement parts shown in **bold** face type at the first printing of parts list dated 6/09.

Major components and suggested stocking items are shown with shaded item number.

"←" Across from row indicates a change in that row.

--- Not applicable to specified model.

See special note on page 4.

SPECIAL NOTE: These outdoor units may be manufactured with 10” or 14” control boxes. Please note references in items 9, 26, 29, and 30. Please match parts accordingly depending on the size control box your unit was manufactured with.

TO ORDER AUTHORIZED FACTORY REPLACEMENT PARTS - Contact your Source1 HVAC Parts Distributor or visit our website at www.Source1Parts.com for a Distributor and Dealer listing.