



www.Source1Parts.com

AC8 SERIES 18 SEER AIR CONDITIONER - OUTDOOR UNIT (R-410A) (STYLE A)

HVAC SERVICE PARTS

Supersedes:035-21383-001 Rev. E (1108)

035-21383-001 Rev. F (0509)

1 of 2

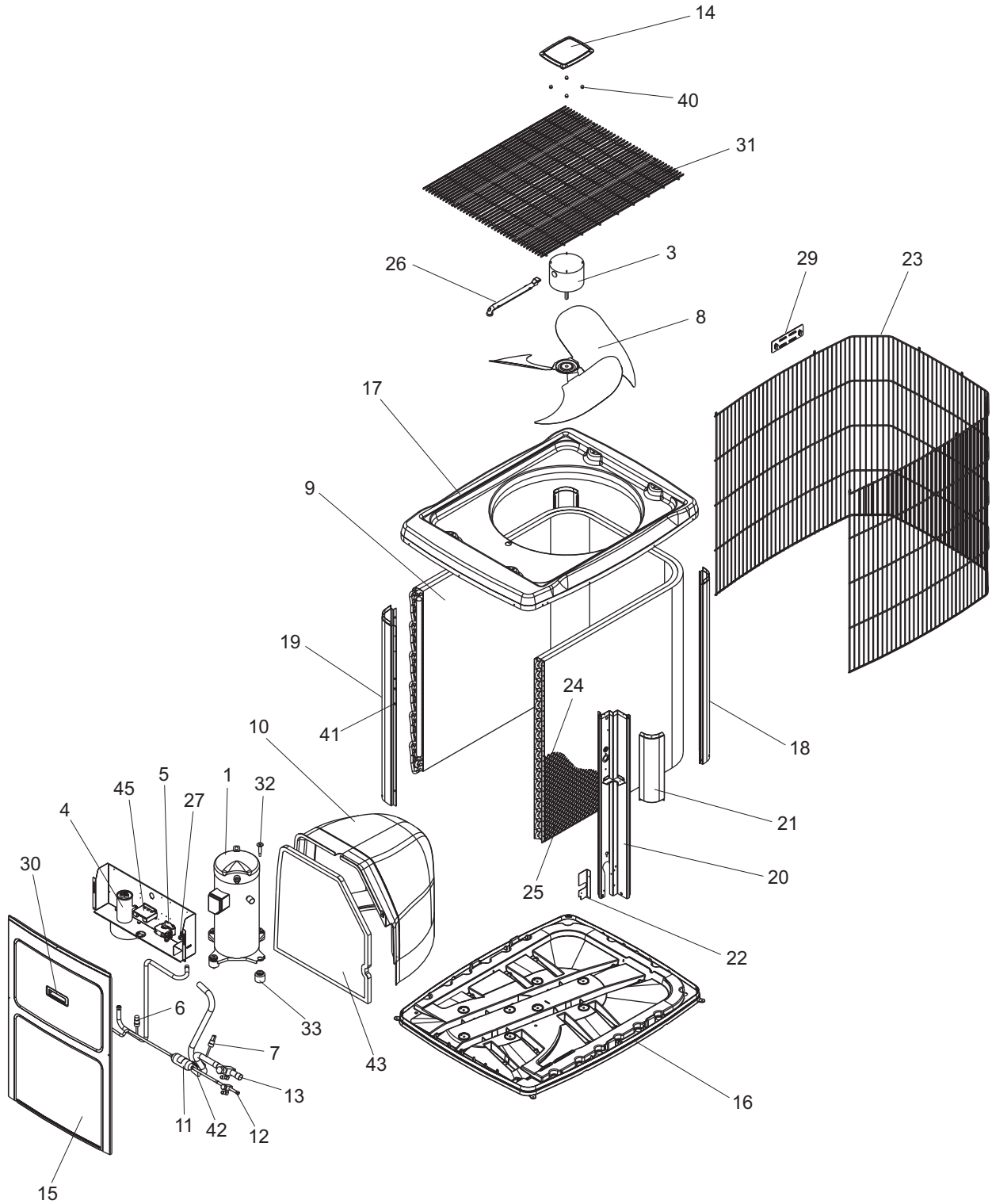

ITEM	DESCRIPTION	AC8B024F1A	AC8B036F1A	AC8B048F1A	AC8B060F1A
1	Compressor	S1-01503668004	S1-01503669004	S1-01503670004	S1-01503671004
2*	Compressor Harness	S1-02531885000	S1-02531885000	S1-02531885000	S1-02531885000
3	Motor, Direct Drive Fan	S1-02434672000	S1-02434672000	S1-02434672000	S1-02434672000
4	Capacitor, Run (35/5MFD) [RC]	S1-02423998700	---	---	---
	Capacitor, Run (40/5MFD) [RC]	---	S1-02425893700	---	---
	Capacitor, Run (45/5MFD) [RC]	---	---	S1-02434672000	---
	Capacitor, Run (80/5MFD) [RC]	---	---	---	S1-02426037000
5	Contact, Electrical (40 AMP) [M]	S1-02425837700	S1-02425837700	S1-02425837700	S1-02425837700
6	Control Pressure (High)	S1-02533305068	S1-02533305068	S1-02533305068	S1-02535359000
7	Control Pressure (Low)	S1-02535360000	S1-02535360000	S1-02535360000	S1-02535360000
8	Blade, Fan	S1-02642370000	S1-02642284000	S1-02642524000	S1-02642524000
9	Coil, Condenser	S1-37327817001	S1-37327817001	S1-37327817002	S1-37327817002
10	Bulkhead, Large	S1-02814887012	S1-02814887012	S1-02814887012	S1-02814887012
11	Filter/Drier	S1-02922195000	S1-02922195000	S1-02922195000	S1-02922195000
12	Valve Base, Liquid (3/8")	S1-02209064375	S1-02209064375	S1-02209064375	S1-02209064375
13	Valve Base, Suction (3/4")	S1-02209064750	S1-02209064750	---	---
	Valve Base, Suction (7/8")	---	---	S1-02209064875	S1-02209064875
14	Top Cap Assy	S1-02814888010	S1-02814888010	S1-02814888010	S1-02814888010
15	Access Panel	S1-07323829004	S1-07323829004	S1-07323829004	S1-07323829004
16	Pan, Base	S1-03200214000	S1-03200214000	S1-03200214000	S1-03200214000
17	Panel, Top (See Note #1)	S1-07327895001	S1-07327895001	S1-07327895001	S1-07327895001
18	Corner Post, Front (2 Req'd)	S1-07326917708	S1-07326917708	S1-07326917708	S1-07326917708
19	Corner Post, Access	S1-07326917711	S1-07326917711	S1-07326917711	S1-07326917711
20	Corner Post, Valve	S1-07326917713	S1-07326917713	S1-07326917713	S1-07326917713
21	Corner Cover, Access	S1-07326917115	S1-07326917115	S1-07326917115	S1-07326917115
22	Bracket, Corner Post	S1-07326917117	S1-07326917117	S1-07326917117	S1-07326917117
23	Coil Guard	S1-07323830002	S1-07323830002	S1-07323830002	S1-07323830002
24	Guard, Plastic Wire Mesh Coil	S1-02815464000	S1-02815464000	S1-02815464000	S1-02815464000
25	Fastener, Push-In (8 Req'd)	S1-02118381000	S1-02118381000	S1-02118381000	S1-02118381000
26	Wireway	S1-02815463000	S1-02815463000	S1-02815463000	S1-02815463000
27	Lug, Electrical	S1-02521798000	S1-02521798000	S1-02521798000	S1-02521798000
28*	Alert, Comfort	S1-02538740000	S1-02538740000	S1-02538740000	S1-02538740000
29*	Bezel Plate Assy (1 Req'd)	S1-02814889001	S1-02814889001	S1-02814889001	S1-02814889001
30	Handle, Access	S1-02814886000	S1-02814886000	S1-02814886000	S1-02814886000
31	Guard, Fan (See Note #1)	S1-02642282000	S1-02642282000	S1-02642282000	S1-02642282000
32	Grommet, Isolator (Comp) (Pkg. of 4)	S1-02810505000	S1-02810505000	S1-02810505000	S1-02810505000
33	Bolt, Compressor (4 Req'd)	S1-02118391000	S1-02118391000	S1-02118391000	S1-02118391000
34*	Screw, Black #10 x 3/8"	S1-02118396000	S1-02118396000	S1-02118396000	S1-02118396000
35*	Screw, Black #10 x 3/4"	S1-02118397000	S1-02118397000	S1-02118397000	S1-02118397000
36*	Screw, #8 x 1-1/2" Torx Head	S1-02118398000	S1-02118398000	S1-02118398000	S1-02118398000
37*	Diagram, Wiring	102771	102771	102771	102771
38*	Wire Harness	S1-37326955007	S1-37326955007	S1-37326955007	S1-37326955007
39*	Wiring Harness, Compressor Solenoid	S1-02538936000	S1-02538936000	S1-02538936000	S1-02538936000
40	Kit, Motor Mounting (Acorn Nuts)	S1-36390117700	S1-36390117700	S1-36390117700	S1-36390117700
41*	Grommet, Plastic (Spacer, 2 Req'd)	S1-02814880000	S1-02814880000	S1-02814880000	S1-02814880000
42*	Grommet, Vibration Reducer (7/8")	S1-02815165003	S1-02815165003	S1-02815165003	S1-02815165003
43*	Insulation Door - Large	S1-01006922007	S1-01006922007	S1-01006922007	S1-01006922007
44*	Grommet, Motor/Fan Guard (4 Req'd)	S1-02815876000	S1-02815876000	S1-02815876000	S1-02815876000

NOTE: *Not ShownNew replacement parts shown in **bold** face type at the first printing of parts list dated 5/09.

Major components and suggested stocking items are shown with shaded item number.

"←" Across from row indicates a change in that row.

--- Not applicable to specified model.

1. Design change - see YS-001-09.

TO ORDER AUTHORIZED FACTORY REPLACEMENT PARTS - Contact your Source1 HVAC Parts Distributor or visit our website at www.Source1Parts.com for a Distributor and Dealer listing.