



www.Source1Parts.com

TCGD SERIES - MICROCHANNEL 13 SEER AIR CONDITIONER - R22 (2ND GENERATION) (STYLE A)

HVAC SERVICE PARTS

Supersedes:035-22033-001 Rev. B (0608)

035-22033-001 Rev. C (0609)

1 of 4

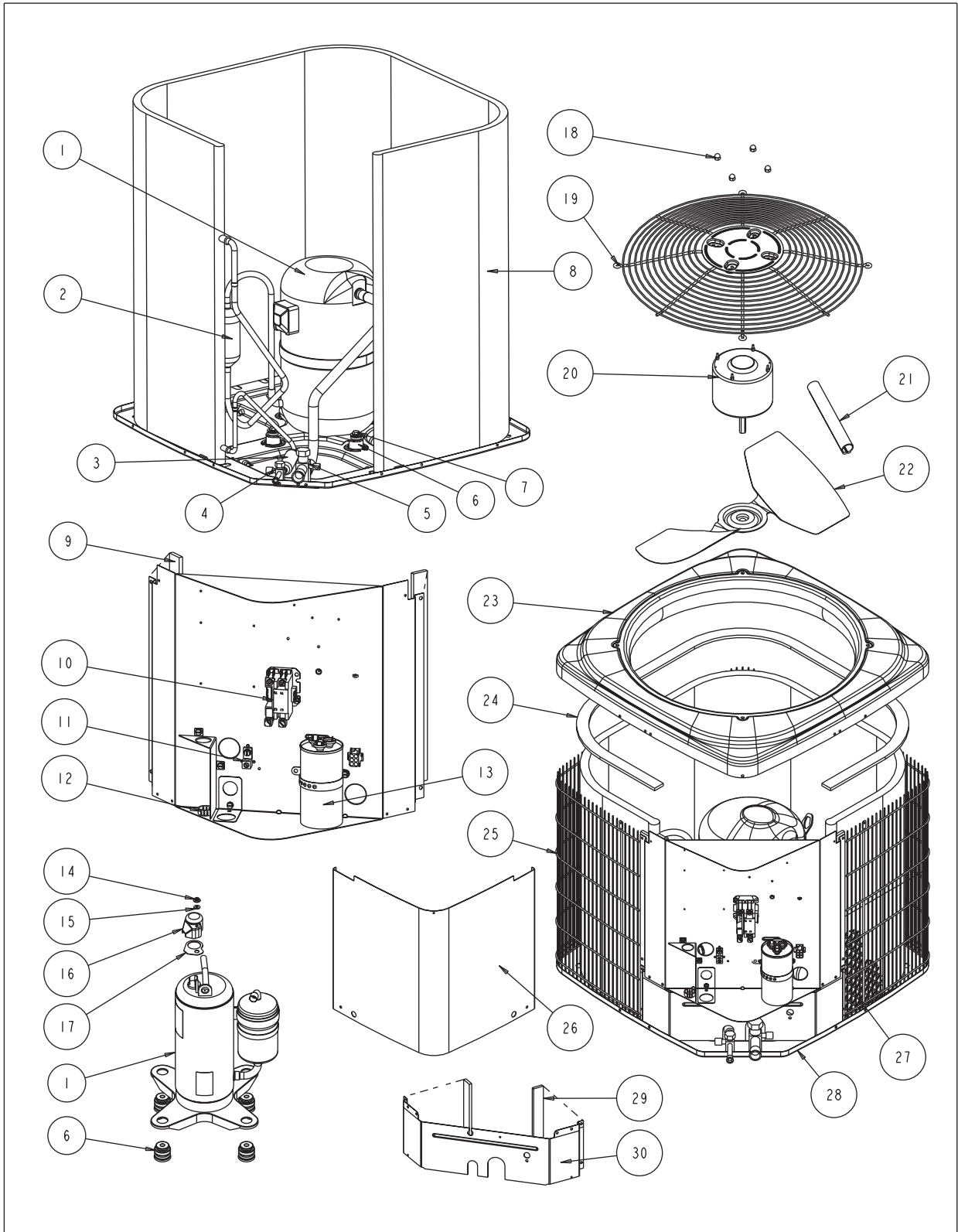

ITEM	DESCRIPTION	TCGD12S21S2A	TCGD18S21S2A	TCGD24S21S2A	TCGD30S21S2A
1	Compressor	S1-01503980007	S1-01503858007	S1-01503981007	S1-01503822001
2	Muffler	---	---	---	S1-02539847000
3	Filter Drier	S1-02922156000	S1-02922156000	S1-02922156000	S1-02922156000
4	Base Valve (3/8") (Liquid)	S1-02531899000	S1-02531899000	S1-02531899000	S1-02531899000
5	Base Valve (3/4") (Suction)	S1-02531900000	S1-02531900000	S1-02531900000	S1-02531900000
6	Compressor Mount (Pkg. of 4)	S1-02813397000	S1-02813397000	S1-02813397000	S1-02809519000
7	Compressor Bolt (4 Req'd)	S1-1048-0033	S1-1048-0033	S1-1048-0033	S1-1048-0033
8	Outdoor Coil Assembly	S1-37323897001	S1-37323897004	S1-37323897004	S1-37323897002
9	Foam Strips, Control Box (2 Req'd)	S1-02815490000	S1-02815490000	S1-02815490000	S1-02815490000
10	Contactora (30 amp)	S1-02427531000	S1-02427531000	S1-02427531000	S1-02427531000
11	Lug, Ground	S1-02521798000	S1-02521798000	S1-02521798000	S1-02521798000
12	Relief, Strain	S1-02522638000	S1-02522638000	S1-02522638000	S1-02522638000
13	Dual Capacitor (40/5 MFD)	S1-02425893700	---	---	---
	Dual Capacitor (35/5 MFD)	---	S1-02423998700	---	---
	Dual Capacitor (45/5 MFD)	---	---	S1-02425895700	---
	Dual Capacitor (30/5 MFD)	---	---	---	S1-02424778700
14	Hex Nut, Flange	S1-02118373000	S1-02118373000	S1-02118373000	---
15	Gasket, Flange Nut	S1-02814700000	S1-02814700000	S1-02814700000	---
16	Cover, Terminal	S1-02815233000	S1-02815233000	S1-02815233000	---
17	Gasket, Terminal Cover	S1-02815234000	S1-02815234000	S1-02815234000	---
18	Kit, Motor Mounting (Acorn Nuts)	S1-36390117700	S1-36390117700	S1-36390117700	S1-36390117700
19	Guard, Fan	S1-02642483000	S1-02642483000	S1-02642483000	S1-02642483000
20	Motor, Fan	S1-02435710000	S1-02435710000	S1-02435328000	S1-02435328000
21	Wireway	S1-02815485000	S1-02815485000	S1-02815485000	S1-02815485000
22	Blade, Fan	S1-02642490000	S1-02637314000	S1-02637315000	S1-02637315000
23	Top	S1-07323893001	S1-07323893001	S1-07323893001	S1-07323893001
24	Foam, Outdoor Coil	S1-02815488000	S1-02815488000	S1-02815488000	S1-02815488000
25	Guard, Coil	S1-37327821001	S1-37327821003	S1-37327821003	S1-37327821005
26	Cover, Control Box	S1-07323895001	S1-07323895001	S1-07323895001	S1-07323895001
27	Coil Guard, Plastic Mesh	S1-02642485000	S1-02642492000	S1-02642492000	S1-02642486000
28	Pan, Base	S1-07323894001	S1-07323894001	S1-07323894001	S1-07323894001
29	Foam Strips, Blockoff (2 Req'd)	S1-02815492000	S1-02815493000	S1-02815493000	S1-02815522000
30	Panel, Blockoff	S1-07323898001	S1-07323898002	S1-07323898002	S1-07327832003
31*	Orifice (.041)	S1-02211502000	---	---	---
	Orifice (.052)	---	S1-02211503000	---	---
	Orifice (.059)	---	---	S1-02919387010	---
	Orifice (.061)	---	---	S1-02919387003	---
	Orifice (.065)	---	---	---	S1-02919387011
32*	Bezel Plate	S1-02815487000	S1-02815487000	S1-02815487000	S1-02815487000
33*	Harness, Main Wiring	S1-37320055004	S1-37320055004	S1-37320055004	S1-37320055004
34*	Harness, Compressor	---	---	---	S1-02531884000
35*	Wiring Diagram	167242	167242	167242	167242
36*	Compressor Blanket	---	---	S1-01006758000	---

<
<
<
<

NOTE: *Not Shown
 New replacement parts shown in **bold** face type at the first printing of parts list dated 6/09.
 Major components and suggested stocking items are shown with shaded item number.
 "<" Across from row indicates a change in that row.
 --- Not applicable to specified model.



ITEM	DESCRIPTION	TCGD36S21S2A	TCGD42S21S2A	TCGD48S21S2A	TCGD60S21S2A
1	Compressor	S1-01503823001	S1-01503815001	S1-01503839001	S1-01503842004
2	Muffler	S1-02539847000	S1-02539847000	S1-02539847000	---
3	Filter Drier	S1-02922156000	S1-02922157000	S1-02922157000	S1-02922157000
4	Base Valve (3/8") (Liquid)	S1-02531899000	S1-02531899000	S1-02531899000	S1-02531899000
5	Base Valve (3/4") (Suction)	S1-02531900000	---	---	---
	Base Valve (7/8") (Suction)	---	S1-02531901000	S1-02531901000	---
	Base Valve (1 1/8") (Suction) (Units produced before 6/20/2008)	---	---	---	S1-02318363000
	Base Valve (7/8") (Suction) (Units produced on or after 6/20/2008)	---	---	---	S1-02211529000
6	Compressor Mount (Pkg. of 4)	S1-02809519000	S1-02809519000	S1-02809519000	S1-02812355000
7	Compressor Bolt (4 Req'd)	S1-1048-0033	S1-1048-0033	S1-1048-0033	S1-1048-0033
8	Outdoor Coil Assembly	S1-37323897005	S1-37323897003	S1-37323897003	S1-37327806001
	Foam Strips, Control Box (2 Req'd)	S1-02815490000	S1-02815490000	S1-02815490000	S1-02815490000
10	Contactora (30 amp)	S1-02427531000	S1-02427531000	S1-02427531000	---
	Contactora (40 amp)	---	---	---	S1-02425837700
11	Lug, Ground	S1-02521798000	S1-02521798000	S1-02521798000	S1-02521798000
12	Relief, Strain	S1-02522638000	S1-02522638000	S1-02522638000	S1-02522638000
13	Dual Capacitor (40/5 MFD)	S1-02425893700	---	---	---
	Dual Capacitor (45/5 MFD)	---	S1-02425895700	S1-02425895700	---
	Dual Capacitor (70/5 MFD)	---	---	---	S1-02427616000
14	Hex Nut, Flange	---	---	---	---
15	Gasket, Flange Nut	---	---	---	---
16	Cover, Terminal	---	---	---	---
17	Gasket, Terminal Cover	---	---	---	---
18	Kit, Motor Mounting (Acorn Nuts)	S1-36390117700	S1-36390117700	S1-36390117700	S1-36390117700
19	Guard, Fan	S1-02642483000	S1-02642487000	S1-02642487000	S1-02642487000
20	Motor, Fan	S1-02426020000	S1-02427596000	S1-02427596000	S1-02427596000
21	Wireway	S1-02815485000	S1-02815486000	S1-02815486000	S1-02815486000
22	Blade, Fan	S1-02634092000	S1-02634593000	S1-02642491000	S1-02634094000
23	Top	S1-07323893001	S1-07323893002	S1-07323893002	S1-07323893002
24	Foam, Outdoor Coil	S1-02815488000	S1-02815489000	S1-02815489000	S1-02815489000
25	Guard, Coil	S1-37327821007	S1-37327821010	S1-37327821010	S1-37327821012
26	Cover, Control Box	S1-07323895001	S1-07323895001	S1-07323895001	S1-07323895001
27	Coil Guard, Plastic Mesh	S1-02642493000	S1-02642489000	S1-02642489000	S1-02642495000
28	Pan, Base	S1-07323894001	S1-07323894002	S1-07323894002	S1-07323894002
29	Foam Strips, Blockoff (2 Req'd)	S1-02815523000	S1-02815523000	S1-02815523000	S1-02815524000
30	Panel, Blockoff	S1-07327832002	S1-07327832002	S1-07327832002	S1-07327832001
31*	Orifice (.073)	S1-02919387005	---	---	---
	Orifice (.081)	---	S1-02919387012	---	---
	Orifice (.084)	---	---	S1-02919387019	---
	Orifice (.096)	---	---	---	S1-02919387008
32*	Bezel Plate	S1-02815487000	S1-02815487000	S1-02815487000	S1-02815487000
33*	Harness, Main Wiring	S1-37320055004	S1-37320055004	S1-37320055004	S1-37320055004
34*	Harness, Compressor	S1-02531884000	S1-02531884000	S1-02531884000	S1-02531885000
35*	Wiring Diagram	167242	167242	167242	167242

NOTE: *Not Shown

New replacement parts shown in **bold** face type at the first printing of parts list dated 6/09.

Major components and suggested stocking items are shown with shaded item number.

"<" Across from row indicates a change in that row.

--- Not applicable to specified model.

TO ORDER AUTHORIZED FACTORY REPLACEMENT PARTS - Contact your Source1 HVAC Parts Distributor or visit our website at www.Source1Parts.com for a Distributor and Dealer listing.