



www.Source1Parts.com

TCJF SERIES - MICROCHANNEL 14.5 SEER AIR CONDITIONER - R410A (STYLE A)

HVAC SERVICE PARTS

Supersedes: Nothing

035-22751-001 Rev. A (0909)

1 of 4

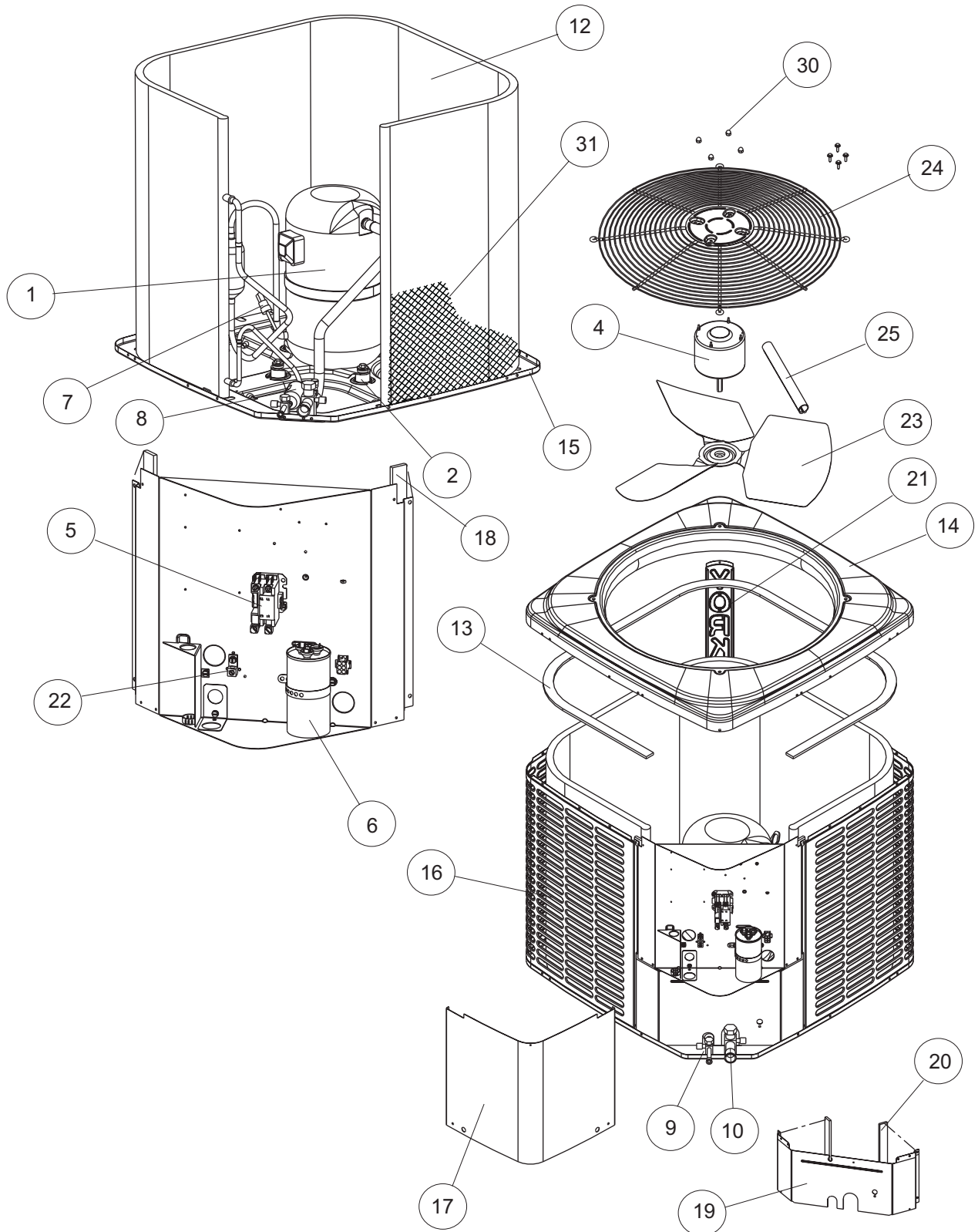

ITEM	DESCRIPTION	TCJF24S41S3A	TCJF30S41S3A	TCJF36S41S3A	<
1	Compressor	S1-01504149004	S1-01504147004	S1-01504146004	
2	Compressor Mount (Pkg. of 4)	S1-02812355000	S1-02812355000	S1-02812355000	
3*	Harness, Compressor	S1-02541088000	S1-02541088000	S1-02541088000	
4	Motor, Fan	S1-02435328000	S1-02435328000	S1-02435819000	
5	Contactora (30 amp)	S1-02427531000	S1-02427531000	S1-02427531000	
6	Dual Capacitor (40/5 MFD)	S1-02425893700	S1-02425893700	---	
	Dual Capacitor (45/5 MFD)	---	---	S1-02425895700	
7	Pressure Switch (High)	S1-02535359000	S1-02535359000	S1-02535359000	
8	Filter Drier	S1-02922195000	S1-02922195000	S1-02922195000	
9	Base Valve (3/8") (Liquid)	S1-02531899000	S1-02531899000	S1-02531899000	
10	Base Valve (3/4") (Suction)	S1-02531900000	S1-02531900000	S1-02531900000	
11					
12	Outdoor Coil Assembly	S1-37327820002	S1-37327869001	S1-37327869001	
13	Foam, Outdoor Coil	S1-02815509000	S1-02815509000	S1-02815509000	
14	Top	S1-07327834002	S1-07327834002	S1-07327834002	
15	Pan, Base	S1-07323894002	S1-07323894002	S1-07323894002	
16	Guard Coil, Panel (2 Req'd)	S1-07327906002	S1-07327906009	S1-07327906009	
17	Cover, Control Box	S1-07327837001	S1-07327837001	S1-07327837001	
18	Foam Strips, Control Box (2 Req'd)	S1-02815490000	S1-02815490000	S1-02815490000	
19	Panel, Block-off	S1-07327836001	S1-07327858002	S1-07327858002	
20	Foam Strips, Block-off (2 Req'd)	S1-02815493000	S1-02815493000	S1-02815493000	
21	Post, Corner	S1-07327835003	S1-07327857002	S1-07327857002	
22	Lug, Ground	S1-02521798000	S1-02521798000	S1-02521798000	
23	Blade, Fan	S1-02642445000	S1-02642445000	S1-02642611000	
24	Guard, Fan	S1-02642487000	S1-02642487000	S1-02642487000	
25	Wireway	S1-02815873000	S1-02815873000	S1-0281587000	
26*	Blanket, Compressor	S1-01007636000	S1-01007636000	S1-01007636000	
27*	Fasteners, Push-in (4 Req'd)	S1-02118381000	S1-02118381000	S1-02118381000	
28*	Coil Mount, Rubber (6 Req'd)	S1-02815500000	S1-02815500000	S1-02815500000	
29*	Plate, Bezel	S1-02815899000	S1-02815899000	S1-02815899000	
30	Kit, Motor Mounting (Acorn Nuts)	S1-36390117700	S1-36390117700	S1-36390117700	
31	Coil Guard, Plastic Mesh	S1-02642547000	S1-02642612000	S1-02642612000	
32*	Harness, Main Wiring	S1-37320055004	S1-37320055004	S1-37320055004	
33	Wiring Diagram	167242	167242	167242	

NOTE: *Not ShownNew replacement parts shown in **bold** face type at the first printing of parts list dated 9/09.

Major components and suggested stocking items are shown with shaded item number.

"←" Across from row indicates a change in that row.

--- Not applicable to specified model.

ITEM	DESCRIPTION	TCJF42S41S3A	TCJF48S41S3A	TCJF60S41S3A	<
1	Compressor	S1-01503894004	S1-01503593004	S1-01504148004	
2	Compressor Mount (Pkg. of 4)	S1-02812355000	S1-02812355000	S1-02812355000	
3*	Harness, Compressor	S1-02541088000	S1-02531884000	S1-02531884000	
4	Motor, Fan	S1-02435819000	S1-02435819000	S1-02435819000	
5	Contactor (30 amp)	S1-02427531000	S1-02427531000	---	
	Contactor (40 amp)	---	---	S1-02425837700	
6	Dual Capacitor (45/5 MFD)	S1-02425895700	---	---	
	Dual Capacitor (60/5 MFD)	---	S1-02425033700	S1-02425033700	
7	Pressure Switch (High)	S1-02535359000	S1-02535359000	S1-02535359000	
8	Filter Drier	S1-02922195000	S1-02922195000	S1-02922195000	
9	Base Valve (3/8") (Liquid)	S1-02531899000	S1-02531899000	S1-02531899000	
10	Base Valve (7/8") (Suction)	S1-02531901000	S1-02531901000	S1-02531901000	
11					
12	Outdoor Coil Assembly	S1-37327869002	S1-37327869003	S1-37327869004	
13	Foam, Outdoor Coil	S1-02815863000	S1-02815863000	S1-02815863000	
14	Top	S1-07327853001	S1-07327853001	S1-07327853001	
15	Pan, Base	S1-07327844002	S1-07327844002	S1-07327844002	
16	Guard Coil, Panel (2 Req'd)	S1-07327906008	S1-07327906006	S1-07327906009	
17	Cover, Control Box	S1-07327837001	S1-07327837001	S1-07327827001	
18	Foam Strips, Control Box (2 Req'd)	S1-02815490000	S1-02815490000	S1-02815490000	
19	Panel, Block-off	S1-07327862001	S1-07327858002	S1-07327862002	
20	Foam Strips, Block-off (2 Req'd)	S1-02815523000	S1-02815496000	S1-02815524000	
21	Post, Corner	S1-07327861002	S1-07327857002	S1-07327857003	
22	Lug, Ground	S1-02521798000	S1-02521798000	S1-02521798000	
23	Blade, Fan	S1-02642370000	S1-02642370000	S1-02642370000	
24	Guard, Fan	S1-02642586000	S1-02642586000	S1-02642586000	
25	Wireway	S1-02815864000	S1-02815864000	S1-02815864000	
26*	Blanket, Compressor	S1-01007637000	S1-01007635000	S1-01007642000	
27*	Fasteners, Push-in (4 Req'd)	S1-02118381000	S1-02118381000	S1-02118381000	
28*	Coil Mount, Rubber (6 Req'd)	S1-02815500000	S1-02815500000	S1-02815500000	
29*	Plate, Bezel	S1-02815899000	S1-02815899000	S1-02815899000	
30	Kit, Motor Mounting (Acorn Nuts)	S1-36390117700	S1-36390117700	S1-36390117700	
31	Coil Guard, Plastic Mesh	S1-02642613000	S1-02642614000	S1-02842617000	
32*	Harness, Main Wiring	S1-37320055004	S1-37320055004	S1-37320055004	
33*	Wiring Diagram	167242	167242	167242	

NOTE: *Not ShownNew replacement parts shown in **bold** face type at the first printing of parts list dated 9/09.

Major components and suggested stocking items are shown with shaded item number.

"←" Across from row indicates a change in that row.

--- Not applicable to specified model.



TO ORDER AUTHORIZED FACTORY REPLACEMENT PARTS - Contact your Source1 HVAC Parts Distributor or visit our website at www.Source1Parts.com for a Distributor and Dealer listing.