



www.Source1Parts.com

# TCGD SERIES - MICROCHANNEL 13 SEER AIR CONDITIONER - R410A 3RD GENERATION (STYLE A)

HVAC SERVICE PARTS

Supersedes:Nothing

035-22783-001 Rev. A (0909)

1 of 4

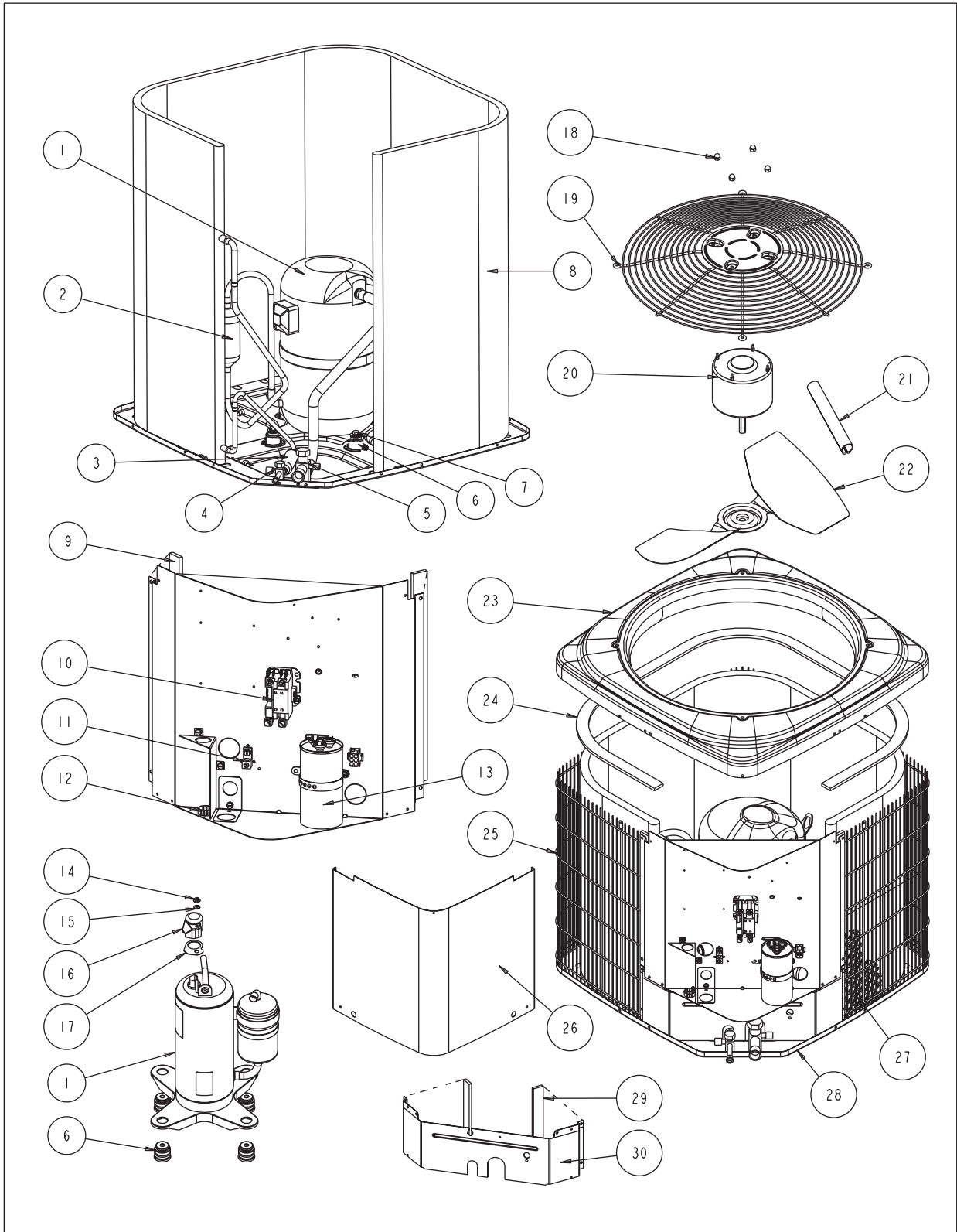

ITEM	DESCRIPTION	TCGD18S41S3A	TCGD24S41S3A	TCGD30S41S3A	TCGD36S41S3A <
1	Compressor	S1-01504075004	S1-01504076004	S1-01504077004	S1-01504078004
2	Muffler	---	---	---	---
3	Filter Drier	S1-02922195000	S1-02922195000	S1-02922195000	S1-02922195000
4	Base Valve (3/8") (Liquid)	S1-02531899000	S1-02531899000	S1-02531899000	S1-02531899000
5	Base Valve (3/4") (Suction)	S1-02531900000	S1-02531900000	S1-02531900000	S1-02531900000
6	Compressor Mount (Pkg. of 4)	S1-02813397000	S1-02809519000	S1-02809519000	S1-02809519000
7	Compressor Bolt (4 Req'd)	S1-1048-0033	S1-1048-0033	S1-1048-0033	S1-1048-0033
8	Outdoor Coil Assembly	S1-37327820001	S1-37327820001	S1-37327820001	S1-37327820002
9	Foam Strips, Control Box (2 Req'd)	S1-02815490000	S1-02815490000	S1-02815490000	S1-02815490000
10	Contactors (30 amp)	S1-02427531000	S1-02427531000	S1-02427531000	S1-02427531000
11	Lug, Ground	S1-02521798000	S1-02521798000	S1-02521798000	S1-02521798000
12	Relief, Strain	S1-02522638000	S1-02522638000	S1-02522638000	S1-02522638000
13	Dual Capacitor (35/5 MFD)	S1-02423998700	S1-02423998700	S1-02423998700	---
	Dual Capacitor (40/5 MFD)	---	---	---	S1-02425893700
14	Hex Nut, Flange	S1-02118373000	---	---	---
15	Gasket, Flange Nut	S1-02814700000	---	---	---
16	Cover, Terminal	S1-02815233000	---	---	---
17	Gasket, Terminal Cover	S1-02815234000	---	---	---
18	Kit, Motor Mounting (Acorn Nuts)	S1-36390117700	S1-36390117700	S1-36390117700	S1-36390117700
19	Guard, Fan	S1-02642483000	S1-02642483000	S1-02642483000	S1-02642487000
20	Motor, Fan	S1-02435710000	S1-02435328000	S1-02426020700	S1-02435819000
21	Wireway	S1-02815877000	S1-02815877000	S1-02815877000	S1-02815873000
22	Blade, Fan	S1-02642490000	S1-02642444000	S1-02642444000	S1-02634094000
23	Top	S1-07323893001	S1-07323893001	S1-07323893001	S1-07323893002
24	Molded Foam (A) (Outdoor Coil)	S1-02815508000	S1-02815508000	S1-02815508000	S1-02815509000
25	Guard, Coil	S1-07327903004	S1-07327903004	S1-07327903004	S1-07327903005
26	Cover, Control Box	S1-07323895001	S1-07323895001	S1-07323895001	S1-07323895001
27	Coil Guard, Plastic Mesh	S1-02642492000	S1-02642492000	S1-02642492000	S1-02642547000
28	Pan, Base	S1-07323894001	S1-07323894001	S1-07323894001	S1-07323894002
29	Foam Strips, Blockoff (2 Req'd)	S1-02815493000	S1-02815493000	S1-02815493000	S1-02815493000
30	Panel, Blockoff	S1-07323898002	S1-07323898002	S1-07323898002	S1-07323898002
31*	Orifice (.048)	S1-02919387038	---	---	---
	Orifice (.055)	---	S1-02919837014	---	---
	Orifice (.061)	---	---	S1-02919837003	---
	Orifice (.065)	---	---	---	S1-02919387011
32*	Bezel Plate	S1-02815487000	S1-02815487000	S1-02815487000	S1-02815487000
33*	Harness, Main Wiring	S1-37320055004	S1-37320055004	S1-37320055004	S1-37320055004
34*	Harness, Compressor	---	S1-02531884000	S1-02531884000	S1-02531884000
35*	Wiring Diagram	167242	167242	167242	167242
36*	Fastener, Push-In (6 Req'd)	S1-02118381000	S1-02118381000	S1-02118381000	S1-02118381000
37*	Switch, Pressure	S1-02535359000	S1-02535359000	S1-02535359000	S1-02535359000
38*	Rubber Mount, Outdoor Coil (6 Req'd)	S1-02815500000	S1-02815500000	S1-02815500000	S1-02815500000

**NOTE:** \*Not Shown  
 New replacement parts shown in **bold** face type at the first printing of parts list dated 9/09.  
 Major components and suggested stocking items are shown with shaded item number.  
 "<" Across from row indicates a change in that row.  
 --- Not applicable to specified model.

ITEM	DESCRIPTION	TCGD42S41S3A	TCGD48S41S3A	TCGD60S41S3A	<
1	Compressor	S1-01504079004	S1-01504080004	S1-01503595004	
2	Muffler	S1-02539847000	S1-02539847000	---	
3	Filter Drier	S1-02922195000	S1-02922195000	S1-02922195000	
4	Base Valve (3/8") (Liquid)	S1-02531899000	S1-02531899000	S1-02531899000	
5	Base Valve (7/8") (Suction)	S1-02531901000	S1-02531901000	S1-02531901000	
6	Compressor Mount (Pkg. of 4)	S1-02809519000	S1-02809519000	S1-02812355000	
7	Compressor Bolt (4 Req'd)	S1-1048-0033	S1-1048-0033	S1-1048-0033	
8	Outdoor Coil Assembly	S1-37327820003	S1-37327820003	S1-37327851001	
9	Foam Strips, Control Box (2 Req'd)	S1-02815490000	S1-02815490000	S1-02815490000	
10	Contactora (30 amp)	S1-02427531000	S1-02427531000	---	
	Contactora (40 amp)	---	---	S1-02425837700	
11	Lug, Ground	S1-02521798000	S1-02521798000	S1-02521798000	
12	Relief, Strain	S1-02522638000	S1-02522638000	S1-02522638000	
13	Dual Capacitor (45/5 MFD)	S1-02425120700	S1-02425120700	---	
	Dual Capacitor (70/5 MFD)	---	---	S1-02427616000	
14	Hex Nut, Flange	---	---	---	
15	Gasket, Flange Nut	---	---	---	
16	Cover, Terminal	---	---	---	
17	Gasket, Terminal Cover	---	---	---	
18	Kit, Motor Mounting (Acorn Nuts)	S1-36390117700	S1-36390117700	S1-36390117700	
19	Guard, Fan	S1-02642487000	S1-02642487000	S1-02642586000	
20	Motor, Fan	S1-02435819000	S1-02435819000	S1-02435819000	
21	Wireway	S1-02815873000	S1-02815873000	S1-02815864000	
22	Blade, Fan	S1-02642491000	S1-02642491000	S1-02631361000	
23	Top	S1-07323893002	S1-07323893002	S1-07327844001	
24	Molded Foam, (B) Outdoor Coil	S1-02815509000	S1-02815509000	S1-02815863000	
25	Guard, Coil	S1-07327903005	S1-07327903005	S1-07327903001	
26	Cover, Control Box	S1-07323895001	S1-07323895001	S1-07323895001	
27	Coil Guard, Plastic Mesh	S1-02642546000	S1-02642546000	S1-02815868000	
28	Pan, Base	S1-07323894002	S1-07323894002	S1-07327844002	
29	Foam Strips, Blockoff (2 Req'd)	S1-02815494000	S1-02815494000	S1-02815522000	
30	Panel, Blockoff	S1-07323898003	S1-07323898003	S1-07327832003	
31*	Orifice (.075)	S1-02919837017	---	---	
	Orifice (.073)	---	S1-02919387005	---	
	Orifice (.087)	---	---	S1-02919387007	
32*	Bezel Plate	S1-02815487000	S1-02815487000	S1-02815487000	
33*	Harness, Main Wiring	S1-37320055004	S1-37320055004	S1-37320055004	
34*	Harness, Compressor	S1-02531884000	S1-02531884000	S1-02531884000	
35*	Wiring Diagram	167242	167242	167242	
36*	Fastener, Push-In (6 Req'd)	S1-02118381000	S1-02118381000	S1-02118381000	
37*	Switch, Pressure	S1-02535359000	S1-02535359000	S1-02535359000	
38*	Rubber Mount, Outdoor Coil (6 Req'd)	S1-02815500000	S1-02815500000	S1-02815500000	

**NOTE:** \*Not ShownNew replacement parts shown in **bold** face type at the first printing of parts list dated 9/09.

Major components and suggested stocking items are shown with shaded item number.

"&lt;" Across from row indicates a change in that row.

--- Not applicable to specified model.

**TO ORDER AUTHORIZED FACTORY REPLACEMENT PARTS** - Contact your Source1 HVAC Parts Distributor or visit our website at [www.Source1Parts.com](http://www.Source1Parts.com) for a Distributor and Dealer listing.