

# TECHNICAL GUIDE

## SPLIT-SYSTEM

## AIR-COOLED

## CONDENSING UNITS

## MODELS: HF-07

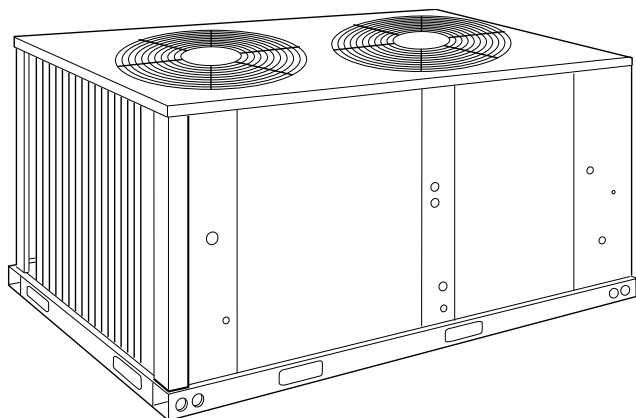

## DESCRIPTION

These Sunline 2000 units are completely assembled, piped and wired at the factory to provide one-piece shipment and rigging. Each unit is pressurized with a holding charge of Refrigerant-22 for storage and/or shipping.

The compact design, clean styling, low silhouette, and quiet operation make these condensing units suitable for almost any outdoor location. On rooftops, because they weigh much less than a single package unit of similar capacity and are much easier to rig and support. At ground level, because their ample sub-cooling capacity allows them to be located 60 feet below the evaporator coil.

All sheet metal parts are constructed of commercial grade (G90) galvanized steel. After fabrication, each part is thoroughly cleaned to remove any grease or dirt from its surfaces. The external parts are coated with a powder paint to assure a quality finish for many years. This UL approved coating system has passed the 750 hour, 20% salt spray test per ASTM Standard B117.

All models include a 1-year limited warranty on the complete unit. The compressor carries an additional 4-year warranty.

A complete line of Evaporator Blower units is also offered to meet your precise capacity and air handling requirements. Refer to Form 036-21300-001 for more information on this air side equipment.

## FEATURES

- Condenser coil constructed of copper tubes and aluminum fins for durability and long lasting efficient operation.
- Permanently attached base rails with fork-lift slots and lifting holes. This design allows for 3-way fork-lift access and overhead rigging.
- Both high and low pressure controls. Since these controls are self-contained, there are no capillary lines to be damaged.
- Compressor line-break motor protection and crankcase heaters.
- Anti-short cycle timer to protect the compressor.
- A lockout circuit to prevent the unit from cycling on safety control.
- A 24-volt temperature control circuit.
- Low ambient operation to 45°F accessories for 0°F low ambient operation are available.
- A filter-drier (shipped in the unit's compressor compartment for field installation near the evaporator coil).
- Service valves with a back-seating access port for pressure testing the system. Copper stub-outs are factory mounted on the suction and liquid service valves to simplify the field piping connections.
- Separate panel for easy access to the control box without affecting air flow across the condenser coil.
- Gauge lines extend out from cabinet to facilitate servicing.
- Packaging suitable for outdoor storage
- Optional coil guard accessory protect coils with a decorative grille.



208/230/460  
VOLT ONLY



208/230/575  
VOLT ONLY

## TABLE OF CONTENTS

<b>DESCRIPTION</b> .....	<b>1</b>
<b>FEATURES</b> .....	<b>1</b>
<b>SEQUENCE OF OPERATION</b> .....	<b>7</b>
<b>GUIDE SPECIFICATIONS</b> .....	<b>11</b>

### LIST OF FIGURES

<u>Fig. #</u>	<u>Pg. #</u>
1 TYPICAL FIELD WIRING WITH AIR HANDLER .....	8
2 4 POINT LOADS .....	8
3 TYPICAL FIELD WIRING WITH 7-1/2 TON FURNACE .....	9
4 CENTER OF GRAVITY .....	10
5 UNIT DIMENSIONS & CLEARANCES HF-07 .....	10

### LIST OF TABLES

<u>Tbl. #</u>		<u>Pg. #</u>
1	ARI RATINGS .....	3
2	APPLICATION DATA .....	3
3	PHYSICAL DATA .....	3
4	ELECTRICAL DATA .....	4
5	UNIT COOLING CAPACITIES AND POWER REQUIREMENTS .....	4
6	SYSTEM COOLING CAPACITIES AND POWER REQUIREMENTS (HF-07/LF-07) .....	5
7	HF-07 CHARGING CURVE .....	6
8	MINIMUM CLEARANCES .....	9

**TABLE 1: ARI RATINGS\***

CONDENSING UNIT MODEL	INDOOR BLOWER UNIT MODEL	SYSTEM MBH	SYSTEM EER	CONDENSING UNIT SOUND LEVEL(bels)
HF-07	LF-07	90	10.7	8.9

\*. Certified in accordance with Unitary Large Equipment certification program, which is based on ARI Standard 340/360.

**TABLE 2: APPLICATION DATA**

LIMITATION		MIN.	MAX.
Voltage Variation *	208/230-3-60	187V	252V
	460-3-60	432V	504V
	575-3-60	540V	630V
Ambient Air on Condenser Coil		45°F†	125°F

\*. Rated in accordance with ARI Standard 110, utilization range "A".

†. Low Ambient accessories are available to permit stable system operation at ambient temperatures down to 0°F.

Note: Refer to Form 035-15407-001 for refrigerant piping limitations.

**TABLE 3: PHYSICAL DATA**

Model HF	Compressor		Condenser												Unit Weight (Lbs.)		Charge, Lbs.-Oz. (Refrigerant-22)	
			Fan (Propeller)				Fan Motor *				Coils†							
	Rating (Tons)	Cap. (Stages)	Qty.	Dia. (in.)	Norm CFM	Blades		Qty.	RPM	HP	Rotation‡	Face Area‡	Finned Length (in.)	Rows High	Ship.	Oper.	Holding	Oper.**
-07	7-1/2	1	2	24	7800	3	26	2	1110	3/4	CW	23.8	96	36	388	383	1-12	14.95

\*. These PSC motors are directly connected to the condenser fans and have inherent protection, ball bearings and a 48" frame.

†. These condenser coils have 2 rows of 3/8" OD copper tubes and 16 aluminum fins per inch.

‡. When viewing the shaft end of the motor.

\*\* Includes matched indoor blower unit but no piping.

TABLE 4: ELECTRICAL DATA

MODEL HF	VOLTAGE CODE	COMPRESSOR			CONDENSER FAN MOTOR				UNIT AMPACITY (AMPS)	MAX. FUSE SIZE* (AMPS)	MIN. WIRE SIZE† (AWG)
		POWER SUPPLY	RLA	LRA	POWER SUPPLY	HP	QTY	FLA			
-07	2	208/230-3-60	25.6	190	208/230-1-60	3/4	2	3.03	38.1	60	8
	4	460-3-60	12.8	95	460-1-60	3/4	2	1.60	19.2	30	10
	5	575-3-60	10.2	75	575-1-60	3/4	2	1.35	15.5	25	10

\*. Dual element.

†. Based on three, 60°C insulated copper conductors in steel conduit.

TABLE 5: UNIT COOLING CAPACITIES AND POWER REQUIREMENTS

Model HF	Suction Press. & Corresponding Temp. @ Saturation		Temperature of Air on Condenser Coil, °F											
			65		75		85		95		105		115	
	PSIG	°F	MBH	KW*	MBH	KW*	MBH	KW*	MBH	KW*	MBH	KW*	MBH	KW*
-07	61.6	35	94	6.7	90	7.2	85	7.8	80	8.3	75	9.1	70	9.8
	68.5	40	104	6.8	99	7.3	94	7.9	89	8.5	84	9.2	78	9.9
	76.0	45	114	6.8	109	7.4	103	8	98	8.6	93	9.3	87	10
	84.0	50	124	6.9	119	7.5	113	8.1	108	8.7	102	9.4	96	10.2

\*. Includes compressor and condenser fan motor(s).

**TABLE 6: SYSTEM COOLING CAPACITIES AND POWER REQUIREMENTS (HF-07/LF-07)**

Air On Evaporator Coil		Temperature of on Air Condenser Coil																			
		85 °F								95 °F											
		Total Capacity (MBh)	Total Input (kW)	Sensible Capacity (MBh)								Total Capacity (MBh)	Total Input (kW)	Sensible Capacity (MBh)							
				Return Dry Bulb (°F)										Return Dry Bulb (°F)							
CFM	WB(°F)	86	83	80	77	74	71	68	86	83	80	77	74	71	68						
2250	72	99	7.1	58	51	45	38	32	-	-	95	7.7	56	49	43	37	30	-	-		
	67	90	6.9	70	63	57	50	44	38	31	87	7.6	68	62	55	49	43	36	30		
	62	83	6.7	80	74	68	61	55	48	42	80	7.4	78	72	65	59	52	46	40		
	57	79	6.6	79	79	72	66	59	53	47	76	7.3	76	76	69	63	56	50	44		
2625	72	102	7.1	63	55	48	40	32	-	-	98	7.8	61	54	46	39	31	-	-		
	67	93	7.0	76	68	60	53	45	38	30	90	7.6	75	67	60	52	44	37	29		
	62	85	6.8	84	79	72	64	57	49	42	82	7.5	82	78	70	63	55	47	40		
	57	81	6.7	81	81	77	69	62	54	47	79	7.4	79	79	74	67	59	52	44		
3000	72	105	7.2	68	59	51	42	33	-	-	101	7.8	67	58	50	41	32	-	-		
	67	96	7.0	82	73	64	55	47	38	29	93	7.6	81	73	64	55	46	38	29		
	62	88	6.8	88	85	76	68	59	50	41	85	7.5	85	84	75	66	58	49	40		
	57	84	6.7	84	84	82	73	64	55	47	81	7.4	81	81	80	71	62	53	45		
3300	72	106	7.2	72	63	53	43	33	-	-	103	7.8	71	62	52	42	32	-	-		
	67	97	7.0	87	77	67	57	48	38	28	95	7.7	86	76	67	57	47	37	28		
	62	89	6.9	89	88	80	70	60	51	41	87	7.5	87	86	79	69	59	49	40		
	57	85	6.7	85	85	84	74	65	55	45	83	7.4	83	83	82	72	63	53	43		
3600	72	108	7.2	77	66	55	45	34	-	-	105	7.9	76	65	54	43	33	-	-		
	67	99	7.0	92	81	70	59	49	38	27	97	7.7	91	80	70	59	48	37	27		
	62	91	6.9	91	91	84	73	62	51	41	88	7.6	88	88	82	71	61	50	39		
	57	87	6.7	87	87	87	76	65	54	44	84	7.5	84	84	84	74	63	52	41		

Air On Evaporator Coil		Temperature of Air on Condenser Coil																			
		105 °F								115 °F											
		Total Capacity (MBh)	Total Input (kW)	Sensible Capacity (MBh)								Total Capacity (MBh)	Total Input (kW)	Sensible Capacity (MBh)							
				Return Dry Bulb (°F)										Return Dry Bulb (°F)							
CFM	WB(°F)	86	83	80	77	74	71	68	86	83	80	77	74	71	68						
2250	72	91	8.5	63	56	50	44	37	-	-	88	9.4	70	63	57	50	44	-	-		
	67	84	8.4	67	60	54	48	41	35	28	81	9.2	65	59	52	46	40	33	27		
	62	77	8.2	70	63	57	50	44	38	31	74	9.0	61	55	48	42	35	29	23		
	57	74	8.1	74	74	68	61	55	49	42	72	8.9	72	72	66	60	54	47	41		
2625	72	94	8.6	69	61	54	46	38	-	-	91	9.4	76	68	61	53	46	-	-		
	67	87	8.4	73	65	58	50	43	35	28	84	9.3	71	64	56	48	41	33	26		
	62	80	8.3	74	69	61	53	46	38	31	77	9.1	67	59	52	44	36	29	21		
	57	77	8.2	77	76	73	65	58	50	42	74	9.0	74	74	71	63	56	48	41		
3000	72	98	8.7	75	66	57	48	40	-	-	94	9.5	82	73	65	56	47	-	-		
	67	90	8.5	79	70	62	53	44	35	27	87	9.3	77	68	60	51	42	33	25		
	62	82	8.3	79	74	65	56	48	39	30	80	9.2	72	64	55	46	37	29	20		
	57	79	8.2	79	79	78	69	60	51	43	77	9.0	77	77	75	67	58	49	40		
3300	72	99	8.7	80	70	60	50	41	-	-	95	9.5	88	78	69	59	49	-	-		
	67	92	8.5	85	75	65	55	46	36	26	88	9.4	83	73	63	54	44	34	24		
	62	84	8.4	82	77	68	59	49	39	29	81	9.2	77	68	58	49	39	29	19		
	57	81	8.3	81	81	80	70	60	51	41	78	9.1	78	78	77	68	58	48	39		
3600	72	101	8.7	85	74	63	53	42	-	-	97	9.5	94	83	73	62	51	-	-		
	67	93	8.6	90	79	68	58	47	36	25	89	9.4	89	78	67	56	46	35	24		
	62	85	8.4	85	80	72	61	50	40	29	82	9.2	82	72	62	51	40	30	19		
	57	82	8.3	82	82	82	71	60	50	39	80	9.1	80	80	80	69	58	47	37		

**TABLE 6: SYSTEM COOLING CAPACITIES AND POWER REQUIREMENTS (HF-07/LF-07) (CONTINUED)**

Air On Evaporator Coil		Temperature of Air on Condenser Coil								
		125 °F								
		Total Capacity (MBh)	Total Input (kW)	Sensible Capacity (MBh)						
				Return Dry Bulb (°F)						
CFM	WB(°F)			86	83	80	77	74	71	68
2250	72	84	10.2	77	70	64	57	51	-	-
	67	77	10.0	64	57	51	45	38	32	25
	62	72	9.8	53	46	40	33	27	21	14
	57	70	9.7	70	70	65	59	52	46	39
2625	72	87	10.2	83	76	68	60	53	-	-
	67	80	10.1	69	62	54	47	39	32	24
	62	74	9.9	59	50	42	35	27	20	12
	57	72	9.8	72	72	69	62	54	46	39
3000	72	90	10.3	90	81	72	63	55	-	-
	67	83	10.2	75	66	58	49	40	31	23
	62	77	10.0	66	54	45	36	27	19	10
	57	75	9.9	75	75	73	65	56	47	38
3300	72	92	10.4	92	87	77	67	58	-	-
	67	84	10.2	81	71	62	52	42	32	23
	62	78	10.0	73	59	48	38	29	19	9
	57	76	9.9	76	76	75	65	56	46	36
3600	72	93	10.4	93	93	82	71	61	-	-
	67	86	10.2	86	77	66	55	44	34	23
	62	79	10.0	79	65	52	41	30	19	9
	57	77	9.9	77	77	77	66	56	45	34

**TABLE 7: HF-07 CHARGING CURVE**

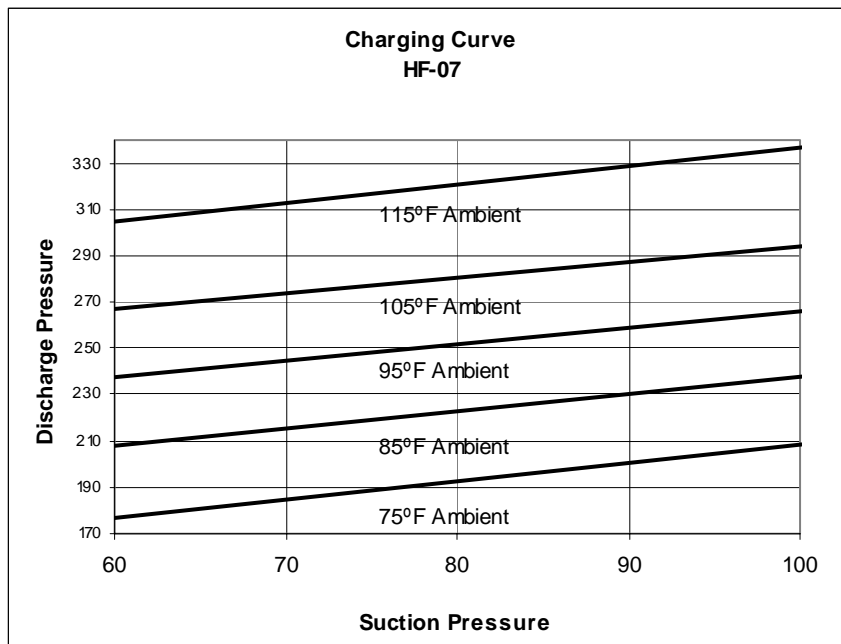

## SEQUENCE OF OPERATION

### UNIT OPERATION - 7-1/2 TON

#### When the external control calls for cooling at terminal Y1:

The system controller (SC) is energized. The system controller starts the tandem compressors and enables the condenser fans by energizing contactor 1M (2M on the 208/230 volt models).

Condenser fan motor #1 is energized with the compressor. Fan motor #2 operation is controlled through the Pressure Switch (PS) which will de-energize the motor when the discharge pressure falls below 180 psi.

Safety Lockout: The system controller (SC) has a lockout circuit to prevent compressor short-cycling on a safety control with automatic reset. If the high or low refrigerant pressure switches (HP or LP) open, the SC will enter lockout mode.

SC provides a 90 second bypass of the low pressure switch LP to prevent nuisance lockouts during unit start-up.

A malfunction light (24V, 2 A max. resistive load) can be energized through SC, by connecting the light between terminals X and B on TB1.

**NOTE:** To reset the unit after a lockout:

- a. Turn the system switch on the thermostat to the "OFF" position and back to the "COOL" position.

OR

- b. Increase the set point of the room thermostat above the temperature in the conditioned space and return it to its original setting. If the unit continues to be shut down by one of its safety controls, a service man should be called to determine the cause of the problem. Repeated resetting of the lockout circuit may damage the unit.

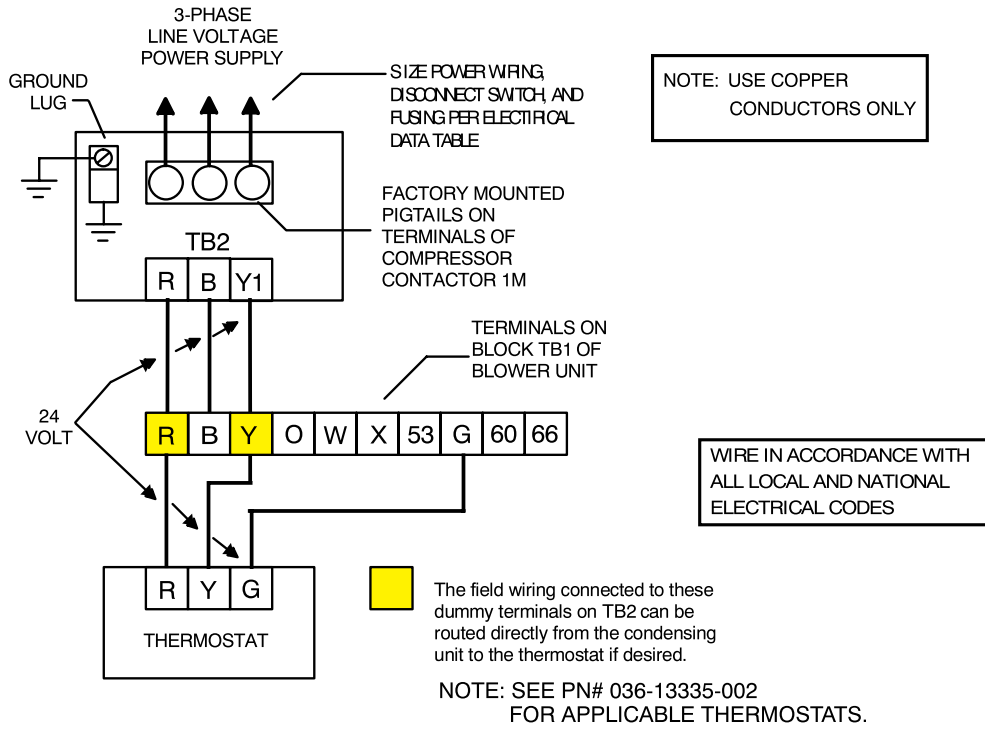
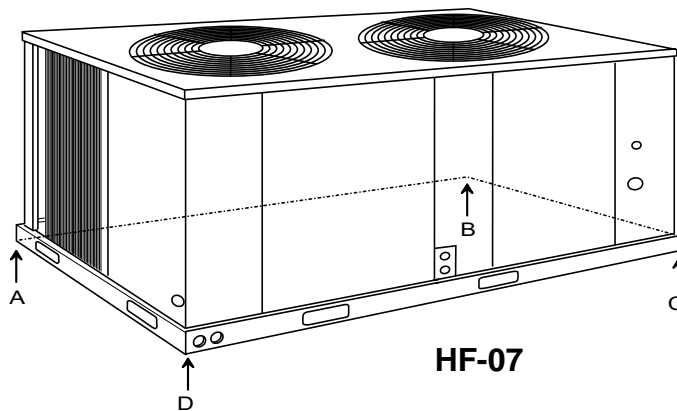
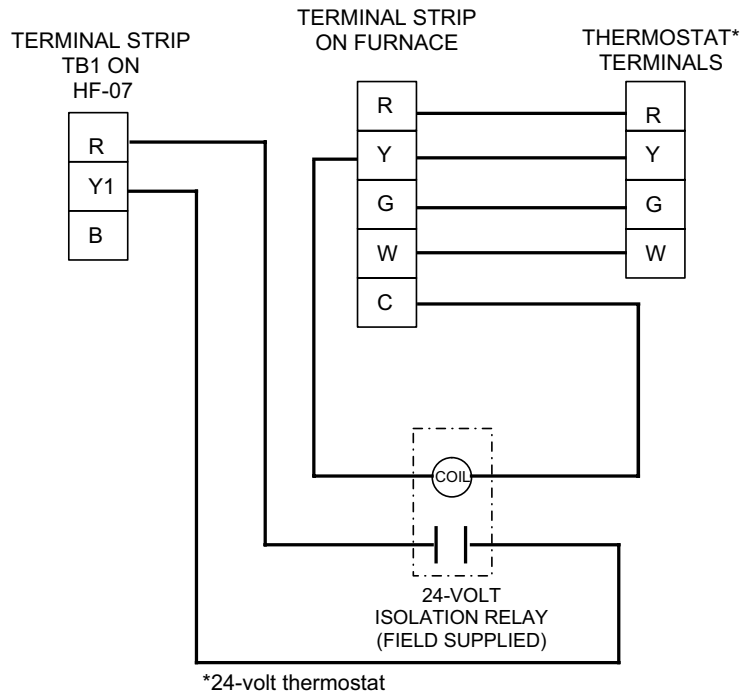

FIGURE 1 - TYPICAL FIELD WIRING WITH AIR HANDLER



UNIT	4-POINT LOAD (lbs)				
	Total	A	B	C	D
HF-07	383	83	115	107	78

FIGURE 2 - 4 POINT LOADS



**FIELD-INSTALLED ACCESSORIES - 0°F LOW AMBIENT KITS** - An auto-transformer and temperature control maintain stable system operation by reducing the speed of the condenser fan motor.

**FIGURE 3- TYPICAL FIELD WIRING WITH 7-1/2 TON FURNACE**

**CLEARANCES**

All units require certain minimum clearances for proper operation and service. Refer to Figure 5 for these clearances.

**TABLE 8: MINIMUM CLEARANCES**

CLEARANCE DESCRIPTION	DISTANCE IN INCHES
Overhead (Top)	120
Front (Access Cover)	36
Rear	24
Left Side	30
Right Side	30

**CAUTION**

Do not permit overhanging structures or shrubs to obstruct condenser air discharge.

Additional height may be required for snow clearance if winter operation is expected.

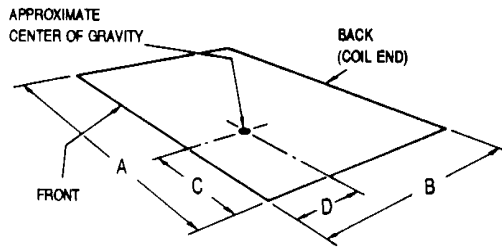

UNIT	DIM (In.)			
	A	B	C	D
7-1/2 Ton.	70-1/8	32	29-5/8	16-1/12

All dimensions are in inches. They are subject to change without notice. Certified dimensions will be provided upon request.

FIGURE 4- CENTER OF GRAVITY

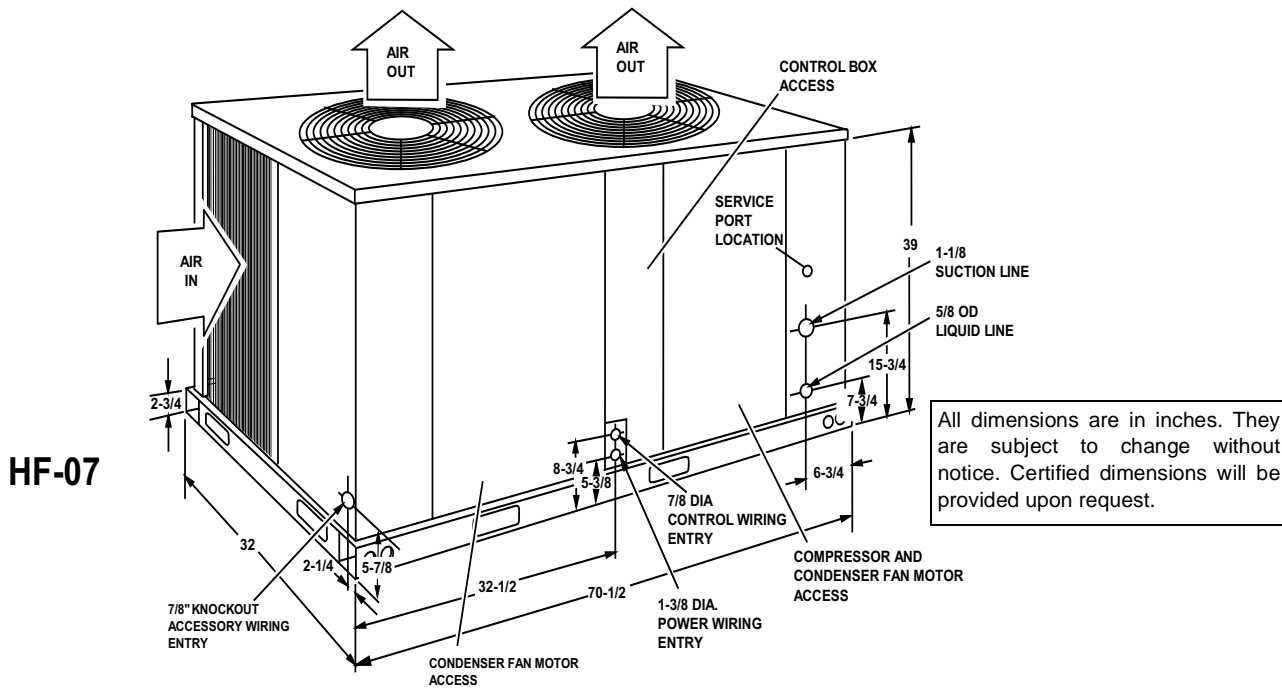

All dimensions are in inches. They are subject to change without notice. Certified dimensions will be provided upon request.

FIGURE 5- UNIT DIMENSIONS & CLEARANCES HF-07

## GUIDE SPECIFICATIONS

Furnish and install UPG air-cooled condensing units or equivalent, suitable for ground or roof mounting. Units shall have capacities and efficiencies as outlined in the schedules shown on the plans and shall be installed in accordance with all applicable national and local codes.

### I. GENERAL

- a. Units shall be manufactured in a facility registered under the ISO 9002 manufacturing quality standard.
- b. Units shall be UL and CSA approved.
- c. Unit shall be packaged to allow outdoor storage.
- d. Hermetic compressors shall be covered by a five year limited warranty.
- e. All other unit parts shall be covered by a full year limited warranty.

### II. UNIT CABINET

- a. Cabinet shall be constructed of 18 gauge, zinc-coated steel, finished with a powder paint process capable of withstanding a minimum of 750 salt spray hours according to ASTM B117.
- b. Cabinet screws shall comply with the ASTM B117 salt spray test for a minimum of 750 hours.
- c. Panels shall be removable for easy access to all internal components during maintenance and service.
- d. Cabinet shall feature a separate access panel for the controls so that unit airflow need not be disturbed during servicing.
- e. Permanently attached base rails shall have 3-way fork lift access and lifting holes for ease of installation.

### III. COMPRESSOR

- a. Compressor shall be a scroll compressor with integral motor overload protection.
- b. Compressors shall have an integral crankcase heater to keep refrigerant from diluting the compressor oil in the sump. Crankcase heater shall be field replaceable without removal of the charge.
- c. Compressor shall be mounted on isolators to limit the transmission of sound and vibration.

### IV. CONDENSER AND FANS

- a. Fan motors shall be single phase, direct-drive with propeller-type condenser fans which discharge air vertically upward.
- b. Units with more than one condenser fan motor shall be wired to distribute the single phase motor loads across the 3 phase power supply, thus minimizing phase imbalance on multiple unit installations.
- c. Fan motors shall be totally enclosed with permanently lubricated ball-bearings for longer wear during start and stop cycles.

- d. Fan motors shall have inherent overload protection.
- e. Coil shall be constructed of rifled copper tubing mechanically expanded and bonded to louvered aluminum fins. Coil shall include an integral subcooler.

### V. REFRIGERATION COMPONENTS

- a. Refrigeration system contains both high and low pressure cut-outs.
- b. Service valves to ease installation and recovery of refrigerant.
- c. External ports to accommodate gauge lines, allowing for easy servicing of the unit.
- d. Each unit ships with a filter drier for field installation.
- e. Holding charge of R-22.

### VI. CONTROLS

- a. Each unit is equipped with 24 volt control circuit with terminal blocks.
- b. Color-coded wiring for easy service and trouble shooting.
- c. Independent line break thermal protection for the condenser fans.
- d. 5 minute anti-short cycle timer to protect the compressor from frequent cycling.
- e. Unit safety lockouts which automatically reset from the thermostat once the anti-short cycle timer is satisfied. Safety lockouts will also generate a 24 volt signal to the "X" terminal, allowing notification to the user via the thermostat fault light (if present). These safety lockouts shall include:
  - High refrigerant pressure.
  - Low refrigerant pressure (low refrigerant pressure shall be bypassed for the first 90 seconds of operation to eliminate nuisance trips).
  - Compressor motor protection to automatically shut-down the unit in the event of motor overcurrent or excessive temperature conditions. Unit shall automatically restart after the line break protector cools.
  - Low ambient operation down to 45°F (7°C) without a low ambient kit. (Operation down to 0°F with the optional low ambient kit.)

### VII. ELECTRICAL

- a. Units shall be \_\_\_\_\_ volts, 3 phase, with a single power point connection.
- b. Unit control circuit shall have a 24 volt transformer, sized sufficiently to operate the indoor fan.
- c. All condenser fan motors and the secondary of each transformer shall be grounded.

## VIII. ACCESSORIES AND OPTIONS

- a. Head Pressure Control
- b. Shall include a condenser fan motor and an auto transformer to slow the speed of the condenser fan at low ambient temperatures, allowing operation of the condensing unit down to 0°F.

## IX. COIL GUARD

- a. Field installed decorative grille shall be placed on the units to provide further coil protection.
- b. Phenolic Coating on Condenser Coil.
- c. Condenser coils shall be dipped in a four-coat phenolic coating process to provide longer life in corrosive conditions.