

JOB NAME _____ LOCATION _____
PURCHASER _____ ORDER NO. _____
ENGINEER _____
SUBMITTED TO _____ FOR: Reference Approval Construction
SUBMITTED BY _____ DATE _____

UNIT DESIGNATION: Schedule No. _____ MODEL NO. _____

PRODUCT DATA

COOLING PERFORMANCE

TOTAL CAPACITY MBH
OUTDOOR DESIGN TEMP. °F
SUCT. PRESS. AT SATURATION PSIG
SUCT. TEMP. AT SATURATION. °F

ELECTRICAL DATA

POWER SUPPLY
TOTAL UNIT AMPACITY AMPS
POWER INPUT REQUIREMENT KW
MINIMUM WIRE SIZE AWG
(Copper Conductors)
MAXIMUM FUSE SIZE AMPS
(Dual Element)

UNIT WEIGHT

TOTAL OPERATING WEIGHT LBS.

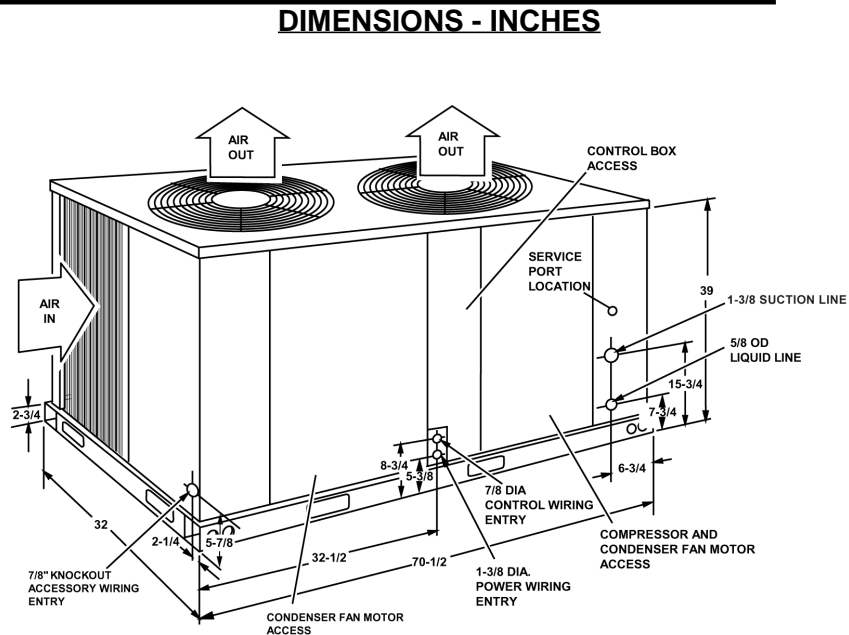

FEATURES:

- UL and CSA Approval
- Weatherized Casing with powder paint (750 hour salt spray hours)
- Propeller-Type Outdoor Air Fan
- Inherently Protected Fan Motor
- Factory Wiring
- Refrigerant-22 Holding Charge
- Anti-Recycle Protection
- 24 Volt Temperature Control Circuit
- Copper Tube/Aluminum Fin Coil
- High, Low & Oil Pressure Controls
- Back Seating Suction & Liquid Line Service Valves
- Factory-mounted expansion valve and filter-drier in heating circuit
- Permanently attached base rails with forklift slots and lifting holes. This design allows for 3-way forklift access and overhead rigging.
- Separate panel for easy access to the control box without affecting air flow across the outdoor coil.
- Gauge line refrigerant fittings external to unit.
- Filter Drier
- 5-Year Limited Warranty on Compressor; 1-Year Limited Parts Warranty on all Other Parts

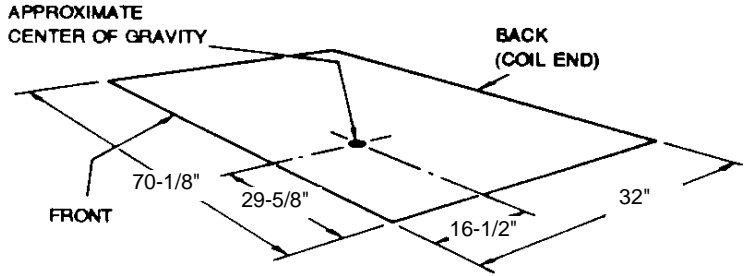

CLEARANCES

Overhead (Top) ¹	120 in.
Front (Piping & Access Panels)	30 in.
Left Side	24 in.
Right Side	24 in.
Rear	24 in.
Bottom ²	0 in.

¹Units must be installed outdoors. Overhanging structures or shrubs should not obstruct condenser air discharge.
²Adequate snow clearance must be provided if winter operation is expected.

FIELD INSTALLED ACCESSORIES:

- 0° Low Ambient Controls . . . ()
Coil Guard ()

MATCHING AIR SIDE EQUIPMENT:

- Model No. ()
Submittal Form No. ()

NOTES: _____

SPLIT-SYSTEM HEAT PUMP UNITS
MODELS EF-07
7 1/2 TONS

036-22230-001-A-0902

Supersedes: Nothing

