

SUBMITTAL DATA SHEET



ECHELON SPLIT SYSTEM HEAT PUMP UNITS
R-22 - 13 SEER 1-1/2, 2, 2-1/2, 3, 3-1/2, 4 & 5 TON
MODELS: HC3A018 THRU 060

JOB NAME:			LOCATION:		
PURCHASER:			ORDER NO.:		
ENGINEER:					
SUBMITTED TO:	FOR:	REF:	APPROVAL:	CONSTRUCTION:	
SUBMITTED BY:			DATE:		
UNIT DESIGNATION:			SCHEDULE NO.	MODEL NO.	

PRODUCT DATA

Cooling Performance

Total Capacity _____ MBH

Outdoor Design Temp _____ °F

Electrical Data

Power Supply _____ / _____ / _____

Total Unit Ampacity _____ AMPs

Power Input Req _____ KW

Minimum Wire Size _____ AWG

Maximum Overcurrent Device

Fuses Circuit Breaker

Unit Weight

Unit Weight _____ LBS

DIMENSIONS - INCHES

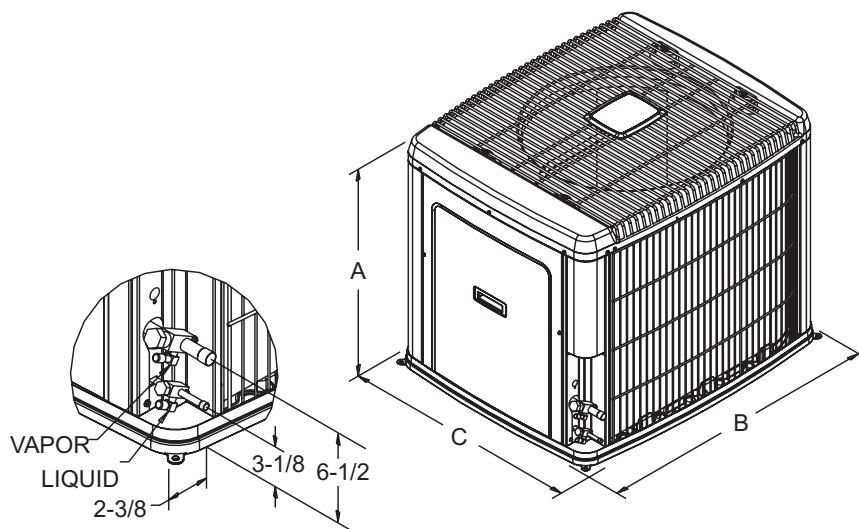

All dimensions are in inches. They are subject to change without notice. Certified dimensions will be provided upon request.

Unit Model	Dimensions (Inches)			Refrigerant Connection Service Valve Size	
	A	B	C	Liquid	Vapor
018	29-1/2	37	31	3/8"	3/4"
024	33-1/2	37	31		
030	39-1/2	37	31		
036	39-1/2	42	34		7/8"
042	39-1/2	42	34		
048	39-1/2	42	34		
060	39-1/2	42	34		

* Expander fitting required for 1-1/8" lineset.



CERTIFICATION APPLIES ONLY WHEN THE COMPLETE SYSTEM IS LISTED WITH ARI.

FEATURES

- UL approval (units & accessories)
- CSA listed and ARI certified
- 5-year limited parts warranty
- 10-year limited warranty on the compressor
- Copper tube/aluminum fin coil
- Hi and Lo pressure switches standard
- Durable construction
- Powder-painted steel cabinet
- Factory wired
- R-22 total system charge (thru 15 ft. of lines)
- Sweat refrigerant connections
- Re-usable service valves
- Slide down electrical compartment for easy access
- Enhanced coil guard
- Composite base pan
- Isolated compressor compartment
- Full service access panel

MATCHING AIR SIDE EQUIPMENT

Model No. ()
 Submittal Form No. ()

FIELD INSTALLED ACCESSORIES

Dehumidification Control (2HU16700124)()
 Thermostat ()
 Thermal Expansion Valve* ()
 Hard Start Kit ()
 Compressor Discharge Temperature Sensor Kit ()
 Bonnet Sensor kit ()
 Heat Pump Risers ()
 Two Speed Fan Control- Furnaces ()
 Two Speed Fan Control - Air Handlers ()

* Must be installed for proper performance.

CLEARANCES

Front of Unit24 inch
 All Other Sides 12 inch
 Above Unit60 inch
 Below Unit..... 0 inch

*Must be installed for proper

NOTES:
