

TECHNICAL GUIDE

ADD - ON COILS FOR USE WITH SPLIT-SYSTEM COOLING & HEAT PUMPS MODELS: GHD, GFD, GFA, GNA, GUA & GHA 600 - 2000 CFM 2 - 5 TON COILS



HORIZONTAL
G1HD



FULL CASED
MULTI-POSITION
G2FD



UPFLOW UNCASED
G1NA



UPFLOW CASED
G1FA



HORIZONTAL CASED
G1HA



UPFLOW
G1UA



Due to continuous product improvement, specifications are subject to change without notice.

Visit us on the web at www.york.com for the most up-to-date technical information.

Additional rating information can be found at www.ariprimenet.org.

DESCRIPTION

These cooling and heat pump coils are designed to be installed with UPG furnaces and to be matched with UPG cooling and heat pump outdoor units. All coils are available as sweat-connect models for your convenience and ease of matching.

Upflow Coils - Available in high-capacity models to match any system and upflow furnace. Models available with factory installed TXV or orifice metering system.

Multi-Position Coils - Available in high-capacity models to match any system and any multi-position furnace and air handler. Selected models available with factory installed TXV or standard orifice metering systems. Selected models also available from the factory with thicker 3/4" cabinet insulation.

Horizontal Duct Coils - Available to match any cooling or heat pump system and horizontal furnace. Field transition may be required.

Dedicated Horizontal Cased Coils - Available to match most cooling or heat pump systems and any horizontal gas furnace or modular air handler. For horizontal application only. Models available with factory installed TXV or orifice metering system.

FEATURES

Insulated Cabinet - All evaporator coil cabinets are thermally insulated to prevent sweating.

Internally Clean - All evaporator coils are factory leak-tested, dehydrated, sealed and shipped with a holding charge.

Durable Finish - Coil casings are made of pre-painted steel. The pre-treated flat galvanized steel provides a better paint to steel bond, which resists corrosion and rust creep.

Optimum Heat Transfer - Using the latest in heat transfer technology, staggered rows of rifled copper tubes are mechanically expanded into aluminum fins to provide optimum air to surface contact for ample moisture removal as well as high performance ratings.

Optional Factory Installed Thermal Expansion Valve - Provides flexibility to match high efficiency applications at a lower installed cost.

ACCESSORIES

Refer to Price Manual for specific model numbers.

TXV Kits - Thermal expansion valve kits are available for indoor coils to obtain specific system performance.

Horizontal Drain Pan Kits - A field installed horizontal drain pan kit (1HP0623BK or 1HP0628BK) is available for horizontal applications on the multi-position coil. The full cased multi-position coil is also available with a factory installed horizontal drain pan option.

COOLING CAPACITY - Coil Only*

Model	Rated CFM	Entering Air °F (Wet Bulb)	MBH @ Evaporator Temperature and Corresponding Pressure °F / PSIG			
			35 / 61.5	40 / 68.5	45 / 76.0	50 / 84.0
UPFLOW "A" TYPE						
G1FA024S14(T) G1UA024S14	675	72	35.6	32.5	29.0	25.2
		67	32.9	29.7	26.3	22.7
		62	27.0	23.9	20.7	17.4
		57	21.9	19.0	15.9	12.4
G1FA024S17(T) G1UA024S17	850	72	35.6	32.5	29.0	25.2
		67	32.9	29.7	26.3	22.7
		62	27.0	23.9	20.7	17.4
		57	21.9	19.0	15.9	12.4
G1FA030S14(T) G1UA030S14	1025	72	38.9	35.4	31.6	27.6
		67	33.9	30.3	26.8	23.0
		62	27.3	23.7	22.5	18.0
		57	22.6	20.1	17.5	14.8
G1FA036S14(T) G1FA036S17(T) G1UA036S14 G1UA036S17	1250	72	51.1	46.5	41.5	36.6
		67	40.9	36.1	31.7	26.9
		62	32.0	26.8	29.3	21.8
		57	27.4	25.4	23.4	21.8
G1FA036S21(T) G1UA036S21	1250	72	51.1	46.5	41.5	36.6
		67	40.9	36.1	31.7	26.9
		62	32.0	26.8	29.3	21.8
		57	27.4	25.4	23.4	21.8
G1FA048S17(T) G1FA048S21(T) G1UA048S17 G1FA048S21	1620	72	99.4	85.5	71.2	56.2
		67	79.6	66.8	54.4	41.6
		62	62.1	49.4	40.2	33.7
		57	53.3	46.7	40.2	33.7
G1FA060S21(T) G1FA060S24(T) G1UA060S21 G1UA060S24	1850	72	118.7	100.0	81.1	61.5
		67	95.0	78.4	61.9	45.4
		62	74.0	58.0	45.7	36.7
		57	63.6	54.8	45.7	36.7

* - See Condensing Unit or Heat Pump Technical Guide for Total Cooling Capacity and Sensible Capacity.
(T) indicates models with factory installed thermal expansion valve.

Coil Only*

MODEL	RATED CFM	ENTERING AIR °F (Wet Bulb)	MBH @ Evaporator Temperature and Corresponding Pressure °F / PSIG			
			35 / 61.5	40 / 68.5	45 / 76.0	50 / 84.0
HORIZONTAL DUCT TYPE						
G1HD024	815	72	35.3	32.4	28.7	24.9
		67	32.6	29.4	26.0	22.5
		62	26.7	23.7	20.5	17.2
		57	21.7	18.8	15.7	12.3
G1HD036	1192	72	57.9	52.7	47.1	41.5
		67	46.4	41.1	35.9	30.4
		62	36.2	30.4	26.5	24.7
		57	31.1	28.7	26.5	24.7
G1HD048	1610	72	83.4	71.7	59.7	47.1
		67	66.8	56.1	45.6	34.9
		62	52.1	41.5	33.7	28.3
		57	44.7	39.2	33.7	28.3
G1HD060	2100	72	133.0	112.4	90.9	69.2
		67	106.5	87.9	69.4	50.0
		62	83.0	65.0	51.3	41.1
		57	71.2	61.4	51.3	41.1

* See Condensing Unit or Heat Pump Technical Guide for Total Cooling Capacity and Sensible Capacity.

COOLING CAPACITY - COIL ONLY*

Model Coil	Rated CFM	Entering Air °F (Wet Bulb)	MBH@ Evaporator Temperature and Corresponding Pressure °F / PSIG			
			35 / 61.5	40 / 68.5	45 / 76.0	50 / 84.0
FULL-CASED "A" TYPE MULTI-POSITION						
G2FD024(S,H)14(T) G2FD024(S,H)17(T)(X)	850	72	36.3	33.0	29.5	25.6
		67	33.4	30.2	26.7	23.1
		62	27.4	24.3	21.0	17.7
		57	22.2	19.3	16.2	12.6
G2FD030(S,H)17(T) G2FD035(S,H)14(T)	1025	72	41.5	37.8	33.7	29.5
		67	36.2	32.4	28.6	24.5
		62	29.1	25.3	24.0	19.2
		57	24.1	21.5	18.7	15.8
G2FD036(S,H)17(T)(X)	1250	72	52.0	47.3	42.3	37.3
		67	41.7	36.8	32.3	27.4
		62	32.5	27.3	29.8	22.2
		57	27.9	25.8	23.8	22.2
G2FD036(S,H)21(T)	1200	72	53.4	48.6	43.4	38.3
		67	42.8	37.8	33.1	28.2
		62	33.4	28.1	30.6	22.8
		57	28.7	26.5	24.5	22.8
G2FD046(S,H)17(T)(X) G2FD042(S,H)21(T)	1400	72	88.4	76.0	63.3	50.0
		67	70.8	59.4	48.4	37.0
		62	55.2	43.9	35.8	29.9
		57	47.4	41.5	35.8	29.9
G2FD048(S,H)21(T)(X) G2FD048(S,H)24(T)	1650	72	100.5	86.4	72.0	56.8
		67	80.4	67.5	55.0	42.1
		62	62.7	49.9	40.7	34.0
		57	53.9	47.2	40.7	34.0
G2FD060(S,H)24(T)(X)	1825	72	119.9	101.0	80.0	62.2
		67	96.0	79.2	62.6	45.8
		62	74.8	58.6	46.2	37.0
		57	64.3	55.4	46.2	37.0
G2FD061H24(T)(X)	2000	72	124.8	105.2	85.3	64.7
		67	99.9	82.5	65.2	47.7
		62	77.9	61.1	48.1	38.6
		57	66.9	57.7	48.1	38.6

* See Condensing Unit or Heat Pump Technical Guide for Total Cooling Capacity and Sensible Capacity.

Notes:

- G2FD coils available with a factory installed horizontal drain pan option (H).
- G2FD061H24 is only available with a factory mounted horizontal pan.

(T) = Indicates models with factory installed thermal expansion valve. Only available on coils with factory installed horizontal drain pan (H).

(X) = Models shown with X suffix are available with increased cabinet insulation thickness. Only available on coils without factory installed horizontal drain pan (S) except 061.

COOLING CAPACITY - COIL ONLY*

Model	Rated CFM	Entering Air °F (Wet Bulb)	MBH @ EVAPORATOR TEMPERATURE AND CORRESPONDING PRESSURE °F / PSIG			
			35/61.5	40/68.5	45/76.0	50/84.0
G1HA024H14(T)	800	72	35.2	32.0	28.6	24.8
		67	32.4	29.3	25.9	22.4
		62	26.6	23.6	20.4	17.2
		57	21.5	18.7	15.7	12.2
G1HA036H14(T)	1150	72	49.1	44.7	39.9	35.2
		67	39.4	34.8	30.5	25.9
		62	30.7	25.9	28.2	22.8
		57	26.4	24.4	22.5	21.0
G1HA036H17(T)	1200	72	73.4	63.1	52.5	41.5
		67	58.8	49.3	40.2	30.7
		62	45.8	36.4	29.7	24.8
		57	39.3	34.4	28.1	23.2
G1HA048H21(T)	1550	72	94.4	81.2	67.6	53.4
		67	75.6	65.4	51.7	39.5
		62	59.0	46.9	38.2	32.0
		57	50.6	44.4	35.6	29.7
G1HA060H24(T)	1800	72	112.8	95.0	77.0	58.4
		67	90.3	74.5	58.8	43.1
		62	70.3	55.1	43.4	34.9
		57	60.4	52.1	40.4	31.9

* See Condensing Unit or Heat Pump Technical Guide for Total Cooling Capacity and Sensible Capacity.

(T) indicates models with factory installed thermal expansion valve.

COOLING CAPACITY - COIL ONLY*

Model Coil	Rated CFM	Entering Air °F (Wet Bulb)	MBH@ Evaporator Temperature and Corresponding Pressure °F / PSIG			
			35 / 61.5	40 / 68.5	45 / 76.0	50 / 84.0
uncased upflow						
G1NA024S17G	800	72	27.4	25.0	22.3	19.4
		67	25.3	22.9	20.3	17.5
		62	20.8	18.4	15.9	13.4
		57	16.9	14.6	12.2	9.4
G1NA030S17H	1000	72	35.2	32.0	28.6	24.8
		67	32.4	28.6	25.3	21.9
		62	26.6	23.6	21.5	18.7
		57	25.2	22.7	20.2	17.6
G1NA030S17K	1000	72	39.6	36.0	32.1	27.9
		67	36.4	33.2	29.5	25.7
		62	29.9	27.2	24.2	21.0
		57	28.1	25.6	22.7	19.8
G1NA036S17J	1200	72	49.3	44.9	39.9	34.7
		67	45.4	41.3	36.7	32.0
		62	37.2	33.8	30.1	26.2
		57	35.0	28.3	28.3	24.6
G1NA036S17L	1200	72	59.9	54.5	48.5	42.6
		67	55.1	51.1	44.6	38.9
		62	45.2	41.1	36.6	31.9
		57	42.5	38.7	34.4	30.0
G1NA036S21C	1200	72	49.3	44.9	39.9	34.7
		67	45.4	41.3	36.7	32.0
		62	37.2	33.8	30.1	26.2
		57	35.0	31.8	28.3	24.6
G1NA042S24W	1400	72	86.7	73.0	59.2	44.9
		67	69.4	57.2	45.2	33.1
		62	54.0	42.3	33.4	26.8
		57	46.4	40.0	33.4	26.8
G1NA048S21D	1400	72	62.4	56.8	50.5	44.4
		67	57.4	53.2	46.5	40.5
		62	47.1	42.8	38.1	33.2
		57	44.3	40.3	35.8	31.2
G1NA060S24T	1800	72	95.4	82.1	68.4	54.0
		67	76.4	64.1	52.2	39.9
		62	59.6	47.4	38.6	32.4
		57	51.2	44.8	38.6	32.4

* See Condensing Unit or Heat Pump Technical Guide for Total Cooling Capacity and Sensible Capacity.

APPLICATION FACTOR-RATED CFM VS. ACTUAL CFM

% OF RATED AIR FLOW	80%	90%	RATED CFM	110%	120%
CAPACITY FACTOR	0.96	0.98	1.00	1.02	1.03

NOTE: Do not exceed minimum/maximum CFM limits shown under Air Flow Data.

APPLICATION LIMITATIONS

These units must be installed in accordance with all national and local safety codes.

Air flow must be within the minimum and maximum limits approved for electric heat, evaporator coils and outdoor units.

Entering Air Temperature Limits			
Wet Bulb Temp. °F		Dry Bulb Temp. °F	
Min.	Max.	Min.	Max.
57	72	65	95

STATIC PRESSURE VS. AIRFLOW (BASED ON WET COIL)

Model	Airflow	Wet Coil	
UPFLOW CASED "A" TYPE			
G1FA024S14(T) G1UA024S14	600	0.12	
	800	0.21	
	1000	0.33	
G1FA024S17(T) G1UA024S17	600	0.10	
	800	0.17	
	1000	0.27	
G1FA030S14(T) G1UA030S14	800	0.14	
	1000	0.22	
	1200	0.31	
G1FA036S14(T) G1UA036S14	1000	0.21	
	1200	0.30	
	1400	0.40	
G1FA036S17(T) G1UA036S17	1000	0.18	
	1200	0.26	
	1400	0.36	
G1FA036S21(T) G1UA036S21	1000	0.15	
	1200	0.22	
	1400	0.30	
G1FA048S17(T) G1UA048S17	1200	0.19	
	1400	0.25	
	1600	0.33	
G1FA048S21(T) G1UA048S21	1800	0.42	
	1200	0.16	
	1400	0.22	
G1FA048S21(T) G1UA048S21	1600	0.28	
	1800	0.36	
	1600	0.25	
G1FA060S21(T) G1UA060S21	1800	0.32	
	2000	0.39	
	2200	0.47	
G1FA060S24(T) G1UA060S24	1600	0.22	
	1800	0.28	
	2000	0.35	
G1FA060S24(T) G1UA060S24	2200	0.42	
	HORIZONTAL-DUCT TYPE		
	G1HD024	600	0.06
800		0.10	
1000		0.16	
G1HD036	1000	0.19	
	1200	0.28	
	1400	0.38	
G1HD048	1200	0.14	
	1400	0.19	
	1600	0.25	
G1HD060	1800	0.32	
	1600	0.16	
	1800	0.20	
G1HD060	2000	0.25	
	2200	0.30	
	HORIZONTAL CASED		
G1HA024H14 (T)	600	0.07	
	800	0.12	
	1000	0.19	
G1HA036H14 (T)	800	0.21	
	900	0.25	
	1150	0.30	
G1HA036H17 (T)	1200	0.31	
	1000	0.20	
	1100	0.24	
G1HA036H17 (T)	1200	0.27	
	1300	0.30	
	1400	0.25	
G1HA048H21 (T)	1500	0.28	
	1550	0.30	
	1600	0.33	
G1HA060H24 (T)	1700	0.25	
	1800	0.28	
	1850	0.30	
G1HA060H24 (T)	1900	0.31	
	2000	0.34	

(T) Indicates models with factory installed thermal expansion valve.

Model	Airflow	Wet Coil	
CASED "A" TYPE MULTI-POSITION			
G2FD024(S,H)14(T)	600	0.10	
	800	0.19	
	1000	0.29	
G2FD024(S,H)17(T)	600	0.08	
	800	0.15	
	1000	0.23	
G2FD035(S,H)14(T)	800	0.22	
	1000	0.34	
	1200	0.49	
G2FD030(S,H)17(T)	800	0.18	
	1000	0.28	
	1200	0.40	
G2FD036(S,H)17(T)(X)	1000	0.17	
	1200	0.24	
	1400	0.33	
G2FD036(S,H)21(T)	1000	0.23	
	1200	0.33	
	1400	0.45	
G2FD046(S,H)17(T)(X)	1000	0.15	
	1200	0.22	
	1400	0.30	
G2FD042(S,H)21(T)	1200	0.22	
	1400	0.30	
	1600	0.40	
G2FD048(S,H)21(T)(X)	1200	0.17	
	1400	0.24	
	1600	0.31	
G2FD048(S,H)24(T)	1800	0.39	
	1200	0.15	
	1400	0.21	
G2FD048(S,H)24(T)	1600	0.27	
	1800	0.34	
	1600	0.22	
G2FD060(S,H)24(T)(X)	1800	0.28	
	2000	0.34	
	2200	0.41	
G2FD061H24	1600	0.18	
	1800	0.23	
	2000	0.28	
G2FD061H24	2200	0.34	
	UNCASED UPFLOW		
	G1NA024S17G	600	0.11
800		0.20	
1000		0.31	
G1NA030S17H	800	0.17	
	1000	0.27	
	1200	0.38	
G1NA030S17K	800	0.16	
	1000	0.25	
	1200	0.36	
G1NA036S17J	1000	0.21	
	1200	0.31	
	1400	0.42	
G1NA036S17L	1000	0.22	
	1200	0.30	
	1400	0.38	
G1NA036S21C	1000	0.18	
	1200	0.24	
	1400	0.29	
G1NA042S24W	1200	0.29	
	1400	0.39	
	1600	0.51	
G1NA048S21D	1200	0.28	
	1400	0.38	
	1600	0.50	
G1NA048S21D	1800	0.63	
	1600	0.25	
	1800	0.32	
G1NA060S24T	2000	0.39	
	2200	0.47	

(T) Indicates models with factory installed thermal expansion valve.

PHYSICAL DATA

Model	Application	Refrig. Conn. Types	Std. Orifice Size	Face Area (Sq. Ft.)	Rows Deep	Fin Per In.	Coil Size	Tube Geometry	Tube Dia.	Fin Type	Expansion Device	Operating Weight (Lbs.)						
UPFLOW "A" TYPE																		
G1FA024S14	Cooling / Heat Pump	Sweat	59	2.92	2	14	(2) 12 x 17.5	1 x 0.866	3/8	Enhanced	Orifice	30						
G1FA024S14T			--	2.92	2	14	(2) 12 x 17.5				2 Ton TXV	32						
G1FA024S17			59	2.92	2	14	(2) 12 x 17.5				Orifice	31						
G1FA024S17T			--	2.92	2	14	(2) 12 x 17.5				2 Ton TXV	33						
G1FA030S14			65	3.40	2	14	(2) 12 x 17.5				Orifice	38						
G1FA030S14T			--	3.40	2	14	(2) 12 x 17.5				2 Ton TXV	40						
G1FA036S14			73	4.38	2	14	(2) 18 x 17.5				Orifice	41						
G1FA036S14T			--	4.38	2	14	(2) 18 x 17.5				3 Ton TXV	43						
G1FA036S17			73	3.89	2	14	(2) 16 x 17.5				Orifice	40						
G1FA036S17T			--	3.89	2	14	(2) 16 x 17.5				3 Ton TXV	42						
G1FA036S21			73	3.89	2	14	(2) 16 x 17.5				Orifice	45						
G1FA036S21T			--	3.89	2	14	(2) 16 x 17.5				3 Ton TXV	47						
G1FA048S17			84	5.83	2	11	(2) 24 x 17.5				Orifice	64						
G1FA048S17T			--	5.83	2	11	(2) 24 x 17.5				5 Ton TXV	66						
G1FA048S21			84	4.86	3	11	(2) 20 x 17.5				Orifice	64						
G1FA048S21T			--	4.86	3	11	(2) 20 x 17.5				5 Ton TXV	66						
G1FA060S21			90	5.83	3	12	(2) 24 x 17.5				Orifice	75						
G1FA060S21T			--	5.83	3	12	(2) 24 x 17.5				5 Ton TXV	77						
G1FA060S24			90	5.83	3	12	(2) 24 x 17.5				Orifice	78						
G1FA060S24T			--	5.83	3	12	(2) 24 x 17.5				5 Ton TXV	80						
G1UA024S14	Cooling / Heat Pump	Sweat	59	2.92	2	14	(2) 12 x 17.5	1 x 0.866	3/8	Enhanced	Orifice	30						
G1UA024S17			59	2.92	2	14	(2) 12 x 17.5					31						
G1UA030S14			65	3.40	2	14	(2) 12 x 17.5					38						
G1UA036S14			73	4.38	2	14	(2) 18 x 17.5					41						
G1UA036S17			73	3.89	2	14	(2) 16 x 17.5					40						
G1UA036S21			73	3.89	2	14	(2) 16 x 17.5					45						
G1UA048S17			84	5.83	2	11	(2) 24 x 17.5					64						
G1UA048S21			84	4.86	3	11	(2) 20 x 17.5					64						
G1UA060S21			90	5.83	3	12	(2) 24 x 17.5					75						
G1UA060S24			90	5.83	3	12	(2) 24 x 17.5					78						
HORIZONTAL - DUCT TYPE																		
G1HD024			Cooling / Heat Pump	Sweat	59	3.67	2					14	22 x 24	1 x 0.866	3/8	Enhanced	Orifice	34
G1HD036	69	3.67			3	11	22 x 24	40										
G1HD048	81	4.33			3	12	26 x 24	46										
G1HD060	93	5.42			3	11	26 x 30	52										
UNCASED UPFLOW																		
G1NA024S17G	Cooling / Heat Pump	Sweat	51	2.75	2	16	12 x 16.5	1 x 0.625	5/16	High Efficiency	Orifice	20						
G1NA030S17H			57	3.21	3	14	14 x 16.5					26						
G1NA030S17K			63	3.67	3	14	16 x 16.5					29						
G1NA036S17J			67	4.13	3	14	18 x 16.5					31						
G1NA036S17L			71	4.13	4	12	18 x 16.5					36						
G1NA036S21C			67	4.13	3	14	18 x 16.5					32						
G1NA048S21D			78	4.13	4	12	18 x 16.5	39										
G1NA042S24W			84	5.26	4	12	22 x 17.5	1 x 0.866	3/8	Enhanced		54						
G1NA060S24T			87	5.73	4	12	24 x 17.5	1 x 0.625	5/16	High Efficiency		48						

PHYSICAL DATA (Continued)

Model	Application	Refrig. Conn. Types	Std. Orifice Size	Face Area (Sq. Ft.)	Rows Deep	Fin Per In.	Coil Size	Tube Geometry	Tube Dia.	Fin Type	Expansion Device	Operating Weight (Lbs.)
FULL CASED "A" TYPE MULTI-POSITION												
G2FD024(S,H)14	Cooling / Heat Pump	Sweat	61	3.40	2	14	(2) 14 x 17.5	1 x 0.866	3/8	Enhanced	Orifice	37
G2FD024H14T			--	3.40	2	14	(2) 14 x 17.5				2 Ton TXV	39
G2FD024(S,H)17			61	3.40	2	14	(2) 14 x 17.5				Orifice	42
G2FD024H17T			--	3.40	2	14	(2) 14 x 17.5				2 Ton TXV	44
G2FD030(S,H)17			65	3.88	2	14	(2) 16 x 17.5				Orifice	48
G2FD030H17T			--	3.88	2	14	(2) 16 x 17.5				2 Ton TXV	50
G2FD035(S,H)14			65	3.89	2	14	(2) 16 x 17.5				Orifice	46
G2FD035H14T			--	3.89	2	14	(2) 16 x 17.5				2 Ton TXV	48
G2FD036(S,H)17			75	4.86	2	14	(2) 20 x 17.5				Orifice	55
G2FD036H17T			--	4.86	2	14	(2) 20 x 17.5				3 Ton TXV	57
G2FD036(S,H)21			75	3.40	3	12	(2) 14 x 17.5				Orifice	58
G2FD036H21T			--	3.40	3	12	(2) 14 x 17.5				3 Ton TXV	60
G2FD042(S,H)21			78	4.86	3	11	(2) 16 x 17.5				Orifice	62
G2FD042H21T			--	4.86	3	11	(2) 16 x 17.5				3 Ton TXV	64
G2FD046(S,H)17			78	5.83	2	14	(2) 24 x 17.5				Orifice	65
G2FD046H17T			--	5.83	2	14	(2) 24 x 17.5				5 Ton TXV	67
G2FD048(S,H)21			84	5.35	3	12	(2) 22 x 17.5				Orifice	69
G2FD048H21T			--	5.35	3	12	(2) 22 x 17.5				5 Ton TXV	71
G2FD048(S,H)24			84	5.35	3	12	(2) 22 x 17.5				Orifice	71
G2FD048H24T			--	5.35	3	12	(2) 2 x 17.5				5 Ton TXV	73
G2FD060(S,H)24	90	5.83	3	12	(2) 24 x 17.5	Orifice	79					
G2FD060H24T	--	5.83	3	12	(2) 24 x 17.5	5 Ton TXV	81					
G2FD061H24	90	6.81	3	12	(2) 28 x 17.5	Orifice	89					

Note:

- G2FD coils available with a factory installed horizontal drain pan option (H).
- G2FD061H24 is only available with a factory mounted horizontal pan.
- Data applies to G2FD models with or without (X).

HORIZONTAL CASED TYPE

G1HA024H14	Cooling / Heat Pump	Sweat	61	3.40	2	14	(2) 14 x 17.5	1 x 0.866	3/8	Enhanced	Orifice	38
G1HA024H14(T)			--	3.40	2	14	(2) 14 x 17.5				2 Ton TXV	40
G1HA036H14			75	3.40	3	12	(2) 14 x 17.5				Orifice	47
G1HA036H14(T)			--	3.40	3	12	(2) 14 x 17.5				3 Ton TXV	49
G1HA036H17			78	4.86	3	11	(2) 16 x 17.5				Orifice	52
G1HA036H17(T)			--	4.86	3	11	(2) 16 x 17.5				3 Ton TXV	54
G1HA048H21			84	4.86	3	11	(2) 20 x 17.5				Orifice	64
G1HA048H21(T)			--	4.86	3	11	(2) 20 x 17.5				5 Ton TXV	66
G1HA060H24			90	5.83	3	12	(2) 24 x 17.5				Orifice	74
G1HA060H24(T)			--	5.83	3	12	(2) 24 x 17.5				5 Ton TXV	76

Note:

- G1HA Models with the (T) option feature a factory installed thermal expansion valve.

DIMENSIONS
G1FA UPFLOW CASED COIL

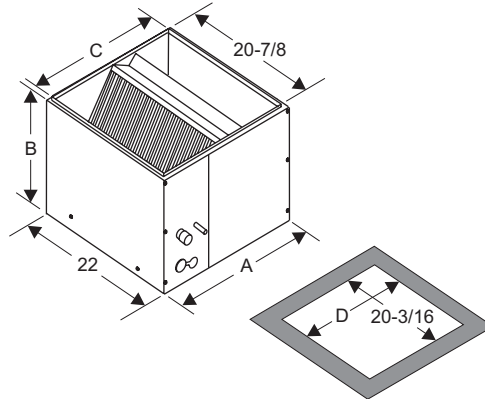

Model	Dimensions — Inches							Refrigerant Connections	
	A	B	C	D	E	F	G	Line Size	
								Liquid	Vapor
G1FA024S14(T)	14-1/2	16	13-3/8	13-1/2	-	-	-	3/8	5/8
G1FA024S17(T)	17-1/2	16	16-3/8	16-1/2	-	-	-	3/8	5/8
G1FA030S14(T)	14-1/2	18	13-3/8	13-1/2	-	-	-	3/8	3/4
G1FA036S14(T)	14-1/2	22-1/4	13-3/8	13-1/2	-	-	-	3/8	3/4
G1FA036S17(T)	17-1/2	19-1/2	16-3/8	16-1/2	-	-	-	3/8	3/4
G1FA036S21(T)	21	19-1/2	19-7/8	20	-	-	-	3/8	3/4
G1FA048S17(T)	17-1/2	28-1/4	16-3/8	16-1/2	-	-	-	3/8	7/8
G1FA048S21(T)(T)	21	24	19-7/8	20	-	-	-	3/8	7/8
G1FA060S21(T)	21	28-1/4	19-7/8	20	-	-	-	3/8	7/8
G1FA060S24(T)	24-1/2	28-1/4	23-3/8	23-1/2	-	-	-	3/8	7/8

NOTE: (T) indicates models with factory installed thermal expansion valve.

G1UA UPFLOW CASED COIL

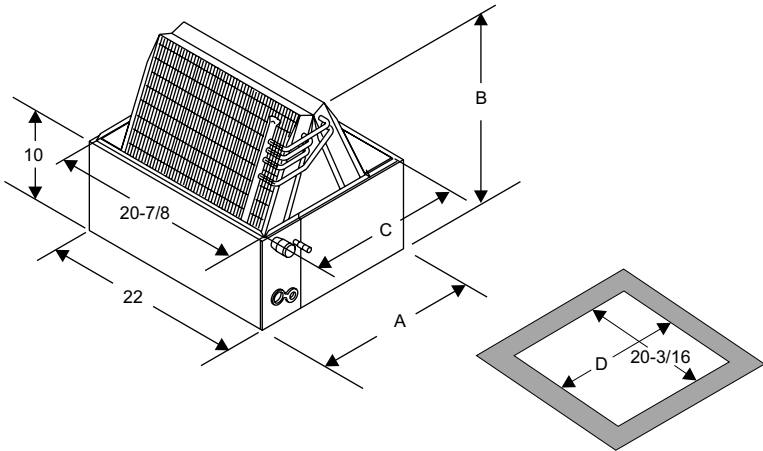

Model	Dimensions — Inches							Refrigerant Connections	
	A	B	C	D	E	F	G	Line Size	
								Liquid	Vapor
G1UA024S14	14-1/2	14-1/2	13-3/8	13-1/2	-	-	-	3/8	5/8
G1UA024S17	17-1/2	14	16-3/8	16-1/2	-	-	-	3/8	5/8
G1UA030S14	14-1/2	16-5/8	13-3/8	13-1/2	-	-	-	3/8	3/4
G1UA036S14	14-1/2	19-7/8	13-3/8	13-1/2	-	-	-	3/8	3/4
G1UA036S17	17-1/2	18-3/8	16-3/8	16-1/2	-	-	-	3/8	3/4
G1UA036S21	21	17-7/8	19-7/8	20	-	-	-	3/8	3/4
G1UA048S17	17-1/2	25-5/8	16-3/8	16-1/2	-	-	-	3/8	7/8
G1UA048S21	21	22-5/8	19-7/8	20	-	-	-	3/8	7/8
G1UA060S21	21	26-3/8	19-7/8	20	-	-	-	3/8	7/8
G1UA060S24	24-1/2	26-1/8	23-3/8	23-1/2	-	-	-	3/8	7/8

G1HD HORIZONTAL DUCT COIL

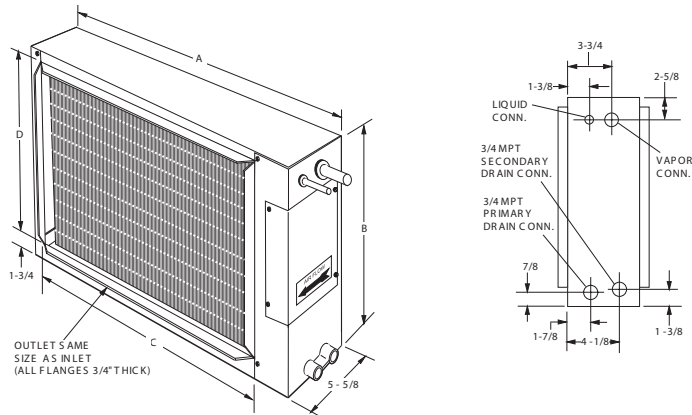

Model	Dimensions — Inches							Refrigerant Connections	
	A	B	C	D	E	F	G	Line Size	
								Liquid	Vapor
G1HD024	28-3/4	24	23-3/4	21-5/8	-	-	-	3/8	5/8
G1HD036	28-3/4	24	23-3/4	21-5/8	-	-	-	3/8	3/4
G1HD048	28-3/4	28	23-3/4	25-5/8	-	-	-	3/8	7/8
G1HD060	34-3/4	28	29-3/4	25-5/8	-	-	-	3/8	7/8

G1Ha HORIZONTAL

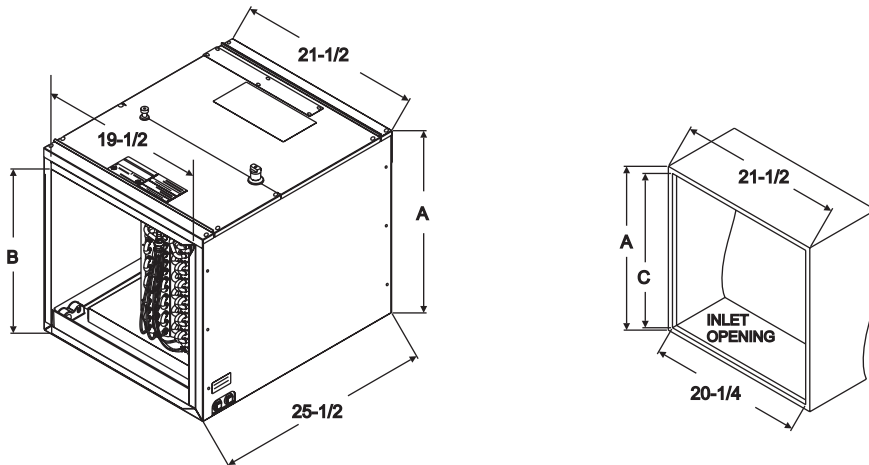

Model	Dimensions — Inches			Refrigerant Connections	
	A	B	C	Line Size	
				Liquid	Vapor
G1HA024S14(T)	15-5/16	13-1/4	14-3/16	3/8	3/4
G1HA036S14(T)					
G1HA036S17(T)	17-9/16	15-1/2	16-7/16		3/4
G1HA048S21(T)	21-5/16	19-1/4	20-3/16		7/8
G1HA060S24(T)	25-5/16	23-1/4	24-3/16		7/8

NOTE: (T) indicates models with factory installed thermal expansion valve.

G2FD MULTI-POSITION “A” COIL

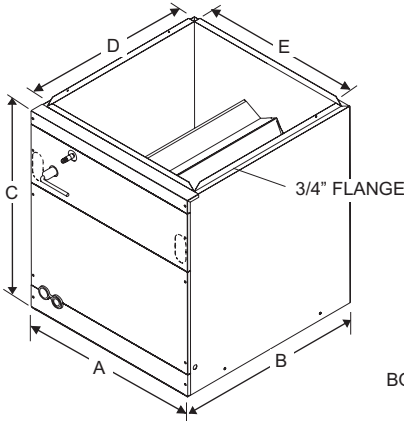

(Available with or without a factory installed horizontal drain pan).

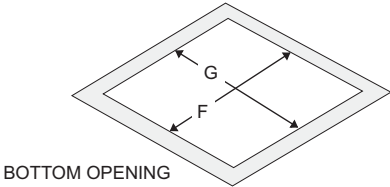

Model	Dimensions — Inches							Refrigerant Connections			
	A	B	C	D	E	F	G	Quick-Connect		Line Size	
								Liquid	Vapor	Liquid	Vapor
G2FD024(S,H)14(T)	14-1/2	22	23	19-7/8	13-3/8	20-3/16	13-1/2	—	—	3/8	5/8
G2FD024(S,H)17(T)(X)	17-1/2		23		16-3/8		16-1/2	5/8			
G2FD035(S,H)14(T)	14-1/2		23		13-3/8		13-1/2	5/8			
G2FD030(S,H)17(T)	17-1/2		23		16-3/8		16-1/2	5/8			
G2FD036(S,H)17(T)(X)	17-1/2		28		16-3/8		16-1/2	3/4			
G2FD036(S,H)21(T)	21		23		19-7/8		20	3/4			
G2FD046(S,H)17(T)(X)	17-1/2		28		16-3/8		16-1/2	7/8			
G2FD042(S,H)21(T)	21		23		19-7/8		20	7/8			
G2FD048(S,H)21(T)(X)	21		28		19-7/8-		20	7/8			
G2FD048(S,H)24(T)	24-1/2		28		23-3/8		23-1/2	7/8			
G2FD060(S,H)24(T)(X)	24-1/2		28		23-3/8		23-1/2	7/8			
G2FD061H24	24-1/2		33		23-3/8		23-1/2	7/8			

NOTE:
 G2FD coils available with a factory installed horizontal drain pan option (H).
 G2FD061H24 is only available with a factory mounted horizontal pan.
 (T) = Indicates models with factory installed thermal expansion valve. Only available on coils with factory installed horizontal drain pan (H).
 (X) = Models shown with X suffix are available with increased cabinet insulation thickness. Only available on coils without factory installed horizontal drain pan (S) except 061.

G1NA COIL

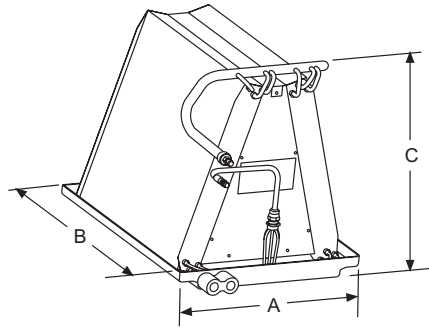

Model	Dimensions — Inches							Refrigerant Connections			
	A	B	C	D	E	F	G	Quick-Connect		Line Size	
								Liquid	Vapor	Liquid	Vapor
G1NA024S17G	16-1/4	19-7/8	14-5/8	—	—	—	—	—	—	3/8	3/4
G1NA030S17H	16-1/4		15-3/4	—	—	—	—	—	—		3/4
G1NA030S17K	16-1/4		17-7/8	—	—	—	—	—	—		3/4
G1NA036S17J	16-1/4		19-5/8	—	—	—	—	—	—		3/4
G1NA036S17L	16-1/4		19-7/8	—	—	—	—	—	—		7/8
G1NA036S21C	19-3/8		19-1/8	—	—	—	—	—	—		3/4
G1NA042S24W	21-3/8	20-3/8	23-7/8	—	—	—	—	—	—	7/8	
G1NA048S21D	19-3/8	19-7/8	19-3/8	—	—	—	—	—	—	7/8	
G1NA060S24T	21-3/8	20-3/8	24-5/8	—	—	—	—	—	—	7/8	

Subject to change without notice. Printed in U.S.A.
 Copyright © by York International Corp. 2005. All rights reserved.

036-21149-004 Rev. B (0405)
 Supersedes: 036-21149-004 Rev. A (0105)