



## TECHNICAL GUIDE

Echelon

SPLIT-SYSTEM HEAT PUMPS

13 SEER – R-22

MODELS: HC3A018 THRU 060  
(1.5 THRU 5 NOMINAL TONS)



Due to continuous product improvement, specifications are subject to change without notice.

Visit us on the web at [www.york.com](http://www.york.com) for the most up-to-date technical information.

Additional rating information can be found at [www.ahridirectory.org](http://www.ahridirectory.org)

## DESCRIPTION

The HC3 Series unit is the outdoor part of a versatile heat pump system. It is designed to be custom matched with one of our complete line of evaporator sections, each designed to serve a specific function. Matching air handlers are available for upflow, downflow, and horizontal left or right application to provide a complete system. Electric heaters are available if required. Add-on coils are available for use with upflow, downflow, or horizontal furnaces. Field installed accessories are available as needed.

## WARRANTY

5-year limited parts warranty.

10-year limited compressor warranty.

## FEATURES

- **Superior Coil Protection** – A PVC coated steel coil guard completely protects coil from debris and other large damaging material while a polymer mesh further protects the coil against smaller particles.
- **Isolated Compressor Compartment** – A molded composite bulkhead isolates the compressor from the rest of the unit reducing sound and vibration.
- **Protected Compressors** – Each compressor is protected against high and low pressure as well as excessive temperature. This is accomplished by the simultaneous operation of a high pressure relief valve and temperature sensors which protect the compressor if undesirable conditions occur.
- **Durable Finish** – Automotive quality finish provides the ultimate protection from harmful U.V. rays as well as rust creep ensuring long-lasting high quality appearance. A powder-paint topcoat is applied over a baked-on primer, using a galvanized, zinc coated steel base material. The result is a finish that has been proven in testing to provide 33% greater durability than conventional powder-coat finishes.
- **Lower Installed Cost** – Designed to provide enhanced installability by featuring a slide-down control compartment allowing easy access to control components along with angled service valves to reduce overall installation time and cost.
- **Low Operating Sound Levels** – A fan design boasting technology adapted from aeronautic and defense engineering provides for whisper quiet operation by allowing airflow to flow smoothly and efficiently across the fan tips.
- **Filter-Drier** – A factory installed, solid core liquid line filter-drier filters harmful debris and moisture from the system.
- **Easy Service Access** – A full end, full service, access panel with handle makes for easy entry to internal components.
- **Long Lasting Operation** – Strong and durable composite base pan provides added strength while resisting rust and corrosion as well as reducing sound and vibration.
- **Complete System Control** – These heat pumps utilize the unique microprocessor defrost control system to provide optimal comfort as well as monitor the overall system for reliable operation. The defrost control system continuously monitors the space environment to maintain optimum efficiency. It initiates defrost only when necessary to further reduced heating costs and improve reliability. Supplemental heat can only operate below the balance point and then only upon need. In the event improper operating conditions occur (high temperature and/or high pressure), the will automatically shut the system down to extend the life of the heat pump. Rapid cycling is prevented by use of an internal anti-cycle timer. The defrost control features an internal memory to aid the technician in troubleshooting, reducing service time and cost.
- **Agency Listed** - U.L. and C.U.L. listed - approved for outdoor application. The unit is certified in accordance with the Unitary Small Equipment certification program, which is based on ARI Standard 210/240.

## Physical and Electrical Data

| MODEL                                     | HC3A018F1           | HC3A024F1           | HC3A030F1           | HC3A036F1 | HC3A042F1           | HC3A048F1           | HC3A060F1           |       |
|---|---------------------|---------------------|---------------------|-----------|---------------------|---------------------|---------------------|-------|
| Unit Supply Voltage                       | 208/230 – 1 – 60    |                     |                     |           |                     |                     |                     |       |
| Normal Voltage Range <sup>1</sup>         | 187 to 252          |                     |                     |           |                     |                     |                     |       |
| Minimum Circuit Ampacity                  | 11.7                | 14.5                | 16.7                | 20.0      | 27.8                | 33.9                | 40.2                |       |
| Max. Overcurrent Device Amps <sup>2</sup> | 20                  | 25                  | 25                  | 30        | 45                  | 50                  | 60                  |       |
| Min. Overcurrent Device Amps <sup>3</sup> | 15                  | 15                  | 20                  | 20        | 30                  | 35                  | 45                  |       |
| Compressor Type <sup>4</sup>              | Scroll <sup>C</sup> | Scroll <sup>C</sup> | Scroll <sup>C</sup> | Recip     | Scroll <sup>D</sup> | Scroll <sup>D</sup> | Scroll <sup>D</sup> |       |
| Compressor Amps                           | Rated Load          | 10.0                | 12.1                | 13.6      | 13.4                | 21.0                | 23.0                | 25.0  |
|   | Locked Rotor        | 41                  | 54                  | 67        | 78                  | 115                 | 115                 | 150   |
| Crankcase Heater                          | No                  | No                  | No                  | Yes       | No                  | No                  | No                  |       |
| Fan Motor Amps                            | Rated Load          | 0.5                 | 0.5                 | 1.5       | 1.5                 | 1.5                 | 1.5                 |       |
| Fan Diameter Inches                       | 22                  | 22                  | 22                  | 24        | 24                  | 24                  | 24                  |       |
| Fan Motor                                 | Rated HP            | 1/15                | 1/15                | 1/4       | 1/4                 | 1/4                 | 1/4                 |       |
|   | Nominal RPM         | 850                 | 850                 | 850       | 850                 | 850                 | 850                 |       |
|   | Nominal CFM         | 1,900               | 1,800               | 3,300     | 3,600               | 3,600               | 3,400               | 3,400 |
| Coil                                      | Face Area Sq. Ft.   | 14.86               | 17.15               | 20.58     | 23.58               | 23.58               | 23.58               |       |
|   | Rows Deep           | 1                   | 1                   | 1         | 1                   | 1                   | 2                   |       |
|   | Fin / Inches        | 22                  | 22                  | 22        | 22                  | 22                  | 22                  |       |
| Liquid Line Set OD (Field Installed)      | 3/8                 | 3/8                 | 3/8                 | 3/8       | 3/8                 | 3/8                 | 3/8                 |       |
| Vapor Line Set OD (Field Installed)       | 3/4                 | 3/4                 | 7/8                 | 7/8       | 7/8                 | 7/8                 | 1-1/8               |       |
| Unit Charge (Lbs. - Oz.) <sup>5</sup>     | 6 - 6               | 7 - 9               | 9 - 1               | 9 - 9     | 10 - 9              | 13 - 1              | 14 - 11             |       |
| Charge Per Foot, Oz.                      | 0.68                | 0.68                | 0.70                | 0.70      | 0.70                | 0.70                | 0.76                |       |
| Operating Weight Lbs.                     | 175                 | 190                 | 195                 | 258       | 258                 | 278                 | 278                 |       |

1 Rated in accordance with ARI Standard 110, utilization range "A".

2 Dual element fuses or HACR circuit breaker. Maximum allowable overcurrent protection.

3 Dual element fuses or HACR circuit breaker. Minimum recommended overcurrent protection.

4 All scrolls listed with superscript "D" are Danfoss scrolls. All scrolls listed with superscripts "C" are Copeland scrolls.

5 The Unit Charge is correct for the outdoor unit, matched indoor coil and 15 feet of refrigerant tubing. For tubing lengths other than 15 feet, add or subtract the amount of refrigerant, using the difference in length multiplied by the per foot value.

All dimensions are in inches. They are subject to change without notice. Certified dimensions will be provided upon request.

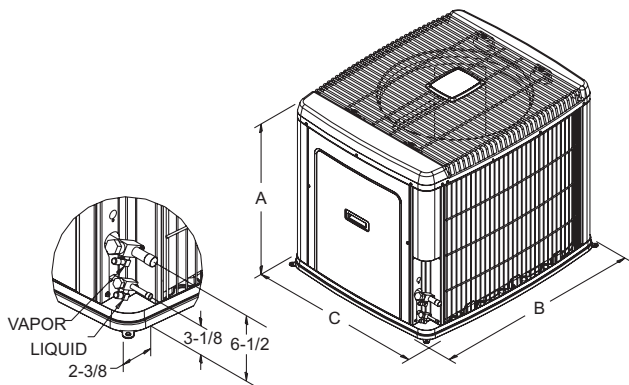

| Unit Model | Dimensions (Inches) |    |    | Refrigerant Connection Service Valve Size |       |
|------------|---------------------|----|----|---|-------|
|            | A                   | B  | C  | Liquid                                    | Vapor |
| 018        | 29-1/2              | 37 | 31 | 3/8"                                      | 3/4"  |
| 024        | 33-1/2              | 37 | 31 |   | 7/8"  |
| 030        | 39-1/2              | 37 | 31 |   |       |
| 036        | 39-1/2              | 42 | 34 |   |       |
| 042        | 39-1/2              | 42 | 34 | 1-1/8"                                    |       |
| 048        | 39-1/2              | 42 | 34 |   |       |
| 060        | 39-1/2              | 42 | 34 |   |       |

\* Expander fitting required for 1-1/8" lineset.

| Additional R-22 Charge / TXV Size for Various Matched Systems |  |           |           |           |           |           |           |
|---|--|-----------|-----------|-----------|-----------|-----------|-----------|
| Outdoor Unit  | HC3A018F1                                    | HC3A024F1 | HC3A030F1 | HC3A036F1 | HC3A042F1 | HC3A048F1 | HC3A060F1 |
| Required TXV <sup>1</sup>                                     | 1TVM2A1                                      | 1TVM2A1   | 1TVM2A1   | 1TVM2A1   | 1TVM2C1   | 1TVM2C1   | 1TVM2C1   |
| Factory Charge, lbs-oz  | 6 - 6  | 7 - 9     | 9 - 1     | 9 - 9     | 10 - 9    | 13 - 1    | 14 - 11   |
| Indoor Coil <sup>2,3</sup>                                    | TXV Kit <sup>4</sup> - Additional Charge, Oz |           |           |           |           |           |           |
| FC/MC/PC/UC18A2A  | 0  | -         | -         | -         | -         | -         | -         |
| FC/MC/PC/UC18B2A  | 0  | -         | -         | -         | -         | -         | -         |
| FC/MC/PC/UC24A2A  | -  | 0         | -         | -         | -         | -         | -         |
| FC/MC/PC/UC24B2A  | -  | 0         | -         | -         | -         | -         | -         |
| FC/MC/PC/UC30A2A  | -  | 0         | -         | -         | -         | -         | -         |
| FC/MC/PC/UC30B2A  | -  | 0         | -         | -         | -         | -         | -         |
| FC/MC/PC35B2A   | -  | -         | 0         | -         | -         | -         | -         |
| FC/MC/PC/UC42B2C  | -  | -         | 0         | -         | -         | -         | -         |
| FC/MC/PC/UC42C2C  | -  | -         | 0         | -         | -         | -         | -         |
| FC/MC/PC/UC48C2C  | -  | -         | -         | 0         | -         | -         | -         |
| FC/MC/PC/UC48D2C  | -  | -         | -         | 0         | -         | -         | -         |
| FC/PC/UC60C2C   | -  | -         | -         | -         | 0         | 0         | 0         |
| FC/MC/PC/UC60D2C  | -  | -         | -         | -         | 0         | 0         | 0         |
| MC61D2C   | -  | -         | -         | -         | -         | 0         | 0         |
| HC18A2A   | 0  | -         | -         | -         | -         | -         | -         |
| HC30A2A   | -  | 0         | -         | -         | -         | -         | -         |
| HC36B2A   | -  | -         | 0         | -         | -         | -         | -         |
| HC42C2C   | -  | -         | -         | 0         | -         | -         | -         |
| HC60D2C   | -  | -         | -         | -         | 0         | 0         | 0         |
| HD24A2A   | -  | 0         | -         | -         | -         | -         | -         |
| HD36B2A   | -  | -         | 0         | -         | -         | -         | -         |
| HD48C2C   | -  | -         | -         | 0         | -         | -         | -         |
| HD60D2C   | -  | -         | -         | -         | 0         | 0         | 0         |
| AHP18B2A  | 0  | -         | -         | -         | -         | -         | -         |
| AHP24B2A  | -  | 0         | -         | -         | -         | -         | -         |
| AHP30B2A  | -  | -         | 0         | -         | -         | -         | -         |
| AHP36C2A  | -  | -         | -         | 0         | -         | -         | -         |
| AHP42C2C  | -  | -         | -         | 0         | -         | -         | -         |
| AHP/SHP48D2C  | -  | -         | -         | -         | 0         | 0         | -         |
| AHP/SHP60D2C  | -  | -         | -         | -         | 0         | 0         | 0         |
| AV24B2A   | 0  | 0         | -         | -         | -         | -         | -         |
| AV36C2A   | -  | -         | 0         | 0         | -         | -         | -         |
| AV/SV48D2C  | -  | -         | -         | -         | 0         | 0         | -         |
| AV/SV60D2C  | -  | -         | -         | -         | 0         | 0         | 0         |
| FC/MC/PC/UC18A3X  | 2A + 0                                       | -         | -         | -         | -         | -         | -         |
| FC/MC/PC/UC18B3X  | 2A + 0                                       | -         | -         | -         | -         | -         | -         |
| FC/MC/PC/UC24A3X  | -  | 2A + 0    | -         | -         | -         | -         | -         |
| FC/MC/PC/UC24B3X  | -  | 2A + 0    | -         | -         | -         | -         | -         |
| FC/MC/PC/UC30A3X  | -  | 2A + 0    | -         | -         | -         | -         | -         |
| FC/MC/PC/UC30B3X  | -  | 2A + 0    | -         | -         | -         | -         | -         |
| FC/MC/PC35B2A   | -  | -         | 2A + 0    | -         | -         | -         | -         |
| FC/MC/PC/UC42B3X  | -  | -         | 2A + 0    | -         | -         | -         | -         |
| FC/MC/PC/UC42C3X  | -  | -         | 2A + 0    | -         | -         | -         | -         |
| FC/MC/PC/UC48C3X  | -  | -         | -         | 2A + 0    | -         | -         | -         |
| FC/MC/PC/UC48D3X  | -  | -         | -         | 2A + 0    | -         | -         | -         |
| FC/PC/UC60C3X   | -  | -         | -         | -         | 2C + 0    | 2C + 0    | 2C + 0    |
| FC/MC/PC/UC60D3X  | -  | -         | -         | -         | 2C + 0    | 2C + 0    | 2C + 0    |
| MC61D3X   | -  | -         | -         | -         | -         | 2C + 0    | 2C + 0    |

For Notes see Page 4.

| <b>Additional R-22 Charge / TXV Size for Various Matched Systems</b> |  |           |           |           |           |           |           |
|--|--|-----------|-----------|-----------|-----------|-----------|-----------|
| Outdoor Unit   | HC3A018F1  | HC3A024F1 | HC3A030F1 | HC3A036F1 | HC3A042F1 | HC3A048F1 | HC3A060F1 |
| Required TXV <sup>1</sup>  | 1TVM2A1  | 1TVM2A1   | 1TVM2A1   | 1TVM2A1   | 1TVM2C1   | 1TVM2C1   | 1TVM2C1   |
| Factory Charge, lbs-oz   | 6 - 6  | 7 - 9     | 9 - 1     | 9 - 9     | 10 - 9    | 13 - 1    | 14 - 11   |
| <b>Indoor Coil<sup>2,3</sup></b>                                     | <b>TXV Kit<sup>4</sup> - Additional Charge, Oz</b> |           |           |           |           |           |           |
| HC18A3X  | 2A + 0   | -         | -         | -         | -         | -         | -         |
| HC30A3X  | -  | 2A + 0    | -         | -         | -         | -         | -         |
| HC36B3X  | -  | -         | 2A + 0    | -         | -         | -         | -         |
| HC42C3X  | -  | -         | -         | 2A + 0    | -         | -         | -         |
| HC60D3X  | -  | -         | -         | -         | 2C + 0    | 2C + 0    | 2C + 0    |
| HD24A3X  | -  | 2A + 0    | -         | -         | -         | -         | -         |
| HD36B3X  | -  | -         | 2A + 0    | -         | -         | -         | -         |
| HD48C3X  | -  | -         | -         | 2A + 0    | -         | -         | -         |
| HD60D3X  | -  | -         | -         | -         | 2C + 0    | 2C + 0    | 2C + 0    |
| AHP18B3X   | 2A + 0   | -         | -         | -         | -         | -         | -         |
| AHP24B3X   | -  | 2A + 0    | -         | -         | -         | -         | -         |
| AHP30B3X   | -  | -         | 2A + 0    | -         | -         | -         | -         |
| AHP36C3X   | -  | -         | -         | 2A + 0    | -         | -         | -         |
| AHP42C3X   | -  | -         | -         | 2A + 0    | -         | -         | -         |
| AHP/SHP48D3X   | -  | -         | -         | -         | 2C + 0    | 2C + 0    | -         |
| AHP/SHP60D3X   | -  | -         | -         | -         | 2C + 0    | 2C + 0    | 2C + 0    |
| AV24B3X  | 2A + 0   | 2A + 0    | -         | -         | -         | -         | -         |
| AV36C3X  | -  | -         | 2A + 0    | 2A + 0    | -         | -         | -         |
| AV/SV48D3X   | -  | -         | -         | -         | 2C + 0    | 2C + 0    | -         |
| AV/SV60D3X   | -  | -         | -         | -         | 2C + 0    | 2C + 0    | 2C + 0    |
| F*FP024H06T2A  | 2A + 0   | -         | -         | -         | -         | -         | -         |
| F*FP040H06T2A  | -  | -         | 2A + 0    | -         | -         | -         | -         |
| F*FP045H06T2C  | -  | -         | -         | -         | 2C + 0    | -         | -         |
| F*FV060H06T2C  | -  | -         | -         | -         | 2C + 0    | 2C + 0    | 2C + 0    |

**FOOTNOTES:**

- 1 A TXV kit must be used with these coils to obtain system performance.
- 2 Systems matched with furnace or air handlers not equipped with blower-off delays may require blower Time Delay Kit 2FD06700224.
- 3 These orifices are factory mounted in the flow device of each indoor coil.
- 4 If not TXV is listed, the indoor coil has the correct valve factory-installed.

**PROCEDURES:**

1. Unit factory charge listed on the unit nameplate includes refrigerant for the condenser, the smallest evaporator and 15 feet of interconnecting line tubing.
2. Verify the TXV and additional charge required for specific evaporator coil in the system using the above table.
3. Additional charge for the amount of interconnecting line tubing greater than 15 feet at the rate specified on the previous page.
4. Permanently mark the unit nameplate with the total system charge. Total System Charge = Base Charge (as shipped) + adder for evaporator + adder for line set.

## COOLING CAPACITY - With Air Handler Coils

| UNIT MODEL  | AIR HANDLER |    | COIL <sup>1</sup><br>MODEL | COOLING      |         |          |       |       |
|---|-------------|----|----------------------------|--------------|---------|----------|-------|-------|
|   | MODEL       | W  |                            | RATED<br>CFM | NET MBH |          | SEER  | EER   |
|   |             |    |                            |              | TOTAL   | SENSIBLE |       |       |
| <b>1 PH 13 SEER HP WITH MA</b>                              |             |    |                            |              |         |          |       |       |
| HC3A018F1   | MA08B       | 17 | FC/MC18B                   | 600          | 17.3    | 12.1     | 13.00 | 11.00 |
| HC3A024F1   | MA08B       | 17 | FC/MC24B                   | 800          | 23.0    | 16.3     | 13.00 | 11.00 |
|   | MA08B       | 17 | FC/MC30B                   | 800          | 23.0    | 16.3     | 13.00 | 11.00 |
| HC3A030F1   | MA12B       | 17 | FC/MC35B                   | 1000         | 28.6    | 20.3     | 13.00 | 11.00 |
|   | MA12B       | 17 | FC/MC42B                   | 1000         | 28.6    | 20.3     | 13.00 | 11.00 |
| HC3A036F1   | MA12B       | 17 | FC/MC42B                   | 1200         | 34.6    | 25.0     | 13.00 | 11.00 |
|   | MA14D       | 24 | FC/MC48D                   | 1200         | 35.2    | 25.5     | 13.50 | 11.00 |
| HC3A042F1   | MA16C       | 21 | FC60C                      | 1400         | 41.5    | 30.7     | 13.00 | 11.00 |
|   | MA14D       | 24 | FC/MC60D                   | 1400         | 41.5    | 30.7     | 13.00 | 11.00 |
| HC3A048F1   | MA16C       | 21 | FC60C                      | 1600         | 47.0    | 34.2     | 13.00 | 11.00 |
|   | MA20D       | 24 | FC/MC60D                   | 1600         | 47.0    | 34.2     | 13.00 | 11.00 |
| HC3A060F1   | MA20D       | 24 | FC/MC60D                   | 1800         | 55.0    | 37.9     | 13.00 | 11.00 |
|   | MA20D       | 24 | MC61D                      | 1800         | 55.5    | 38.3     | 13.00 | 11.00 |
| <b>1 PH 13 SEER HP WITH MV - VARIABLE SPEED</b>             |             |    |                            |              |         |          |       |       |
| HC3A018F1   | MV12B       | 17 | FC/MC18B                   | 600          | 17.5    | 12.0     | 14.00 | 11.50 |
| HC3A024F1   | MV12B       | 17 | FC/MC24B                   | 800          | 23.4    | 16.3     | 14.00 | 11.50 |
|   | MV12B       | 17 | FC/MC30B                   | 800          | 23.4    | 16.3     | 14.00 | 11.50 |
| HC3A030F1   | MV12B       | 17 | FC/MC35B                   | 1000         | 29.0    | 20.1     | 14.00 | 11.50 |
|   | MV12B       | 17 | FC/MC42B                   | 1000         | 29.0    | 20.1     | 14.00 | 11.50 |
| HC3A036F1   | MV16C       | 21 | FC/MC48C                   | 1200         | 36.0    | 25.3     | 14.00 | 11.50 |
|   | MV20D       | 24 | FC/MC48D                   | 1200         | 36.0    | 25.3     | 14.00 | 11.50 |
| HC3A042F1   | MV16C       | 21 | FC60C                      | 1400         | 41.0    | 29.6     | 13.50 | 11.00 |
|   | MV20D       | 24 | FC/MC60D                   | 1400         | 42.0    | 30.2     | 14.00 | 11.50 |
| HC3A048F1   | MV16C       | 21 | FC60C                      | 1600         | 46.0    | 32.7     | 13.25 | 11.00 |
|   | MV20D       | 24 | FC/MC60D                   | 1600         | 47.0    | 33.3     | 13.50 | 11.00 |
| HC3A060F1   | MV20D       | 24 | FC/MC60D                   | 1800         | 55.0    | 37.2     | 13.25 | 11.00 |
|   | MV20D       | 24 | MC61D                      | 1800         | 55.5    | 37.6     | 13.25 | 11.00 |
| <b>1 PH 13 SEER HP WITH AV / SV / F*FV - VARIABLE SPEED</b> |             |    |                            |              |         |          |       |       |
| HC3A018F1   | AV24        | 17 | —                          | 600          | 17.5    | 12.0     | 14.00 | 11.50 |
| HC3A024F1   | AV24        | 17 | —                          | 800          | 23.4    | 16.3     | 14.00 | 11.50 |
| HC3A030F1   | AV36        | 21 | —                          | 1000         | 29.0    | 20.1     | 14.00 | 11.50 |
| HC3A036F1   | AV36        | 21 | —                          | 1200         | 36.0    | 25.3     | 14.00 | 11.50 |
| HC3A042F1   | AV/SV48     | 24 | —                          | 1400         | 42.0    | 30.2     | 14.00 | 11.50 |
|   | AV/SV60     | 24 | —                          | 1400         | 42.0    | 30.2     | 14.00 | 11.50 |
|   | F*FV060     | 24 | —                          | 1400         | 42.0    | 30.2     | 14.00 | 11.50 |
| HC3A048F1   | AV/SV48     | 24 | —                          | 1600         | 47.0    | 33.3     | 13.50 | 11.00 |
|   | AV/SV60     | 24 | —                          | 1600         | 47.0    | 33.3     | 13.50 | 11.00 |
|   | F*FV060     | 24 | —                          | 1600         | 47.0    | 33.3     | 13.50 | 11.00 |
| HC3A060F1   | AV/SV60     | 24 | —                          | 1800         | 55.0    | 37.2     | 13.25 | 11.00 |
|   | F*FV060     | 24 | —                          | 1800         | 55.0    | 37.2     | 13.00 | 11.00 |
| <b>1 PH 13 SEER HP WITH AHP / SHP / F*FP</b>                |             |    |                            |              |         |          |       |       |
| HC3A018F1   | AHP18       | 17 | —                          | 650          | 17.4    | 12.7     | 13.00 | 11.00 |
|   | F*FP024     | 17 | —                          | 600          | 17.3    | 12.1     | 13.00 | 11.00 |
| HC3A024F1   | AHP24       | 17 | —                          | 830          | 23.0    | 16.5     | 13.00 | 11.00 |
| HC3A030F1   | AHP30       | 17 | —                          | 1015         | 28.8    | 20.4     | 13.00 | 11.00 |
|   | F*FP040     | 17 | —                          | 1000         | 28.6    | 20.3     | 13.00 | 11.00 |
| HC3A036F1   | AHP36       | 21 | —                          | 1200         | 35.2    | 25.5     | 13.50 | 11.00 |
|   | AHP42       | 21 | —                          | 1200         | 35.2    | 25.5     | 13.50 | 11.00 |
| HC3A042F1   | AHP/SHP48   | 21 | —                          | 1400         | 41.5    | 30.7     | 13.00 | 11.00 |
|   | AHP/SHP60   | 24 | —                          | 1400         | 42.0    | 30.8     | 14.00 | 11.50 |
|   | F*FP045     | 21 | —                          | 1400         | 41.5    | 30.7     | 13.00 | 11.00 |
| HC3A048F1   | AHP/SHP48   | 21 | —                          | 1675         | 47.0    | 35.0     | 13.00 | 11.00 |
|   | AHP/SHP60   | 24 | —                          | 1600         | 47.0    | 34.2     | 13.50 | 11.00 |
| HC3A060F1   | AHP/SHP60   | 24 | —                          | 1850         | 55.0    | 38.7     | 13.00 | 11.00 |

Rated in accordance with DOE test procedures (Federal Register 12-27-79 and 3-18-88) and ARI Standards 210.

Cooling MBH based on 80°F entering air temperature, 50% RH, and rated air flow.

EER (Energy Efficiency Ratio) is the total cooling output in BTU's at 95°F outdoor ambient divided by the total electric power in watt-hours at those conditions.

SEER (Seasonal Energy Efficiency Ratio) is the total cooling output in BTU's during a normal annual usage period for cooling divided by the total electric power input in watt-hours during the same period.

1 MC coils available with a factory installed horizontal drain pan. See price pages for specific model number.

— = Not applicable.

Go to [www.ari.org/ari directory](http://www.ari.org/ari directory) for the latest additional matches.

**COOLING CAPACITY - Upflow, Downflow & Horizontal Furnaces and Coils**

| UNIT MODEL | FURNACE**                |       | COIL MODEL    | COOLING      |         |          |                   |       |
|------------|--------------------------|-------|---------------|--------------|---------|----------|-------------------|-------|
|            | CFM RANGE<br>(Min.-max.) | W     |               | RATED<br>CFM | NET MBH |          | SEER <sup>1</sup> | EER   |
|            |                          |       |               |              | TOTAL   | SENSIBLE |                   |       |
| HC3A018F1  | 400<br>800               | 14,17 | FC/MC/PC/UC18 | 600          | 17.3    | 12.1     | 13.00             | 11.00 |
|            |                          | 14    | HC18          | 600          | 17.3    | 12.1     | 13.00             | 11.00 |
| HC3A024F1  | 600<br>1000              | 14,17 | FC/MC/PC/UC24 | 800          | 23.0    | 16.3     | 13.00             | 11.00 |
|            |                          | 14,17 | FC/MC/PC/UC30 | 800          | 23.0    | 16.3     | 13.00             | 11.00 |
|            |                          | 21    | HC30          | 800          | 23.2    | 16.5     | 13.00             | 11.00 |
|            |                          | –     | HD24          | 800          | 23.4    | 16.7     | 13.00             | 11.00 |
| HC3A030F1  | 800<br>1200              | 17,21 | FC/MC/PC/UC35 | 1000         | 28.6    | 20.3     | 13.00             | 11.00 |
|            |                          | 17,21 | FC/MC/PC/UC42 | 1000         | 28.6    | 20.3     | 13.00             | 11.00 |
|            |                          | 17    | HC36          | 1000         | 28.8    | 20.3     | 13.00             | 11.00 |
|            |                          | –     | HD36          | 1000         | 28.8    | 20.3     | 13.00             | 11.00 |
| HC3A036F1  | 1000<br>1400             | 17,21 | FC/MC/PC/UC42 | 1200         | 34.6    | 25.0     | 13.00             | 11.00 |
|            |                          | 21,24 | FC/MC/PC/UC48 | 1200         | 35.2    | 25.5     | 13.50             | 11.00 |
|            |                          | 21    | HC42          | 1200         | 35.4    | 25.0     | 13.50             | 11.00 |
|            |                          | –     | HD48          | 1200         | 36.0    | 26.0     | 13.50             | 11.00 |
| HC3A042F1  | 1200<br>1600             | 21,24 | FC/MC/PC/UC60 | 1400         | 41.5    | 30.7     | 13.00             | 11.00 |
|            |                          | 24    | HC60          | 1400         | 41.5    | 30.7     | 13.00             | 11.00 |
|            |                          | –     | HD60          | 1400         | 41.5    | 30.8     | 13.00             | 11.00 |
| HC3A048F1  | 1400<br>1800             | 21,24 | FC/MC/PC/UC60 | 1600         | 47.0    | 34.2     | 13.00             | 11.00 |
|            |                          | 24    | HC60          | 1600         | 47.0    | 34.2     | 13.00             | 11.00 |
|            |                          | –     | HD60          | 1600         | 47.0    | 34.3     | 13.00             | 11.00 |
| HC3A060F1  | 1600<br>2000             | 21,24 | FC/MC/PC/UC60 | 1800         | 55.0    | 37.9     | 13.00             | 11.00 |
|            |                          | 24    | MC61          | 1800         | 55.5    | 38.3     | 13.00             | 11.00 |
|            |                          | 24    | HC60          | 1800         | 55.0    | 37.9     | 13.00             | 11.00 |
|            |                          | –     | HD60          | 1800         | 55.0    | 38.3     | 13.00             | 11.00 |

1 Requires a 2FD06700224 Blower Time Delay unless a standard furnace is equipped with one.

**COOLING CAPACITY - HC3A018F1With Variable Speed Furnaces**

| VARIABLE SPEED<br>FURNACE MODEL                            | COIL<br>MODEL <sup>1</sup> | W  | COOLING      |         |          |       |       |
|--|----------------------------|----|--------------|---------|----------|-------|-------|
|  |                            |    | RATED<br>CFM | NET MBH |          | SEER  | EER   |
|  |                            |    |              | TOTAL   | SENSIBLE |       |       |
| <b>1 PH 13 SEER HP WITH - VARIABLE SPEED<sup>2,3</sup></b> |                            |    |              |         |          |       |       |
| (F,L)C8V*A12   | FC/MC/PC18A                | 14 | 600          | 17.6    | 12.2     | 14.00 | 11.50 |
| FC9V*A12   | FC/MC/PC18A                | 14 | 600          | 17.6    | 12.2     | 14.00 | 11.50 |
| FC9(C,V)*B12   | FC/MC/PC18B                | 17 | 600          | 17.6    | 12.2     | 14.00 | 11.50 |
| (F,L)C8V*A12   | HC18                       | 14 | 600          | 17.6    | 12.2     | 14.00 | 11.50 |
| FC9V*A12   | HC18                       | 14 | 600          | 17.6    | 12.2     | 14.00 | 11.50 |
| C*(8,L)C*A12   | FC/MC/PC18A                | 14 | 620          | 17.8    | 12.7     | 15.30 | 12.90 |
| C*(8,L)C*B12   | FC/MC/PC18B                | 17 | 580          | 17.6    | 12.4     | 15.30 | 12.90 |
| C*9C*B12   | FC/MC/PC18B                | 17 | 610          | 17.8    | 12.7     | 15.50 | 13.10 |
| C*(8,L)C*A12   | FC/MC/PC24A                | 14 | 640          | 18.0    | 13.2     | 15.50 | 12.70 |
| C*(8,L)C*B12   | FC/MC/PC24B                | 17 | 575          | 18.0    | 12.6     | 15.80 | 13.30 |
| C*9C*B12   | FC/MC/PC24B                | 17 | 610          | 18.0    | 13.2     | 15.60 | 12.80 |
| C*(8,L)C*A12   | HC18                       | 14 | 620          | 17.8    | 12.7     | 15.30 | 12.90 |
| C*(8,L)C*A12   | HD24                       | 14 | 640          | 18.0    | 13.1     | 15.70 | 13.10 |
| C*(8,L)C*B12   | HD24                       | 17 | 575          | 18.0    | 12.6     | 15.80 | 13.40 |
| C*9C*B12   | HD24                       | 17 | 610          | 18.0    | 13.1     | 15.80 | 13.30 |
| C*(8,L)C*A12   | UC18A                      | 14 | 620          | 17.9    | 12.9     | 15.50 | 13.00 |
| C*(8,L)C*B12   | UC18B                      | 17 | 580          | 17.9    | 12.6     | 15.40 | 13.20 |
| C*9C*B12   | UC18B                      | 17 | 610          | 17.9    | 12.8     | 15.70 | 13.20 |
| C*(8,L)C*A12   | UC24A                      | 14 | 640          | 17.9    | 13.3     | 15.70 | 12.60 |
| C*(8,L)C*B12   | UC24B                      | 17 | 575          | 18.0    | 12.7     | 15.70 | 13.50 |
| C*9C*B12   | UC24B                      | 17 | 610          | 17.9    | 13.3     | 15.90 | 12.80 |
| G*9V*A12   | FC/MC/PC18A                | 14 | 625          | 17.8    | 12.7     | 15.20 | 12.70 |
| G*9V*B12   | FC/MC/PC18B                | 17 | 610          | 17.8    | 12.7     | 15.50 | 13.10 |
| G*9V*A12   | FC/MC/PC24A                | 14 | 625          | 18.0    | 13.0     | 15.20 | 12.90 |
| G*9V*B12   | FC/MC/PC24B                | 17 | 610          | 18.0    | 13.2     | 15.60 | 12.80 |
| G*9V*A12   | HC18                       | 14 | 625          | 17.8    | 12.7     | 15.20 | 12.70 |
| G*9V*A12   | HD24                       | 14 | 625          | 18.0    | 12.9     | 15.20 | 13.00 |
| G*9V*B12   | HD24                       | 17 | 610          | 18.0    | 13.1     | 15.80 | 13.30 |
| G*9V*A12   | UC18A                      | 14 | 625          | 18.0    | 12.9     | 15.20 | 12.90 |
| G*9V*B12   | UC18B                      | 17 | 610          | 17.9    | 12.8     | 15.70 | 13.20 |
| G*9V*A12   | UC24A                      | 14 | 625          | 18.0    | 13.1     | 15.40 | 12.90 |
| G*9V*B12   | UC24B                      | 17 | 610          | 17.9    | 13.3     | 15.90 | 12.80 |

- 1 MC coils available with a factory installed horizontal drain pan. See price pages for specific model number.
- 2 Variable speed furnaces have B.O.D (Blower on Delay) standard.
- 3 HC60D coils matched to "C" width furnaces will require field supplied transition or modification.

**COOLING CAPACITY - HC3A024F1With Variable Speed Furnaces**

| VARIABLE SPEED<br>FURNACE MODEL                            | COIL<br>MODEL <sup>1</sup> | W  | COOLING      |         |          |       |       |
|--|----------------------------|----|--------------|---------|----------|-------|-------|
|  |                            |    | RATED<br>CFM | NET MBH |          | SEER  | EER   |
|  |                            |    |              | TOTAL   | SENSIBLE |       |       |
| <b>1 PH 13 SEER HP WITH - VARIABLE SPEED<sup>2,3</sup></b> |                            |    |              |         |          |       |       |
| (F,L)C8V*A12   | FC/MC/PC24A                | 14 | 800          | 23.2    | 16.5     | 14.00 | 11.50 |
| FC9V*A12   | FC/MC/PC24A                | 14 | 800          | 23.2    | 16.5     | 14.00 | 11.50 |
| FC9(C,V)*B12   | FC/MC/PC24B                | 17 | 800          | 23.2    | 16.5     | 14.00 | 11.50 |
| (F,L)C8V*A12   | FC/MC/PC30A                | 14 | 800          | 23.2    | 16.5     | 14.00 | 11.50 |
| FC9V*A12   | FC/MC/PC30A                | 14 | 800          | 23.2    | 16.5     | 14.00 | 11.50 |
| FC9(C,V)*B12   | FC/MC/PC30B                | 17 | 800          | 23.2    | 16.5     | 14.00 | 11.50 |
| (F,L)C8V*A12   | HC30                       | 14 | 800          | 23.6    | 16.7     | 14.00 | 11.50 |
| FC9V*A12   | HC30                       | 14 | 800          | 23.6    | 16.7     | 14.00 | 11.50 |
| (F,L)C8V*A12   | HD24                       | –  | 800          | 23.8    | 16.9     | 14.00 | 11.50 |
| FC9V*A12   | HD24                       | –  | 800          | 23.8    | 16.9     | 14.00 | 11.50 |
| C*(8,L)C*A12   | FC/MC/PC24A                | 14 | 805          | 23.6    | 16.9     | 14.80 | 12.20 |
| C*(8,L)C*B12   | FC/MC/PC24B                | 17 | 815          | 23.6    | 17.0     | 15.10 | 12.40 |
| C*9C*B12   | FC/MC/PC24B                | 17 | 790          | 23.4    | 16.7     | 14.70 | 12.20 |
| C*(8,L)C*A12   | FC/MC/PC30A                | 14 | 805          | 23.6    | 16.9     | 14.80 | 12.20 |
| C*(8,L)C*B12   | FC/MC/PC30B                | 17 | 815          | 23.6    | 17.0     | 15.10 | 12.40 |
| C*9C*B12   | FC/MC/PC30B                | 17 | 790          | 23.4    | 16.7     | 14.70 | 12.20 |
| C*(8,L)C*A12   | FC/MC/PC32A                | 14 | 775          | 23.6    | 16.8     | 14.70 | 12.20 |
| C*(8,L)C*A12   | HC30                       | 14 | 775          | 23.4    | 16.5     | 14.40 | 12.00 |
| C*(8,L)C*A12   | HD24                       | 14 | 805          | 23.6    | 16.9     | 14.90 | 12.30 |
| C*(8,L)C*B12   | HD24                       | 17 | 815          | 23.6    | 17.0     | 15.10 | 12.40 |
| C*9C*B12   | HD24                       | 17 | 790          | 23.6    | 16.9     | 14.80 | 12.30 |
| C*(8,L)C*A12   | UC24A                      | 14 | 805          | 23.6    | 16.9     | 14.70 | 12.20 |
| C*(8,L)C*B12   | UC24B                      | 17 | 815          | 23.6    | 17.0     | 14.90 | 12.40 |
| C*9C*B12   | UC24B                      | 17 | 790          | 23.6    | 16.9     | 14.60 | 12.20 |
| C*(8,L)C*A12   | UC30A                      | 14 | 805          | 23.6    | 16.9     | 14.70 | 12.20 |
| C*(8,L)C*B12   | UC30B                      | 17 | 815          | 23.6    | 17.0     | 14.90 | 12.40 |
| C*9C*B12   | UC30B                      | 17 | 790          | 23.6    | 16.9     | 14.60 | 12.20 |
| G*9V*A12   | FC/MC/PC24A                | 14 | 800          | 23.4    | 16.7     | 14.50 | 12.00 |
| G*9V*B12   | FC/MC/PC24B                | 17 | 790          | 23.4    | 16.7     | 14.70 | 12.20 |
| G*9V*A12   | FC/MC/PC30A                | 14 | 800          | 23.4    | 16.7     | 14.50 | 12.00 |
| G*9V*B12   | FC/MC/PC30B                | 17 | 790          | 23.4    | 16.7     | 14.70 | 12.20 |
| G*9V*A12   | FC/MC/PC32A                | 14 | 800          | 23.6    | 16.9     | 14.30 | 11.90 |
| G*9V*A12   | HC30                       | 14 | 800          | 23.4    | 16.8     | 14.50 | 12.00 |
| G*9V*A12   | HD24                       | 14 | 800          | 23.6    | 16.8     | 14.40 | 12.00 |
| G*9V*B12   | HD24                       | 17 | 790          | 23.6    | 16.9     | 14.80 | 12.30 |
| G*9V*A12   | UC24A                      | 14 | 800          | 23.4    | 16.8     | 14.40 | 12.00 |
| G*9V*B12   | UC24B                      | 17 | 790          | 23.6    | 16.9     | 14.60 | 12.20 |
| G*9V*A12   | UC30A                      | 14 | 800          | 23.4    | 16.8     | 14.40 | 12.00 |
| G*9V*B12   | UC30B                      | 17 | 790          | 23.6    | 16.9     | 14.60 | 12.20 |

1 MC coils available with a factory installed horizontal drain pan. See price pages for specific model number.

2 Variable speed furnaces have B.O.D (Blower on Delay) standard.

3 HC60D coils matched to "C" width furnaces will require field supplied transition or modification.

**COOLING CAPACITY - HC3A030F1With Variable Speed Furnaces**

| VARIABLE SPEED<br>FURNACE MODEL                            | COIL<br>MODEL <sup>1</sup> | W  | COOLING      |         |          |       |       |
|--|----------------------------|----|--------------|---------|----------|-------|-------|
|  |                            |    | RATED<br>CFM | NET MBH |          | SEER  | EER   |
|  |                            |    |              | TOTAL   | SENSIBLE |       |       |
| <b>1 PH 13 SEER HP WITH - VARIABLE SPEED<sup>2,3</sup></b> |                            |    |              |         |          |       |       |
| (F,L)C8V*B16   | FC/MC/PC35B                | 17 | 1000         | 29.2    | 20.5     | 14.00 | 11.50 |
| FC9(C,V)*B12   | FC/MC/PC35B                | 17 | 1000         | 29.0    | 20.4     | 14.00 | 11.50 |
| (F,L)C8V*B16   | HC36                       | 17 | 1000         | 29.2    | 20.5     | 14.00 | 11.50 |
| FC9(C,V)*B12   | HC36                       | 17 | 1000         | 29.2    | 20.5     | 14.00 | 11.50 |
| (F,L)C8V*A12   | HD36                       | –  | 1000         | 29.0    | 20.4     | 14.00 | 11.50 |
| (F,L)C8V*B16   | HD36                       | –  | 1000         | 29.2    | 20.5     | 14.00 | 11.50 |
| (F,L)C8V*C16   | HD36                       | –  | 1000         | 29.4    | 20.5     | 14.00 | 11.50 |
| (F,L)C8V*C20   | HD36                       | –  | 1000         | 29.4    | 20.6     | 14.00 | 11.50 |
| FC9V*A12   | HD36                       | –  | 1000         | 29.0    | 20.4     | 13.75 | 11.00 |
| FC9(C,V)*B12   | HD36                       | –  | 1000         | 29.2    | 20.5     | 14.00 | 11.50 |
| FC9(C,V)*C16   | HD36                       | –  | 1000         | 29.2    | 20.5     | 14.00 | 11.50 |
| FC9(C,V)*C20   | HD36                       | –  | 1000         | 29.2    | 20.5     | 14.00 | 11.50 |
| C*(8,L)C*A12   | FC/MC/PC32A                | 14 | 1045         | 29.0    | 21.0     | 13.60 | 11.60 |
| C*(8,L)C*B12   | FC/MC/PC35B                | 17 | 995          | 29.4    | 21.2     | 14.50 | 12.30 |
| C*9C*B12   | FC/MC/PC35B                | 17 | 1045         | 29.2    | 21.2     | 14.00 | 12.00 |
| C*(8,L)C*C16   | FC/MC/PC35C                | 21 | 1025         | 29.6    | 21.2     | 14.70 | 12.50 |
| C*(8,L)C*C20   | FC/MC/PC35C                | 21 | 1080         | 29.6    | 21.8     | 14.80 | 12.50 |
| C*9C*C16   | FC/MC/PC35C                | 21 | 1005         | 29.4    | 21.2     | 14.70 | 12.50 |
| C*9C*C20   | FC/MC/PC35C                | 21 | 985          | 29.4    | 21.2     | 14.70 | 12.50 |
| C*(8,L)C*A12   | FC/MC/PC37A                | 14 | 980          | 29.2    | 21.0     | 14.10 | 12.00 |
| G*9V*A12   | FC/MC/PC30A                | 14 | 1000         | 28.6    | 20.2     | 14.00 | 11.90 |
| G*9V*A12   | FC/MC/PC32A                | 14 | 1000         | 29.2    | 20.8     | 14.10 | 12.10 |
| G*9V*B12   | FC/MC/PC35B                | 17 | 1045         | 29.2    | 21.2     | 14.00 | 12.00 |
| G*9V*C16   | FC/MC/PC35C                | 21 | 1005         | 29.4    | 21.2     | 14.70 | 12.50 |
| G*9V*C20   | FC/MC/PC35C                | 21 | 985          | 29.4    | 21.2     | 14.70 | 12.50 |
| G*9V*A12   | FC/MC/PC37A                | 14 | 1000         | 29.4    | 21.2     | 14.10 | 12.00 |

- 1 MC coils available with a factory installed horizontal drain pan. See price pages for specific model number.
- 2 Variable speed furnaces have B.O.D (Blower on Delay) standard.
- 3 HC60D coils matched to "C" width furnaces will require field supplied transition or modification.

**COOLING CAPACITY - HC3A036F1With Variable Speed Furnaces**

| VARIABLE SPEED<br>FURNACE MODEL                            | COIL<br>MODEL <sup>1</sup> | W  | COOLING      |         |          |       |       |
|--|----------------------------|----|--------------|---------|----------|-------|-------|
|  |                            |    | RATED<br>CFM | NET MBH |          | SEER  | EER   |
|  |                            |    |              | TOTAL   | SENSIBLE |       |       |
| <b>1 PH 13 SEER HP WITH - VARIABLE SPEED<sup>2,3</sup></b> |                            |    |              |         |          |       |       |
| (F,L)C8V*B16   | FC/MC/PC42B                | 17 | 1200         | 35.0    | 25.0     | 14.00 | 11.50 |
| FC9(C,V)*B12   | FC/MC/PC42B                | 17 | 1200         | 35.0    | 25.0     | 13.50 | 11.00 |
| (F,L)C8V*C16   | FC/MC/PC42C                | 21 | 1200         | 35.0    | 25.0     | 13.50 | 11.00 |
| (F,L)C8V*C20   | FC/MC/PC42C                | 21 | 1200         | 35.0    | 25.0     | 14.00 | 11.50 |
| FC9(C,V)*C16   | FC/MC/PC42C                | 21 | 1200         | 35.0    | 25.0     | 13.50 | 11.00 |
| FC9(C,V)*C20   | FC/MC/PC42C                | 21 | 1200         | 35.0    | 25.0     | 14.00 | 11.50 |
| (F,L)C8V*C16   | FC/MC/PC48C                | 21 | 1200         | 36.0    | 25.7     | 14.00 | 11.50 |
| (F,L)C8V*C20   | FC/MC/PC48C                | 21 | 1200         | 36.0    | 25.7     | 14.00 | 11.50 |
| FC9(C,V)*C16   | FC/MC/PC48C                | 21 | 1200         | 35.8    | 25.7     | 14.00 | 11.50 |
| FC9(C,V)*C20   | FC/MC/PC48C                | 21 | 1200         | 36.0    | 25.7     | 14.00 | 11.50 |
| FC9(C,V)*D20   | FC/MC/PC48D                | 24 | 1200         | 36.0    | 25.7     | 14.00 | 11.50 |
| (F,L)C8V*C16   | HC42                       | 21 | 1200         | 36.0    | 25.9     | 14.00 | 11.50 |
| (F,L)C8V*C20   | HC42                       | 21 | 1200         | 36.0    | 25.9     | 14.00 | 11.50 |
| FC9(C,V)*C16   | HC42                       | 21 | 1200         | 36.0    | 25.9     | 14.00 | 11.50 |
| FC9(C,V)*C20   | HC42                       | 21 | 1200         | 36.0    | 25.9     | 14.00 | 11.50 |

For Notes see Page 10.

**COOLING CAPACITY - HC3A036F1With Variable Speed Furnaces**

| VARIABLE SPEED<br>FURNACE MODEL                            | COIL<br>MODEL <sup>1</sup> | W  | COOLING      |         |          |       |       |
|--|----------------------------|----|--------------|---------|----------|-------|-------|
|  |                            |    | RATED<br>CFM | NET MBH |          | SEER  | EER   |
|  |                            |    |              | TOTAL   | SENSIBLE |       |       |
| <b>1 PH 13 SEER HP WITH - VARIABLE SPEED<sup>2,3</sup></b> |                            |    |              |         |          |       |       |
| (F,L)C8V*C16   | HD48                       | –  | 1200         | 36.0    | 25.9     | 14.00 | 11.50 |
| (F,L)C8V*C20   | HD48                       | –  | 1200         | 36.0    | 25.9     | 14.00 | 11.50 |
| FC9(C,V)*C16   | HD48                       | –  | 1200         | 36.0    | 25.9     | 14.00 | 11.50 |
| FC9(C,V)*C20   | HD48                       | –  | 1200         | 36.0    | 25.9     | 14.00 | 11.50 |
| FC9(C,V)*D20   | HD48                       | –  | 1200         | 36.0    | 25.8     | 14.00 | 11.50 |
| C*(8,L)C*A12   | FC/MC/PC37A                | 14 | 980          | 35.2    | 25.0     | 14.60 | 12.50 |
| C*(8,L)C*B12   | FC/MC/PC43B                | 17 | 1210         | 36.0    | 27.2     | 14.50 | 12.40 |
| C*9C*B12   | FC/MC/PC43B                | 17 | 1200         | 36.0    | 27.2     | 14.50 | 12.40 |
| C*(8,L)C*C16   | FC/MC/PC43C                | 21 | 1205         | 36.0    | 27.2     | 15.20 | 13.00 |
| C*(8,L)C*C20   | FC/MC/PC43C                | 21 | 1190         | 36.0    | 27.2     | 15.30 | 13.10 |
| C*9C*C16   | FC/MC/PC43C                | 21 | 1240         | 36.0    | 27.2     | 14.70 | 12.60 |
| C*9C*C20   | FC/MC/PC43C                | 21 | 1200         | 36.0    | 27.2     | 15.10 | 12.90 |
| C*(8,L)C*C16   | FC/MC/PC48C                | 21 | 1210         | 36.0    | 27.4     | 15.60 | 13.20 |
| C*(8,L)C*C20   | FC/MC/PC48C                | 21 | 1155         | 36.0    | 27.4     | 15.80 | 13.40 |
| C*9C*C16   | FC/MC/PC48C                | 21 | 1195         | 36.0    | 27.4     | 15.40 | 13.00 |
| C*9C*C20   | FC/MC/PC48C                | 21 | 1330         | 36.0    | 28.2     | 15.00 | 12.80 |
| C*(8,L)C*C16   | HC42                       | 21 | 1205         | 36.0    | 27.2     | 15.20 | 13.00 |
| C*(8,L)C*C20   | HC42                       | 21 | 1190         | 36.0    | 27.2     | 15.40 | 13.10 |
| C*9C*C16   | HC42                       | 21 | 1240         | 36.0    | 27.2     | 14.70 | 12.60 |
| C*9C*C20   | HC42                       | 21 | 1200         | 36.0    | 27.2     | 15.10 | 12.90 |
| C*(8,L)C*B12   | HD48                       | 17 | 1210         | 36.0    | 27.0     | 14.80 | 12.60 |
| C*(8,L)C*C16   | HD48                       | 21 | 1210         | 36.0    | 27.0     | 15.30 | 13.10 |
| C*(8,L)C*C20   | HD48                       | 21 | 1155         | 36.0    | 27.0     | 15.50 | 13.20 |
| C*9C*B12   | HD48                       | 17 | 1150         | 36.0    | 27.0     | 14.70 | 12.50 |
| C*9C*C16   | HD48                       | 21 | 1195         | 36.0    | 27.0     | 15.10 | 12.90 |
| C*9C*C20   | HD48                       | 21 | 1330         | 36.0    | 27.8     | 14.80 | 12.70 |
| C*(8,L)C*C16   | UC48C                      | 21 | 1210         | 36.0    | 27.4     | 15.50 | 13.20 |
| C*(8,L)C*C20   | UC48C                      | 21 | 1155         | 36.0    | 27.4     | 15.70 | 13.40 |
| C*9C*C16   | UC48C                      | 21 | 1195         | 36.0    | 27.4     | 15.30 | 13.00 |
| C*9C*C20   | UC48C                      | 21 | 1330         | 36.0    | 28.2     | 15.00 | 12.80 |
| G*9V*A12   | FC/MC/PC37A                | 14 | 1100         | 35.6    | 26.0     | 14.30 | 12.20 |
| G*9V*B12   | FC/MC/PC43B                | 17 | 1200         | 36.0    | 27.2     | 14.50 | 12.40 |
| G*9V*C16   | FC/MC/PC43C                | 21 | 1240         | 36.0    | 27.2     | 14.70 | 12.60 |
| G*9V*C20   | FC/MC/PC43C                | 21 | 1200         | 36.0    | 27.2     | 15.10 | 12.90 |
| G*9V*C16   | FC/MC/PC48C                | 21 | 1195         | 36.0    | 27.4     | 15.40 | 13.00 |
| G*9V*C20   | FC/MC/PC48C                | 21 | 1330         | 36.0    | 28.2     | 15.00 | 12.80 |
| G*9V*C16   | HC42                       | 21 | 1240         | 36.0    | 27.2     | 14.70 | 12.60 |
| G*9V*C20   | HC42                       | 21 | 1200         | 36.0    | 27.2     | 15.10 | 12.90 |
| G*9V*B12   | HD48                       | 17 | 1150         | 36.0    | 27.0     | 14.70 | 12.50 |
| G*9V*C16   | HD48                       | 21 | 1195         | 36.0    | 27.0     | 15.10 | 12.90 |
| G*9V*C20   | HD48                       | 21 | 1330         | 36.0    | 27.8     | 14.80 | 12.70 |
| G*9V*C16   | UC48C                      | 21 | 1195         | 36.0    | 27.4     | 15.30 | 13.00 |
| G*9V*C20   | UC48C                      | 21 | 1330         | 36.0    | 28.2     | 15.00 | 12.80 |

- 1 MC coils available with a factory installed horizontal drain pan. See price pages for specific model number.
- 2 Variable speed furnaces have B.O.D (Blower on Delay) standard.
- 3 HC60D coils matched to "C" width furnaces will require field supplied transition or modification.

## COOLING CAPACITY - HC3A042F1With Variable Speed Furnaces

| VARIABLE SPEED<br>FURNACE MODEL                            | COIL<br>MODEL <sup>1</sup> | W  | COOLING      |         |          |       |       |
|--|----------------------------|----|--------------|---------|----------|-------|-------|
|  |                            |    | RATED<br>CFM | NET MBH |          | SEER  | EER   |
|  |                            |    |              | TOTAL   | SENSIBLE |       |       |
| <b>1 PH 13 SEER HP WITH - VARIABLE SPEED<sup>2,3</sup></b> |                            |    |              |         |          |       |       |
| (F,L)C8V*C16   | FC/PC60C                   | 21 | 1400         | 41.5    | 30.8     | 13.50 | 11.00 |
| (F,L)C8V*C20   | FC/PC60C                   | 21 | 1400         | 42.0    | 30.8     | 13.50 | 11.00 |
| FC9(C,V)*C16   | FC/PC60C                   | 21 | 1400         | 41.5    | 30.8     | 13.50 | 11.00 |
| FC9(C,V)*C20   | FC/PC60C                   | 21 | 1400         | 41.5    | 30.8     | 13.50 | 11.00 |
| FC9(C,V)*D20   | FC/MC/PC60D                | 24 | 1400         | 41.5    | 30.8     | 13.50 | 11.00 |
| (F,L)C8V*C20   | HC60                       | 21 | 1400         | 42.0    | 30.8     | 13.50 | 11.00 |
| FC9(C,V)*C20   | HC60                       | 21 | 1400         | 41.5    | 30.8     | 13.50 | 11.00 |
| FC9(C,V)*D20   | HC60                       | 24 | 1400         | 41.5    | 30.8     | 13.50 | 11.00 |
| (F,L)C8V*C16   | HD60                       | -  | 1400         | 42.0    | 30.8     | 13.50 | 11.00 |
| (F,L)C8V*C20   | HD60                       | -  | 1400         | 42.0    | 30.8     | 13.50 | 11.00 |
| FC9(C,V)*C16   | HD60                       | -  | 1400         | 42.0    | 30.8     | 13.50 | 11.00 |
| FC9(C,V)*C20   | HD60                       | -  | 1400         | 42.0    | 30.8     | 13.50 | 11.00 |
| FC9(C,V)*D20   | HD60                       | -  | 1400         | 41.5    | 30.7     | 13.50 | 11.00 |
| C*9C*D20   | FC/MC/PC60D                | 24 | 1445         | 42.0    | 32.0     | 13.80 | 11.90 |
| C*(8,L)C*C16   | FC/PC60C                   | 21 | 1420         | 42.0    | 31.8     | 13.90 | 11.80 |
| C*(8,L)C*C20   | FC/PC60C                   | 21 | 1410         | 42.0    | 31.8     | 14.00 | 12.00 |
| C*9C*C16   | FC/PC60C                   | 21 | 1445         | 42.0    | 31.8     | 13.40 | 11.50 |
| C*9C*C20   | FC/PC60C                   | 21 | 1445         | 42.0    | 32.0     | 13.60 | 11.70 |
| C*9C*D20   | FC/MC62D                   | 24 | 1455         | 42.0    | 32.2     | 13.80 | 11.90 |
| C*(8,L)C*C16   | HC60                       | 21 | 1420         | 42.0    | 31.8     | 13.90 | 11.90 |
| C*(8,L)C*C20   | HC60                       | 21 | 1410         | 42.0    | 31.8     | 14.10 | 12.10 |
| C*9C*C16   | HC60                       | 21 | 1445         | 42.0    | 31.8     | 13.30 | 11.50 |
| C*9C*C20   | HC60                       | 21 | 1445         | 42.0    | 31.8     | 13.60 | 11.70 |
| C*9C*D20   | HC60                       | 24 | 1445         | 42.0    | 31.8     | 13.70 | 11.90 |
| C*(8,L)C*C16   | HD60                       | 21 | 1420         | 42.0    | 31.8     | 13.70 | 11.80 |
| C*(8,L)C*C20   | HD60                       | 21 | 1410         | 42.0    | 31.8     | 13.90 | 11.90 |
| C*9C*C16   | HD60                       | 21 | 1445         | 42.0    | 31.8     | 13.10 | 11.30 |
| C*9C*C20   | HD60                       | 21 | 1445         | 42.0    | 31.8     | 13.40 | 11.50 |
| C*9C*D20   | HD60                       | 24 | 1445         | 42.0    | 31.8     | 13.50 | 11.70 |
| C*(8,L)C*C16   | UC60C                      | 21 | 1420         | 42.0    | 31.6     | 13.60 | 11.80 |
| C*(8,L)C*C20   | UC60C                      | 21 | 1410         | 42.0    | 31.6     | 13.90 | 11.90 |
| C*9C*C16   | UC60C                      | 21 | 1445         | 42.0    | 31.6     | 13.10 | 11.30 |
| C*9C*C20   | UC60C                      | 21 | 1445         | 42.0    | 31.6     | 13.40 | 11.60 |
| C*9C*D20   | UC60D                      | 24 | 1445         | 42.0    | 31.6     | 13.50 | 11.70 |
| G*9V*D20   | FC/MC/PC60D                | 24 | 1445         | 42.0    | 32.0     | 13.80 | 11.90 |
| G*9V*C16   | FC/PC60C                   | 21 | 1445         | 42.0    | 31.8     | 13.40 | 11.50 |
| G*9V*C20   | FC/PC60C                   | 21 | 1445         | 42.0    | 32.0     | 13.60 | 11.70 |
| G*9V*D20   | FC/MC62D                   | 24 | 1455         | 42.0    | 32.2     | 13.80 | 11.90 |
| G*9V*C16   | HC60                       | 21 | 1445         | 42.0    | 31.8     | 13.30 | 11.50 |
| G*9V*C20   | HC60                       | 21 | 1445         | 42.0    | 31.8     | 13.60 | 11.70 |
| G*9V*D20   | HC60                       | 24 | 1445         | 42.0    | 31.8     | 13.70 | 11.90 |
| G*9V*C16   | HD60                       | 21 | 1445         | 42.0    | 31.8     | 13.10 | 11.30 |
| G*9V*C20   | HD60                       | 21 | 1445         | 42.0    | 31.8     | 13.40 | 11.50 |
| G*9V*D20   | HD60                       | 24 | 1445         | 42.0    | 31.8     | 13.50 | 11.70 |
| G*9V*C16   | UC60C                      | 21 | 1445         | 42.0    | 31.6     | 13.10 | 11.30 |
| G*9V*C20   | UC60C                      | 21 | 1445         | 42.0    | 31.6     | 13.40 | 11.60 |
| G*9V*D20   | UC60D                      | 24 | 1445         | 42.0    | 31.6     | 13.50 | 11.70 |

1 MC coils available with a factory installed horizontal drain pan. See price pages for specific model number.

2 Variable speed furnaces have B.O.D (Blower on Delay) standard.

3 HC60D coils matched to "C" width furnaces will require field supplied transition or modification.

**COOLING CAPACITY - HC3A048F1With Variable Speed Furnaces**

| VARIABLE SPEED<br>FURNACE MODEL                            | COIL<br>MODEL <sup>1</sup> | W  | COOLING      |         |          |       |       |
|--|----------------------------|----|--------------|---------|----------|-------|-------|
|  |                            |    | RATED<br>CFM | NET MBH |          | SEER  | EER   |
|  |                            |    |              | TOTAL   | SENSIBLE |       |       |
| <b>1 PH 13 SEER HP WITH - VARIABLE SPEED<sup>2,3</sup></b> |                            |    |              |         |          |       |       |
| (F,L)C8V*C16   | FC/PC60C                   | 21 | 1500         | 47.0    | 33.1     | 13.00 | 11.00 |
| (F,L)C8V*C20   | FC/PC60C                   | 21 | 1600         | 47.0    | 34.1     | 13.25 | 11.00 |
| FC9(C,V)*C16   | FC/PC60C                   | 21 | 1600         | 47.0    | 34.2     | 13.00 | 11.00 |
| FC9(C,V)*C20   | FC/PC60C                   | 21 | 1600         | 47.0    | 34.1     | 13.00 | 11.00 |
| FC9(C,V)*D20   | FC/MC/PC60D                | 24 | 1600         | 47.0    | 34.1     | 13.25 | 11.00 |
| (F,L)C8V*C20   | HC60                       | 21 | 1600         | 47.0    | 34.1     | 13.25 | 11.00 |
| FC9(C,V)*C20   | HC60                       | 21 | 1600         | 47.0    | 34.1     | 13.00 | 11.00 |
| FC9(C,V)*D20   | HC60                       | 24 | 1600         | 47.0    | 34.1     | 13.25 | 11.00 |
| (F,L)C8V*C16   | HD60                       | –  | 1500         | 47.0    | 33.1     | 13.25 | 11.00 |
| (F,L)C8V*C20   | HD60                       | –  | 1600         | 47.0    | 34.4     | 13.25 | 11.00 |
| FC9(C,V)*C16   | HD60                       | –  | 1600         | 47.0    | 34.4     | 13.00 | 11.00 |
| FC9(C,V)*C20   | HD60                       | –  | 1600         | 47.0    | 34.4     | 13.25 | 11.00 |
| FC9(C,V)*D20   | HD60                       | –  | 1600         | 47.0    | 34.4     | 13.25 | 11.00 |
| C*9C*D20   | FC/MC/PC60D                | 24 | 1615         | 48.0    | 36.0     | 13.70 | 12.00 |
| C*9C*D20   | FC/MC62D                   | 24 | 1630         | 48.0    | 36.2     | 13.80 | 12.20 |
| C*(8,L)C*C16   | FC/PC60C                   | 21 | 1625         | 48.0    | 36.0     | 13.90 | 12.30 |
| C*(8,L)C*C20   | FC/PC60C                   | 21 | 1605         | 48.0    | 36.0     | 14.20 | 12.50 |
| C*9C*C16   | FC/PC60C                   | 21 | 1590         | 48.0    | 36.0     | 13.70 | 12.10 |
| C*9C*C20   | FC/PC60C                   | 21 | 1655         | 48.0    | 36.0     | 13.70 | 12.10 |
| C*(8,L)C*C16   | HD60                       | 21 | 1625         | 47.0    | 35.8     | 13.80 | 11.90 |
| C*(8,L)C*C20   | HD60                       | 21 | 1605         | 47.0    | 36.0     | 14.10 | 12.20 |
| C*9C*C16   | HD60                       | 21 | 1590         | 47.0    | 35.8     | 13.60 | 11.80 |
| C*9C*C20   | HD60                       | 21 | 1655         | 47.0    | 35.8     | 13.60 | 11.80 |
| C*9C*D20   | HD60                       | 24 | 1615         | 47.0    | 35.8     | 13.70 | 11.90 |
| C*(8,L)C*C16   | UC60C                      | 21 | 1625         | 47.5    | 35.6     | 13.80 | 12.10 |
| C*(8,L)C*C20   | UC60C                      | 21 | 1605         | 48.0    | 35.6     | 14.10 | 12.30 |
| C*9C*C16   | UC60C                      | 21 | 1590         | 47.5    | 35.4     | 13.50 | 11.90 |
| C*9C*C20   | UC60C                      | 21 | 1655         | 47.5    | 35.4     | 13.50 | 11.90 |
| C*9C*D20   | UC60D                      | 24 | 1615         | 47.5    | 35.4     | 13.60 | 12.00 |
| G*9V*D20   | FC/MC/PC60D                | 24 | 1615         | 48.0    | 36.0     | 13.70 | 12.00 |
| G*9V*D20   | FC/MC62D                   | 24 | 1630         | 48.0    | 36.2     | 13.80 | 12.20 |
| G*9V*C16   | FC/PC60C                   | 21 | 1590         | 48.0    | 36.0     | 13.70 | 12.10 |
| G*9V*C20   | FC/PC60C                   | 21 | 1655         | 48.0    | 36.0     | 13.70 | 12.10 |
| G*9V*C16   | HD60                       | 21 | 1590         | 47.0    | 35.8     | 13.60 | 11.80 |
| G*9V*C20   | HD60                       | 21 | 1655         | 47.0    | 35.8     | 13.60 | 11.80 |
| G*9V*D20   | HD60                       | 24 | 1615         | 47.0    | 35.8     | 13.70 | 11.90 |
| G*9V*C16   | UC60C                      | 21 | 1590         | 47.5    | 35.4     | 13.50 | 11.90 |
| G*9V*C20   | UC60C                      | 21 | 1655         | 47.5    | 35.4     | 13.50 | 11.90 |
| G*9V*D20   | UC60D                      | 24 | 1615         | 47.5    | 35.4     | 13.60 | 12.00 |

1 MC coils available with a factory installed horizontal drain pan. See price pages for specific model number.

2 Variable speed furnaces have B.O.D (Blower on Delay) standard.

3 HC60D coils matched to "C" width furnaces will require field supplied transition or modification.

**COOLING CAPACITY - HC3A060F1With Variable Speed Furnaces**

| VARIABLE SPEED<br>FURNACE MODEL                            | COIL<br>MODEL <sup>1</sup> | W  | COOLING      |         |          |       |       |
|--|----------------------------|----|--------------|---------|----------|-------|-------|
|  |                            |    | RATED<br>CFM | NET MBH |          | SEER  | EER   |
|  |                            |    |              | TOTAL   | SENSIBLE |       |       |
| <b>1 PH 13 SEER HP WITH - VARIABLE SPEED<sup>2,3</sup></b> |                            |    |              |         |          |       |       |
| (F,L)C8V*C20   | FC/PC60C                   | 21 | 1730         | 55.0    | 37.5     | 13.00 | 11.00 |
| FC9(C,V)*C20   | FC/PC60C                   | 21 | 1620         | 54.5    | 36.0     | 13.00 | 11.00 |
| FC9(C,V)*D20   | FC/MC/PC60D                | 24 | 1620         | 54.5    | 36.1     | 13.25 | 11.00 |
| (F,L)C8V*C20   | MC61D                      | 21 | 1730         | 55.5    | 37.8     | 13.25 | 11.00 |
| FC9(C,V)*C20   | MC61D                      | 21 | 1620         | 54.0    | 36.5     | 13.00 | 11.00 |
| FC9(C,V)*D20   | MC61D                      | 24 | 1620         | 55.0    | 36.6     | 13.25 | 11.00 |
| (F,L)C8V*C20   | HC60                       | 21 | 1730         | 55.0    | 37.5     | 13.00 | 11.00 |
| FC9(C,V)*D20   | HC60                       | 24 | 1620         | 54.5    | 36.1     | 13.25 | 11.00 |
| (F,L)C8V*C20   | HD60                       | –  | 1730         | 55.0    | 37.4     | 13.00 | 11.00 |
| FC9(C,V)*C20   | HD60                       | –  | 1620         | 54.5    | 36.4     | 13.00 | 11.00 |
| FC9(C,V)*D20   | HD60                       | –  | 1620         | 54.0    | 36.4     | 13.25 | 11.00 |
| C*9C*D20   | FC/MC/PC60D                | 24 | 1615         | 55.0    | 38.5     | 13.30 | 11.50 |
| C*(8,L)C*C20   | FC/MC62D                   | 21 | 1615         | 55.5    | 39.0     | 13.60 | 11.80 |
| C*9C*D20   | FC/MC62D                   | 24 | 1630         | 55.0    | 39.0     | 13.30 | 11.50 |
| C*(8,L)C*C20   | FC/PC60C                   | 21 | 1605         | 55.5    | 38.5     | 13.60 | 11.80 |
| C*9C*C20   | FC/PC60C                   | 21 | 1655         | 55.5    | 38.5     | 13.20 | 11.50 |
| C*9C*D20   | HC60                       | 24 | 1615         | 55.5    | 38.5     | 13.30 | 11.60 |
| C*(8,L)C*C20   | HD60                       | 21 | 1605         | 54.0    | 37.8     | 13.50 | 11.50 |
| C*9C*C20   | HD60                       | 21 | 1655         | 55.0    | 39.0     | 13.20 | 11.40 |
| C*9C*D20   | HD60                       | 24 | 1615         | 53.5    | 37.8     | 13.20 | 11.20 |
| C*(8,L)C*C20   | UC60C                      | 21 | 1605         | 55.0    | 38.0     | 13.30 | 11.70 |
| C*9C*C20   | UC60C                      | 21 | 1655         | 54.5    | 37.6     | 13.00 | 11.40 |
| C*9C*D20   | UC60D                      | 24 | 1615         | 54.5    | 37.8     | 13.00 | 11.50 |
| G*9V*D20   | FC/MC/PC60D                | 24 | 1615         | 55.0    | 38.5     | 13.30 | 11.50 |
| G*9V*D20   | FC/MC62D                   | 24 | 1630         | 55.0    | 39.0     | 13.30 | 11.50 |
| G*9V*C20   | FC/PC60C                   | 21 | 1655         | 55.5    | 38.5     | 13.20 | 11.50 |
| G*9V*D20   | HC60                       | 24 | 1615         | 55.5    | 38.5     | 13.30 | 11.60 |
| G*9V*C20   | HD60                       | 21 | 1655         | 55.0    | 39.0     | 13.20 | 11.40 |
| G*9V*D20   | HD60                       | 24 | 1615         | 53.5    | 37.8     | 13.20 | 11.20 |
| G*9V*C20   | UC60C                      | 21 | 1655         | 54.5    | 37.6     | 13.00 | 11.40 |
| G*9V*D20   | UC60D                      | 24 | 1615         | 54.5    | 37.8     | 13.00 | 11.50 |

1 MC coils available with a factory installed horizontal drain pan. See price pages for specific model number.

2 Variable speed furnaces have B.O.D (Blower on Delay) standard.

3 HC60D coils matched to "C" width furnaces will require field supplied transition or modification.

## HEATING PERFORMANCE - Air Handlers

| UNIT MODEL*   | AIR HANDLER | COIL <sup>1</sup> MODEL | ARI HEATING <sup>2</sup> |      |      |      |      |      |      |
|---|-------------|-------------------------|--------------------------|------|------|------|------|------|------|
|   |             |                         | 47°F                     |      |      | 17°F |      |      | HSPF |
|   |             |                         | MBH                      | COP  | KW   | MBH  | COP  | KW   | STD  |
| <b>1 PH 13 SEER HP WITH MA</b>                            |             |                         |                          |      |      |      |      |      |      |
| HC3A018F1   | MA08B       | FC/MC18B                | 17.5                     | 3.40 | 1.51 | 10.6 | 2.40 | 1.29 | 8.00 |
| HC3A024F1   | MA08B       | FC/MC24B                | 23.6                     | 3.20 | 2.16 | 14.6 | 2.20 | 1.94 | 8.00 |
|   | MA08B       | FC/MC30B                | 23.6                     | 3.20 | 2.16 | 14.6 | 2.20 | 1.94 | 8.00 |
| HC3A030F1   | MA12B       | FC/MC35B                | 29.6                     | 3.40 | 2.55 | 18.0 | 2.20 | 2.40 | 8.00 |
|   | MA12B       | FC/MC42B                | 29.6                     | 3.40 | 2.55 | 18.0 | 2.20 | 2.40 | 8.00 |
| HC3A036F1   | MA12B       | FC/MC42B                | 35.0                     | 4.00 | 2.78 | 22.6 | 2.58 | 2.58 | 8.75 |
|   | MA14D       | FC/MC48D                | 36.0                     | 4.00 | 2.78 | 22.6 | 2.58 | 2.58 | 9.00 |
| HC3A042F1   | MA16C       | FC60C                   | 42.0                     | 3.76 | 3.27 | 29.0 | 2.54 | 3.34 | 8.60 |
|   | MA14D       | FC/MC60D                | 42.0                     | 3.76 | 3.27 | 29.0 | 2.54 | 3.34 | 8.60 |
| HC3A048F1   | MA16C       | FC60C                   | 48.0                     | 3.76 | 3.74 | 33.4 | 2.58 | 3.79 | 8.60 |
|   | MA20D       | FC/MC60D                | 48.0                     | 3.76 | 3.74 | 33.4 | 2.58 | 3.79 | 8.60 |
| HC3A060F1   | MA20D       | FC/MC60D                | 58.0                     | 3.58 | 4.75 | 40.0 | 2.40 | 4.88 | 8.00 |
|   | MA20D       | MC61D                   | 58.0                     | 3.58 | 4.75 | 40.0 | 2.40 | 4.88 | 8.00 |
| <b>1 PH 13 SEER HP WITH MV - VARIABLE SPEED</b>           |             |                         |                          |      |      |      |      |      |      |
| HC3A018F1   | MV12B       | FC/MC18B                | 17.1                     | 3.60 | 1.39 | 10.3 | 2.54 | 1.19 | 8.50 |
| HC3A024F1   | MV12B       | FC/MC24B                | 23.2                     | 3.38 | 2.01 | 14.0 | 2.30 | 1.78 | 8.30 |
|   | MV12B       | FC/MC30B                | 23.2                     | 3.38 | 2.01 | 14.0 | 2.30 | 1.78 | 8.30 |
| HC3A030F1   | MV12B       | FC/MC35B                | 29.0                     | 3.58 | 2.37 | 17.3 | 2.30 | 2.20 | 8.35 |
|   | MV12B       | FC/MC42B                | 29.0                     | 3.58 | 2.37 | 17.3 | 2.28 | 2.22 | 8.30 |
| HC3A036F1   | MV16C       | FC/MC48C                | 36.0                     | 4.18 | 2.62 | 22.2 | 2.70 | 2.41 | 9.50 |
|   | MV20D       | FC/MC8D                 | 36.0                     | 4.24 | 2.57 | 22.2 | 2.74 | 2.35 | 9.60 |
| HC3A042F1   | MV16C       | FC60C                   | 42.0                     | 3.92 | 3.14 | 28.2 | 2.66 | 3.11 | 8.85 |
|   | MV20D       | FC/MC60D                | 42.0                     | 3.92 | 3.14 | 28.2 | 2.66 | 3.11 | 8.85 |
| HC3A048F1   | MV16C       | FC60C                   | 48.0                     | 3.86 | 3.64 | 33.0 | 2.66 | 3.63 | 8.75 |
|   | MV20D       | FC/MC60D                | 48.0                     | 3.86 | 3.64 | 33.0 | 2.66 | 3.63 | 8.75 |
| HC3A060F1   | MV20D       | FC/MC60D                | 58.0                     | 3.64 | 4.67 | 39.5 | 2.42 | 4.78 | 8.15 |
|   | MV20D       | MC61D                   | 58.0                     | 3.66 | 4.64 | 39.5 | 2.44 | 4.74 | 8.20 |
| <b>1 PH 13 SEER HP WITH AV / SV / FV - VARIABLE SPEED</b> |             |                         |                          |      |      |      |      |      |      |
| HC3A018F1   | AV24        | —                       | 17.1                     | 3.60 | 1.39 | 10.3 | 2.54 | 1.19 | 8.50 |
| HC3A024F1   | AV24        | —                       | 23.2                     | 3.38 | 2.01 | 14.0 | 2.30 | 1.78 | 8.30 |
| HC3A030F1   | AV36        | —                       | 29.0                     | 3.58 | 2.37 | 17.3 | 2.30 | 2.20 | 8.35 |
| HC3A036F1   | AV36        | —                       | 36.0                     | 4.18 | 2.62 | 22.2 | 2.70 | 2.41 | 9.50 |
| HC3A042F1   | AV/SV48     | —                       | 42.0                     | 3.92 | 3.14 | 28.2 | 2.66 | 3.11 | 8.85 |
|   | AV/SV60     | —                       | 42.0                     | 3.92 | 3.14 | 28.2 | 2.66 | 3.11 | 8.85 |
|   | F*FV060     | —                       | 42.0                     | 3.92 | 3.14 | 28.2 | 2.66 | 3.11 | 8.85 |
| HC3A048F1   | AV/SV48     | —                       | 48.0                     | 3.86 | 3.64 | 33.0 | 2.66 | 3.63 | 8.75 |
|   | AV/SV60     | —                       | 48.0                     | 3.86 | 3.64 | 33.0 | 2.66 | 3.63 | 8.75 |
|   | F*FV060     | —                       | 48.0                     | 3.86 | 3.64 | 33.0 | 2.66 | 3.63 | 8.75 |
| HC3A060F1   | AV/SV60     | —                       | 58.0                     | 3.64 | 4.67 | 39.5 | 2.42 | 4.78 | 8.15 |
|   | F*FV060     | —                       | 58.0                     | 3.64 | 4.67 | 39.5 | 2.42 | 4.78 | 8.15 |
| <b>1 PH 13 SEER HP WITH AHP/ SHP</b>                      |             |                         |                          |      |      |      |      |      |      |
| HC3A018F1   | AHP18       | —                       | 17.5                     | 3.40 | 1.51 | 10.6 | 2.40 | 1.29 | 8.00 |
|   | F*FP024     | —                       | 17.5                     | 3.40 | 1.51 | 10.6 | 2.40 | 1.29 | 8.00 |
| HC3A024F1   | AHP24       | —                       | 23.6                     | 3.20 | 2.16 | 14.6 | 2.20 | 1.94 | 8.00 |
| HC3A030F1   | AHP30       | —                       | 29.6                     | 3.40 | 2.55 | 18.0 | 2.20 | 2.40 | 8.00 |
|   | F*FP040     | —                       | 29.6                     | 3.40 | 2.55 | 18.0 | 2.20 | 2.40 | 8.00 |
| HC3A036F1   | AHP36       | —                       | 36.0                     | 4.00 | 2.78 | 22.6 | 2.58 | 2.58 | 9.25 |
|   | AHP42       | —                       | 36.0                     | 4.00 | 2.78 | 22.6 | 2.58 | 2.58 | 9.25 |
| HC3A042F1   | AHP/SHP48   | —                       | 42.0                     | 3.78 | 3.25 | 28.8 | 2.56 | 3.30 | 8.60 |
|   | AHP/SHP60   | —                       | 42.0                     | 3.90 | 3.15 | 28.2 | 2.64 | 3.13 | 8.80 |
|   | F*FP045     | —                       | 42.0                     | 3.78 | 3.25 | 28.8 | 2.56 | 3.30 | 8.60 |
| HC3A048F1   | AHP/SHP48   | —                       | 48.0                     | 3.72 | 3.78 | 33.4 | 2.58 | 3.79 | 8.50 |
|   | AHP/SHP60   | —                       | 48.0                     | 3.82 | 3.68 | 33.0 | 2.66 | 3.63 | 8.70 |
| HC3A060F1   | AHP/SHP60   | —                       | 58.0                     | 3.60 | 4.72 | 39.0 | 2.40 | 4.76 | 8.05 |

1 Rated CFM same as for cooling.

2 Heating MBH based on ARI standards of 70° DB entering indoor air, 72% RH outdoor air with 25 feet of interconnecting piping and no supplemental electric heat operation.

CP equals MBH output divided by (total KW input x 3.412).

HSPF (Heating Seasonal Performance Factor) is the total heating output during a normal annual usage period for heating divided by the total electric power input during the same period.

— = Not Applicable.

## HEATING PERFORMANCE - Furnace Coils

| UNIT<br>MODEL* | COIL <sup>1</sup><br>MODEL | ARI HEATING <sup>2</sup> |      |      |      |      |      |      |
|----------------|----------------------------|--------------------------|------|------|------|------|------|------|
|                |                            | 47°F                     |      |      | 17°F |      |      | HSPF |
|                |                            | MBH                      | COP  | KW   | MBH  | COP  | KW   | STD  |
| HC3A018F1      | FC/MC/PC/UC18              | 17.5                     | 3.40 | 1.51 | 10.6 | 2.40 | 1.29 | 8.00 |
|                | HC18                       | 17.5                     | 3.40 | 1.51 | 10.6 | 2.40 | 1.29 | 8.00 |
| HC3A024F1      | FC/MC/PC/UC24              | 23.6                     | 3.20 | 2.16 | 14.6 | 2.20 | 1.94 | 8.00 |
|                | FC/MC/PC/UC30              | 23.6                     | 3.20 | 2.16 | 14.6 | 2.20 | 1.94 | 8.00 |
|                | HC30                       | 23.6                     | 3.20 | 2.16 | 14.6 | 2.20 | 1.94 | 8.00 |
|                | HD24                       | 23.6                     | 3.20 | 2.16 | 14.6 | 2.20 | 1.94 | 8.00 |
| HC3A030F1      | FC/MC/PC35                 | 29.6                     | 3.40 | 2.55 | 18.0 | 2.20 | 2.40 | 8.00 |
|                | FC/MC/PC/UC42              | 29.6                     | 3.40 | 2.55 | 18.0 | 2.20 | 2.40 | 8.00 |
|                | HC36                       | 29.6                     | 3.40 | 2.55 | 18.0 | 2.20 | 2.40 | 8.00 |
|                | HD36                       | 29.6                     | 3.40 | 2.55 | 18.0 | 2.20 | 2.40 | 8.00 |
| HC3A036F1      | FC/MC/PC/UC42              | 35.0                     | 4.00 | 2.78 | 22.6 | 2.58 | 2.57 | 8.50 |
|                | FC/MC/PC/UC48              | 36.0                     | 4.00 | 2.78 | 22.6 | 2.58 | 2.57 | 8.50 |
|                | HC42                       | 36.0                     | 4.00 | 2.78 | 22.6 | 2.58 | 2.57 | 8.50 |
|                | HD48                       | 36.0                     | 4.00 | 2.78 | 22.6 | 2.58 | 2.57 | 8.50 |
| HC3A042F1      | FC/MC/PC/UC60              | 42.0                     | 3.76 | 3.27 | 29.0 | 2.54 | 3.34 | 8.50 |
|                | HC60                       | 42.0                     | 3.76 | 3.27 | 29.0 | 2.54 | 3.34 | 8.50 |
|                | HD60                       | 42.0                     | 3.76 | 3.27 | 29.0 | 2.54 | 3.34 | 8.50 |
| HC3A048F1      | FC/MC/PC/UC60              | 48.0                     | 3.76 | 3.74 | 33.4 | 2.58 | 3.79 | 8.60 |
|                | HC60                       | 48.0                     | 3.76 | 3.74 | 33.4 | 2.58 | 3.79 | 8.60 |
|                | HD60                       | 48.0                     | 3.76 | 3.74 | 33.4 | 2.58 | 3.79 | 8.60 |
| HC3A060F1      | FC/MC/PC/UC60              | 58.0                     | 3.58 | 4.75 | 40.0 | 2.40 | 4.88 | 8.00 |
|                | MC61                       | 58.0                     | 3.58 | 4.75 | 40.0 | 2.40 | 4.88 | 8.00 |
|                | HC60                       | 58.0                     | 3.58 | 4.75 | 40.0 | 2.40 | 4.88 | 8.00 |
|                | HD60                       | 58.0                     | 3.58 | 4.75 | 40.0 | 2.40 | 4.88 | 8.00 |

1 Rated CFM same as for cooling.

2 Heating MBH based on ARI standards of 70° DB entering indoor air, 72% RH outdoor air with 25 feet of interconnecting piping and no supplemental electric heat operation.

COP equals MBH output divided by (total KW input x 3.412).

HSPF (Heating Seasonal Performance Factor) is the total heating output during a normal annual usage period for heating divided by the total electric power input during the same period.

**HEATING CAPACITY - HC3A018F1With Variable Speed Furnaces**

| VARIABLE<br>SPEED<br>FURNACE                               | COIL <sup>1</sup><br>MODEL | ARI HEATING <sup>2</sup> |      |      |      |      |      |      |
|--|----------------------------|--------------------------|------|------|------|------|------|------|
|  |                            | 47°F                     |      |      | 17°F |      |      | HSPF |
|  |                            | MBH                      | COP  | KW   | MBH  | COP  | KW   | STD  |
| <b>13 SEER HP WITH VARIABLE SPEED FURNACES<sup>3</sup></b> |                            |                          |      |      |      |      |      |      |
| (F,L)C8V*A12   | FC/MC/PC18A                | 17.0                     | 3.64 | 1.37 | 10.2 | 2.56 | 1.17 | 8.50 |
| FC9V*A12   | FC/MC/PC18A                | 17.1                     | 3.58 | 1.40 | 10.3 | 2.52 | 1.20 | 8.50 |
| FC9(C,V)*B12   | FC/MC/PC18B                | 17.0                     | 3.62 | 1.38 | 10.2 | 2.56 | 1.17 | 8.50 |
| (F,L)C8V*A12   | HC18                       | 17.0                     | 3.64 | 1.37 | 10.2 | 2.56 | 1.17 | 8.50 |
| FC9V*A12   | HC18                       | 17.1                     | 3.58 | 1.40 | 10.3 | 2.52 | 1.20 | 8.50 |
| C*(8,L)C*A12   | FC/MC/PC18A                | 17.1                     | 3.66 | 1.37 | 10.5 | 2.52 | 1.22 | 8.30 |
| C*(8,L)C*B12   | FC/MC/PC18B                | 17.0                     | 3.62 | 1.38 | 10.6 | 2.48 | 1.25 | 8.30 |
| C*9C*B12   | FC/MC/PC18B                | 17.0                     | 3.68 | 1.35 | 10.5 | 2.54 | 1.21 | 8.30 |
| C*(8,L)C*A12   | FC/MC/PC24A                | 17.2                     | 3.86 | 1.31 | 10.3 | 2.68 | 1.13 | 8.30 |
| C*(8,L)C*B12   | FC/MC/PC24B                | 17.1                     | 3.80 | 1.32 | 10.2 | 2.68 | 1.12 | 8.40 |
| C*9C*B12   | FC/MC/PC24B                | 17.2                     | 3.88 | 1.30 | 10.3 | 2.70 | 1.12 | 8.40 |
| C*(8,L)C*A12   | HC18                       | 17.1                     | 3.66 | 1.37 | 10.5 | 2.52 | 1.22 | 8.30 |
| C*(8,L)C*A12   | HD24                       | 17.1                     | 3.74 | 1.34 | 10.3 | 2.54 | 1.19 | 8.30 |
| C*(8,L)C*B12   | HD24                       | 17.0                     | 3.66 | 1.36 | 10.2 | 2.52 | 1.19 | 8.30 |
| C*9C*B12   | HD24                       | 17.1                     | 3.76 | 1.33 | 10.2 | 2.56 | 1.17 | 8.30 |
| C*(8,L)C*A12   | UC18A                      | 17.1                     | 3.72 | 1.35 | 10.4 | 2.58 | 1.18 | 8.30 |
| C*(8,L)C*B12   | UC18B                      | 17.0                     | 3.66 | 1.36 | 10.4 | 2.56 | 1.19 | 8.30 |
| C*9C*B12   | UC18B                      | 17.1                     | 3.72 | 1.35 | 10.3 | 2.62 | 1.15 | 8.30 |
| C*(8,L)C*A12   | UC24A                      | 17.2                     | 3.88 | 1.30 | 10.3 | 2.68 | 1.13 | 8.30 |
| C*(8,L)C*B12   | UC24B                      | 17.1                     | 3.84 | 1.31 | 10.3 | 2.68 | 1.13 | 8.40 |
| C*9C*B12   | UC24B                      | 17.2                     | 3.92 | 1.29 | 10.3 | 2.70 | 1.12 | 8.40 |
| G*9V*A12   | FC/MC/PC18A                | 17.2                     | 3.64 | 1.38 | 10.4 | 2.54 | 1.20 | 8.20 |
| G*9V*B12   | FC/MC/PC18B                | 17.0                     | 3.68 | 1.35 | 10.5 | 2.54 | 1.21 | 8.30 |
| G*9V*A12   | FC/MC/PC24A                | 17.3                     | 3.80 | 1.33 | 10.4 | 2.62 | 1.16 | 8.30 |
| G*9V*B12   | FC/MC/PC24B                | 17.2                     | 3.88 | 1.30 | 10.3 | 2.70 | 1.12 | 8.40 |
| G*9V*A12   | HC18                       | 17.2                     | 3.64 | 1.38 | 10.4 | 2.54 | 1.20 | 8.20 |
| G*9V*A12   | HD24                       | 17.2                     | 3.68 | 1.37 | 10.3 | 2.56 | 1.18 | 8.30 |
| G*9V*B12   | HD24                       | 17.1                     | 3.76 | 1.33 | 10.2 | 2.56 | 1.17 | 8.30 |
| G*9V*A12   | UC18A                      | 17.2                     | 3.68 | 1.37 | 10.5 | 2.56 | 1.20 | 8.30 |
| G*9V*B12   | UC18B                      | 17.1                     | 3.72 | 1.35 | 10.3 | 2.62 | 1.15 | 8.30 |
| G*9V*A12   | UC24A                      | 17.3                     | 3.82 | 1.33 | 10.3 | 2.66 | 1.13 | 8.30 |
| G*9V*B12   | UC24B                      | 17.2                     | 3.92 | 1.29 | 10.3 | 2.70 | 1.12 | 8.40 |

1 Rated CFM same as for cooling.

2 Heating MBH based on ARI standards of 70° DB entering indoor air, 72% RH outdoor air with 25 feet of interconnecting piping and no supplemental electric heat operation.

3 Variable speed furnaces have B.O.D (Blower on Delay) standard.

COP equals MBH output divided by (total KW input x 3.412).

HSPF (Heating Seasonal Performance Factor) is the total heating output during a normal annual usage period for heating divided by the total electric power input during the same period.

## HEATING CAPACITY - HC3A024F1With Variable Speed Furnaces

| VARIABLE<br>SPEED<br>FURNACE                               | COIL <sup>1</sup><br>MODEL | ARI HEATING <sup>2</sup> |      |      |      |      |      | HSPF<br>STD |
|--|----------------------------|--------------------------|------|------|------|------|------|-------------|
|  |                            | 47°F                     |      |      | 17°F |      |      |             |
|  |                            | MBH                      | COP  | KW   | MBH  | COP  | KW   |             |
| <b>13 SEER HP WITH VARIABLE SPEED FURNACES<sup>3</sup></b> |                            |                          |      |      |      |      |      |             |
| (F,L)C8V*A12   | FC/MC/PC24A                | 23.2                     | 3.32 | 2.05 | 14.1 | 2.28 | 1.81 | 8.15        |
| FC9V*A12   | FC/MC/PC24A                | 23.2                     | 3.32 | 2.05 | 14.1 | 2.28 | 1.81 | 8.15        |
| FC9(C,V)*B12   | FC/MC/PC24B                | 23.2                     | 3.32 | 2.05 | 14.1 | 2.28 | 1.81 | 8.15        |
| (F,L)C8V*A12   | FC/MC/PC30A                | 23.2                     | 3.34 | 2.03 | 14.1 | 2.28 | 1.81 | 8.20        |
| FC9V*A12   | FC/MC/PC30A                | 23.2                     | 3.32 | 2.05 | 14.1 | 2.28 | 1.81 | 8.15        |
| FC9(C,V)*B12   | FC/MC/PC30B                | 23.2                     | 3.34 | 2.03 | 14.1 | 2.28 | 1.81 | 8.20        |
| (F,L)C8V*A12   | HC30                       | 23.2                     | 3.34 | 2.03 | 14.1 | 2.28 | 1.81 | 8.20        |
| FC9V*A12   | HC30                       | 23.2                     | 3.32 | 2.05 | 14.1 | 2.28 | 1.81 | 8.15        |
| (F,L)C8V*A12   | HD24                       | 23.2                     | 3.34 | 2.03 | 14.1 | 2.28 | 1.81 | 8.20        |
| FC9V*A12   | HD24                       | 23.2                     | 3.32 | 2.05 | 14.1 | 2.28 | 1.81 | 8.15        |
| C*(8,L)C*A12   | FC/MC/PC24A                | 23.2                     | 3.40 | 2.00 | 14.0 | 2.34 | 1.75 | 8.20        |
| C*(8,L)C*B12   | FC/MC/PC24B                | 23.2                     | 3.44 | 1.98 | 13.9 | 2.38 | 1.71 | 8.30        |
| C*9C*B12   | FC/MC/PC24B                | 23.2                     | 3.38 | 2.01 | 14.0 | 2.34 | 1.75 | 8.20        |
| C*(8,L)C*A12   | FC/MC/PC30A                | 23.2                     | 3.40 | 2.00 | 14.0 | 2.34 | 1.75 | 8.20        |
| C*(8,L)C*B12   | FC/MC/PC30B                | 23.2                     | 3.44 | 1.98 | 13.9 | 2.38 | 1.71 | 8.30        |
| C*9C*B12   | FC/MC/PC30B                | 23.2                     | 3.38 | 2.01 | 14.0 | 2.34 | 1.75 | 8.20        |
| C*(8,L)C*A12   | FC/MC/PC32A                | 23.4                     | 3.36 | 2.04 | 13.9 | 2.34 | 1.74 | 8.20        |
| C*(8,L)C*A12   | HC30                       | 23.2                     | 3.28 | 2.07 | 14.0 | 2.28 | 1.80 | 8.20        |
| C*(8,L)C*A12   | HD24                       | 23.2                     | 3.36 | 2.02 | 13.8 | 2.30 | 1.76 | 8.20        |
| C*(8,L)C*B12   | HD24                       | 23.2                     | 3.38 | 2.01 | 13.8 | 2.32 | 1.74 | 8.20        |
| C*9C*B12   | HD24                       | 23.2                     | 3.36 | 2.02 | 13.8 | 2.30 | 1.76 | 8.20        |
| C*(8,L)C*A12   | UC24A                      | 23.4                     | 3.44 | 1.99 | 14.0 | 2.36 | 1.74 | 8.20        |
| C*(8,L)C*B12   | UC24B                      | 23.2                     | 3.48 | 1.95 | 13.9 | 2.40 | 1.70 | 8.30        |
| C*9C*B12   | UC24B                      | 23.4                     | 3.44 | 1.99 | 14.0 | 2.36 | 1.74 | 8.20        |
| C*(8,L)C*A12   | UC30A                      | 23.4                     | 3.44 | 1.99 | 14.0 | 2.36 | 1.74 | 8.20        |
| C*(8,L)C*B12   | UC30B                      | 23.2                     | 3.48 | 1.95 | 13.9 | 2.40 | 1.70 | 8.30        |
| C*9C*B12   | UC30B                      | 23.4                     | 3.44 | 1.99 | 14.0 | 2.36 | 1.74 | 8.20        |
| G*9V*A12   | FC/MC/PC24A                | 23.4                     | 3.36 | 2.04 | 14.2 | 2.30 | 1.81 | 8.20        |
| G*9V*B12   | FC/MC/PC24B                | 23.2                     | 3.38 | 2.01 | 14.0 | 2.34 | 1.75 | 8.20        |
| G*9V*A12   | FC/MC/PC30A                | 23.4                     | 3.36 | 2.04 | 14.2 | 2.30 | 1.81 | 8.20        |
| G*9V*B12   | FC/MC/PC30B                | 23.2                     | 3.38 | 2.01 | 14.0 | 2.34 | 1.75 | 8.20        |
| G*9V*A12   | FC/MC/PC32A                | 23.6                     | 3.34 | 2.07 | 14.1 | 2.30 | 1.80 | 8.10        |
| G*9V*A12   | HC30                       | 23.4                     | 3.30 | 2.08 | 13.9 | 2.28 | 1.79 | 8.20        |
| G*9V*A12   | HD24                       | 23.4                     | 3.30 | 2.08 | 13.9 | 2.26 | 1.80 | 8.20        |
| G*9V*B12   | HD24                       | 23.2                     | 3.36 | 2.02 | 13.8 | 2.30 | 1.76 | 8.20        |
| G*9V*A12   | UC24A                      | 23.4                     | 3.40 | 2.02 | 14.1 | 2.34 | 1.77 | 8.20        |
| G*9V*B12   | UC24B                      | 23.4                     | 3.44 | 1.99 | 14.0 | 2.36 | 1.74 | 8.20        |
| G*9V*A12   | UC30A                      | 23.4                     | 3.40 | 2.02 | 14.1 | 2.34 | 1.77 | 8.20        |
| G*9V*B12   | UC30B                      | 23.4                     | 3.44 | 1.99 | 14.0 | 2.36 | 1.74 | 8.20        |

1 Rated CFM same as for cooling.

2 Heating MBH based on ARI standards of 70° DB entering indoor air, 72% RH outdoor air with 25 feet of interconnecting piping and no supplemental electric heat operation.

3 Variable speed furnaces have B.O.D (Blower on Delay) standard.

COP equals MBH output divided by (total KW input x 3.412).

HSPF (Heating Seasonal Performance Factor) is the total heating output during a normal annual usage period for heating divided by the total electric power input during the same period.

**HEATING CAPACITY - HC3A030F1With Variable Speed Furnaces**

| VARIABLE<br>SPEED<br>FURNACE                               | COIL <sup>1</sup><br>MODEL | ARI HEATING <sup>2</sup> |      |      |      |      |      |      |
|--|----------------------------|--------------------------|------|------|------|------|------|------|
|  |                            | 47°F                     |      |      | 17°F |      |      | HSPF |
|  |                            | MBH                      | COP  | KW   | MBH  | COP  | KW   | STD  |
| <b>13 SEER HP WITH VARIABLE SPEED FURNACES<sup>3</sup></b> |                            |                          |      |      |      |      |      |      |
| (F,L)C8V*B16   | FC/MC/PC35B                | 29.0                     | 3.58 | 2.37 | 17.3 | 2.30 | 2.20 | 8.35 |
| FC9(C,V)*B12   | FC/MC/PC35B                | 29.0                     | 3.60 | 2.36 | 17.2 | 2.30 | 2.19 | 8.35 |
| (F,L)C8V*B16   | HC36                       | 29.4                     | 3.50 | 2.46 | 17.6 | 2.26 | 2.28 | 8.15 |
| FC9(C,V)*B12   | HC36                       | 29.4                     | 3.50 | 2.46 | 17.6 | 2.24 | 2.30 | 8.10 |
| (F,L)C8V*A12   | HD36                       | 29.4                     | 3.50 | 2.46 | 17.6 | 2.26 | 2.28 | 8.15 |
| (F,L)C8V*B16   | HD36                       | 29.0                     | 3.58 | 2.37 | 17.3 | 2.28 | 2.22 | 8.30 |
| (F,L)C8V*C16   | HD36                       | 29.0                     | 3.60 | 2.36 | 17.3 | 2.30 | 2.20 | 8.35 |
| (F,L)C8V*C20   | HD36                       | 29.0                     | 3.60 | 2.36 | 17.2 | 2.30 | 2.19 | 8.35 |
| FC9V*A12   | HD36                       | 29.4                     | 3.50 | 2.46 | 17.6 | 2.24 | 2.30 | 8.10 |
| FC9(C,V)*B12   | HD36                       | 29.2                     | 3.50 | 2.44 | 17.5 | 2.26 | 2.27 | 8.20 |
| FC9(C,V)*C16   | HD36                       | 29.2                     | 3.56 | 2.40 | 17.4 | 2.28 | 2.24 | 8.30 |
| FC9(C,V)*C20   | HD36                       | 29.2                     | 3.56 | 2.40 | 17.4 | 2.28 | 2.24 | 8.30 |
| C*(8,L)C*A12   | FC/MC/PC32A                | 29.8                     | 3.46 | 2.52 | 18.1 | 2.24 | 2.37 | 8.00 |
| C*(8,L)C*B12   | FC/MC/PC35B                | 29.4                     | 3.58 | 2.41 | 17.7 | 2.30 | 2.26 | 8.20 |
| C*9C*B12   | FC/MC/PC35B                | 29.6                     | 3.52 | 2.46 | 17.9 | 2.26 | 2.32 | 8.10 |
| C*(8,L)C*C16   | FC/MC/PC35C                | 29.2                     | 3.60 | 2.38 | 17.7 | 2.32 | 2.24 | 8.20 |
| C*(8,L)C*C20   | FC/MC/PC35C                | 29.4                     | 3.64 | 2.37 | 17.7 | 2.34 | 2.22 | 8.20 |
| C*9C*C16   | FC/MC/PC35C                | 29.2                     | 3.58 | 2.39 | 17.7 | 2.32 | 2.24 | 8.20 |
| C*9C*C20   | FC/MC/PC35C                | 29.2                     | 3.60 | 2.38 | 17.7 | 2.32 | 2.24 | 8.20 |
| C*(8,L)C*A12   | FC/MC/PC37A                | 29.6                     | 3.56 | 2.44 | 17.8 | 2.30 | 2.27 | 8.10 |
| G*9V*A12   | FC/MC/PC30A                | 29.4                     | 3.46 | 2.49 | 17.6 | 2.26 | 2.28 | 8.10 |
| G*9V*A12   | FC/MC/PC32A                | 29.4                     | 3.50 | 2.46 | 17.7 | 2.26 | 2.30 | 8.10 |
| G*9V*B12   | FC/MC/PC35B                | 29.6                     | 3.52 | 2.46 | 17.9 | 2.26 | 2.32 | 8.10 |
| G*9V*C16   | FC/MC/PC35C                | 29.2                     | 3.58 | 2.39 | 17.7 | 2.32 | 2.24 | 8.20 |
| G*9V*C20   | FC/MC/PC35C                | 29.2                     | 3.60 | 2.38 | 17.7 | 2.32 | 2.24 | 8.20 |
| G*9V*A12   | FC/MC/PC37A                | 29.6                     | 3.56 | 2.44 | 17.9 | 2.30 | 2.28 | 8.10 |

1 Rated CFM same as for cooling.

2 Heating MBH based on ARI standards of 70° DB entering indoor air, 72% RH outdoor air with 25 feet of interconnecting piping and no supplemental electric heat operation.

3 Variable speed furnaces have B.O.D (Blower on Delay) standard.

COP equals MBH output divided by (total KW input x 3.412).

HSPF (Heating Seasonal Performance Factor) is the total heating output during a normal annual usage period for heating divided by the total electric power input during the same period.

**HEATING CAPACITY - HC3A036F1With Variable Speed Furnaces**

| VARIABLE<br>SPEED<br>FURNACE                               | COIL <sup>1</sup><br>MODEL | ARI HEATING <sup>2</sup> |      |      |      |      |      |      |
|--|----------------------------|--------------------------|------|------|------|------|------|------|
|  |                            | 47°F                     |      |      | 17°F |      |      | HSPF |
|  |                            | MBH                      | COP  | KW   | MBH  | COP  | KW   | STD  |
| <b>13 SEER HP WITH VARIABLE SPEED FURNACES<sup>3</sup></b> |                            |                          |      |      |      |      |      |      |
| (F,L)C8V*B16   | FC/MC/PC42B                | 34.0                     | 3.60 | 2.64 | 23.0 | 2.68 | 2.58 | 8.40 |
| FC9(C,V)*B12   | FC/MC/PC42B                | 34.0                     | 3.50 | 2.64 | 23.0 | 2.68 | 2.58 | 8.40 |
| (F,L)C8V*C16   | FC/MC/PC42C                | 34.0                     | 3.60 | 2.64 | 23.0 | 2.68 | 2.58 | 8.50 |
| (F,L)C8V*C20   | FC/MC/PC42C                | 34.0                     | 3.50 | 2.64 | 23.0 | 2.68 | 2.58 | 8.50 |
| FC9(C,V)*C16   | FC/MC/PC42C                | 34.0                     | 3.60 | 2.64 | 23.0 | 2.68 | 2.58 | 8.50 |
| FC9(C,V)*C20   | FC/MC/PC42C                | 34.0                     | 3.50 | 2.64 | 23.0 | 2.68 | 2.58 | 8.50 |
| (F,L)C8V*C16   | FC/MC/PC48C                | 35.2                     | 3.90 | 2.64 | 24.0 | 2.72 | 2.58 | 9.50 |
| (F,L)C8V*C20   | FC/MC/PC48C                | 35.2                     | 3.90 | 2.64 | 24.0 | 2.72 | 2.58 | 9.50 |
| FC9(C,V)*C16   | FC/MC/PC48C                | 35.4                     | 3.86 | 2.69 | 24.2 | 2.70 | 2.63 | 9.40 |
| FC9(C,V)*C20   | FC/MC/PC48C                | 35.4                     | 3.86 | 2.69 | 24.2 | 2.70 | 2.63 | 9.50 |
| FC9(C,V)*D20   | FC/MC/PC48D                | 35.4                     | 3.86 | 2.69 | 24.2 | 2.70 | 2.63 | 9.50 |
| (F,L)C8V*C16   | HC42                       | 35.2                     | 3.90 | 2.64 | 24.0 | 2.72 | 2.58 | 9.50 |

For Notes see Page 19.

**HEATING CAPACITY - HC3A036F1With Variable Speed Furnaces (Continued)**

| VARIABLE<br>SPEED<br>FURNACE                               | COIL <sup>1</sup><br>MODEL | ARI HEATING <sup>2</sup> |      |      |      |      |      |      |
|--|----------------------------|--------------------------|------|------|------|------|------|------|
|  |                            | 47°F                     |      |      | 17°F |      |      | HSPF |
|  |                            | MBH                      | COP  | KW   | MBH  | COP  | KW   | STD  |
| <b>13 SEER HP WITH VARIABLE SPEED FURNACES<sup>3</sup></b> |                            |                          |      |      |      |      |      |      |
| (F,L)C8V*C20   | HC42                       | 35.2                     | 3.90 | 2.64 | 24.0 | 2.72 | 2.58 | 9.50 |
| FC9(C,V)*C16   | HC42                       | 35.4                     | 3.86 | 2.69 | 24.2 | 2.70 | 2.63 | 9.40 |
| FC9(C,V)*C20   | HC42                       | 35.4                     | 3.86 | 2.69 | 24.2 | 2.70 | 2.63 | 9.50 |
| (F,L)C8V*C16   | HD48                       | 35.2                     | 3.90 | 2.64 | 24.0 | 2.72 | 2.58 | 9.50 |
| (F,L)C8V*C20   | HD48                       | 35.2                     | 3.90 | 2.64 | 24.0 | 2.72 | 2.58 | 9.50 |
| FC9(C,V)*C16   | HD48                       | 35.4                     | 3.86 | 2.69 | 24.2 | 2.70 | 2.63 | 9.40 |
| FC9(C,V)*C20   | HD48                       | 35.4                     | 3.86 | 2.69 | 24.2 | 2.70 | 2.63 | 9.50 |
| FC9(C,V)*D20   | HD48                       | 35.2                     | 3.86 | 2.67 | 24.0 | 2.70 | 2.60 | 9.50 |
| C*(8,L)C*A12   | FC/MC/PC37A                | 37.2                     | 3.92 | 2.78 | 22.2 | 2.62 | 2.48 | 9.30 |
| C*(8,L)C*B12   | FC/MC/PC43B                | 37.8                     | 4.08 | 2.72 | 22.6 | 2.64 | 2.51 | 9.30 |
| C*9C*B12   | FC/MC/PC43B                | 37.8                     | 4.08 | 2.72 | 22.6 | 2.66 | 2.49 | 9.30 |
| C*(8,L)C*C16   | FC/MC/PC43C                | 37.4                     | 4.20 | 2.61 | 22.2 | 2.72 | 2.39 | 9.40 |
| C*(8,L)C*C20   | FC/MC/PC43C                | 37.2                     | 4.20 | 2.60 | 22.2 | 2.72 | 2.39 | 9.50 |
| C*9C*C16   | FC/MC/PC43C                | 37.6                     | 4.12 | 2.67 | 22.4 | 2.68 | 2.45 | 9.40 |
| C*9C*C20   | FC/MC/PC43C                | 37.4                     | 4.18 | 2.62 | 22.2 | 2.70 | 2.41 | 9.40 |
| C*(8,L)C*C16   | FC/MC/PC48C                | 37.4                     | 4.24 | 2.59 | 22.0 | 2.74 | 2.35 | 9.50 |
| C*(8,L)C*C20   | FC/MC/PC48C                | 37.2                     | 4.28 | 2.55 | 22.0 | 2.76 | 2.34 | 9.50 |
| C*9C*C16   | FC/MC/PC48C                | 37.4                     | 4.20 | 2.61 | 22.2 | 2.72 | 2.39 | 9.40 |
| C*9C*C20   | FC/MC/PC48C                | 37.8                     | 4.24 | 2.61 | 22.4 | 2.70 | 2.43 | 9.40 |
| C*(8,L)C*C16   | HC42                       | 37.4                     | 4.20 | 2.61 | 22.2 | 2.70 | 2.41 | 9.40 |
| C*(8,L)C*C20   | HC42                       | 37.4                     | 4.22 | 2.60 | 22.0 | 2.74 | 2.35 | 9.50 |
| C*9C*C16   | HC42                       | 37.6                     | 4.12 | 2.67 | 22.4 | 2.66 | 2.47 | 9.40 |
| C*9C*C20   | HC42                       | 37.4                     | 4.18 | 2.62 | 22.2 | 2.70 | 2.41 | 9.40 |
| C*(8,L)C*B12   | HD48                       | 37.2                     | 3.78 | 2.88 | 21.8 | 2.44 | 2.62 | 9.20 |
| C*(8,L)C*C16   | HD48                       | 36.8                     | 3.86 | 2.79 | 21.6 | 2.48 | 2.55 | 9.30 |
| C*(8,L)C*C20   | HD48                       | 36.8                     | 3.88 | 2.78 | 21.6 | 2.50 | 2.53 | 9.30 |
| C*9C*B12   | HD48                       | 37.2                     | 3.78 | 2.88 | 22.0 | 2.44 | 2.64 | 9.20 |
| C*9C*C16   | HD48                       | 37.0                     | 3.84 | 2.82 | 21.8 | 2.48 | 2.58 | 9.30 |
| C*9C*C20   | HD48                       | 37.4                     | 3.90 | 2.81 | 22.0 | 2.48 | 2.60 | 9.30 |
| C*(8,L)C*C16   | UC48C                      | 37.4                     | 4.34 | 2.53 | 22.0 | 2.78 | 2.32 | 9.50 |
| C*(8,L)C*C20   | UC48C                      | 37.4                     | 4.38 | 2.50 | 21.8 | 2.82 | 2.27 | 9.50 |
| C*9C*C16   | UC48C                      | 37.6                     | 4.30 | 2.56 | 22.0 | 2.76 | 2.34 | 9.50 |
| C*9C*C20   | UC48C                      | 38.0                     | 4.32 | 2.58 | 22.2 | 2.74 | 2.37 | 9.40 |
| G*9V*A12   | FC/MC/PC37A                | 37.6                     | 3.98 | 2.77 | 22.4 | 2.60 | 2.53 | 9.30 |
| G*9V*B12   | FC/MC/PC43B                | 37.8                     | 4.08 | 2.72 | 22.6 | 2.66 | 2.49 | 9.30 |
| G*9V*C16   | FC/MC/PC43C                | 37.6                     | 4.12 | 2.67 | 22.4 | 2.68 | 2.45 | 9.40 |
| G*9V*C20   | FC/MC/PC43C                | 37.4                     | 4.18 | 2.62 | 22.2 | 2.70 | 2.41 | 9.40 |
| G*9V*C16   | FC/MC/PC48C                | 37.4                     | 4.20 | 2.61 | 22.2 | 2.72 | 2.39 | 9.40 |
| G*9V*C20   | FC/MC/PC48C                | 37.8                     | 4.24 | 2.61 | 22.4 | 2.70 | 2.43 | 9.40 |
| G*9V*C16   | HC42                       | 37.6                     | 4.12 | 2.67 | 22.4 | 2.66 | 2.47 | 9.40 |
| G*9V*C20   | HC42                       | 37.4                     | 4.18 | 2.62 | 22.2 | 2.70 | 2.41 | 9.40 |
| G*9V*B12   | HD48                       | 37.2                     | 3.78 | 2.88 | 22.0 | 2.44 | 2.64 | 9.20 |
| G*9V*C16   | HD48                       | 37.0                     | 3.84 | 2.82 | 21.8 | 2.48 | 2.58 | 9.30 |
| G*9V*C20   | HD48                       | 37.4                     | 3.90 | 2.81 | 22.0 | 2.48 | 2.60 | 9.30 |
| G*9V*C16   | UC48C                      | 37.6                     | 4.30 | 2.56 | 22.0 | 2.76 | 2.34 | 9.50 |
| G*9V*C20   | UC48C                      | 38.0                     | 4.32 | 2.58 | 22.2 | 2.74 | 2.37 | 9.40 |

For Notes see Page 12.

- 1 Rated CFM same as for cooling.
- 2 Heating MBH based on ARI standards of 70° DB entering indoor air, 72% RH outdoor air with 25 feet of interconnecting piping and no supplemental electric heat operation.
- 3 Variable speed furnaces have B.O.D (Blower on Delay) standard.  
COP equals MBH output divided by (total KW input x 3.412).  
HSPF (Heating Seasonal Performance Factor) is the total heating output during a normal annual usage period for heating divided by the total electric power input during the same period.

**HEATING CAPACITY - HC3A042F1With Variable Speed Furnaces**

| VARIABLE<br>SPEED<br>FURNACE                               | COIL <sup>1</sup><br>MODEL | ARI HEATING <sup>2</sup> |      |      |      |      |      |      |
|--|----------------------------|--------------------------|------|------|------|------|------|------|
|  |                            | 47°F                     |      |      | 17°F |      |      | HSPF |
|  |                            | MBH                      | COP  | KW   | MBH  | COP  | KW   | STD  |
| <b>13 SEER HP WITH VARIABLE SPEED FURNACES<sup>3</sup></b> |                            |                          |      |      |      |      |      |      |
| (F,L)C8V*C16   | FC/PC60C                   | 42.0                     | 3.84 | 3.20 | 28.4 | 2.60 | 3.20 | 8.65 |
| (F,L)C8V*C20   | FC/PC60C                   | 42.0                     | 3.86 | 3.19 | 28.4 | 2.60 | 3.20 | 8.70 |
| FC9(C,V)*C16   | FC/PC60C                   | 42.0                     | 3.84 | 3.20 | 28.6 | 2.60 | 3.22 | 8.65 |
| FC9(C,V)*C20   | FC/PC60C                   | 42.0                     | 3.84 | 3.20 | 28.4 | 2.60 | 3.20 | 8.65 |
| FC9(C,V)*D20   | FC/MC/PC60D                | 42.0                     | 3.82 | 3.22 | 28.6 | 2.60 | 3.22 | 8.65 |
| (F,L)C8V*C20   | HC60                       | 42.0                     | 3.86 | 3.19 | 28.4 | 2.60 | 3.20 | 8.70 |
| FC9(C,V)*C20   | HC60                       | 42.0                     | 3.84 | 3.20 | 28.6 | 2.60 | 3.22 | 8.65 |
| FC9(C,V)*D20   | HC60                       | 42.0                     | 3.82 | 3.22 | 28.6 | 2.60 | 3.22 | 8.65 |
| (F,L)C8V*C16   | HD60                       | 42.0                     | 3.84 | 3.20 | 28.4 | 2.60 | 3.20 | 8.65 |
| (F,L)C8V*C20   | HD60                       | 42.0                     | 3.86 | 3.19 | 28.4 | 2.60 | 3.20 | 8.70 |
| FC9(C,V)*C16   | HD60                       | 42.0                     | 3.84 | 3.20 | 28.6 | 2.60 | 3.22 | 8.65 |
| FC9(C,V)*C20   | HD60                       | 42.0                     | 3.84 | 3.20 | 28.4 | 2.60 | 3.20 | 8.65 |
| FC9(C,V)*D20   | HD60                       | 42.0                     | 3.82 | 3.22 | 28.6 | 2.60 | 3.22 | 8.65 |
| C*9C*D20   | FC/MC/PC60D                | 44.5                     | 3.78 | 3.45 | 28.8 | 2.58 | 3.27 | 8.70 |
| C*(8,L)C*C16   | FC/PC60C                   | 44.5                     | 3.78 | 3.45 | 29.0 | 2.58 | 3.29 | 8.70 |
| C*(8,L)C*C20   | FC/PC60C                   | 44.0                     | 3.80 | 3.39 | 29.0 | 2.60 | 3.27 | 8.70 |
| C*9C*C16   | FC/PC60C                   | 44.5                     | 3.70 | 3.52 | 29.2 | 2.54 | 3.37 | 8.60 |
| C*9C*C20   | FC/PC60C                   | 44.5                     | 3.74 | 3.49 | 29.0 | 2.56 | 3.32 | 8.70 |
| C*9C*D20   | FC/MC62D                   | 44.5                     | 3.84 | 3.40 | 28.8 | 2.60 | 3.25 | 8.70 |
| C*(8,L)C*C16   | HC60                       | 44.5                     | 3.90 | 3.34 | 28.8 | 2.64 | 3.20 | 8.80 |
| C*(8,L)C*C20   | HC60                       | 44.5                     | 3.94 | 3.31 | 28.6 | 2.66 | 3.15 | 8.80 |
| C*9C*C16   | HC60                       | 45.0                     | 3.80 | 3.47 | 29.2 | 2.58 | 3.32 | 8.70 |
| C*9C*C20   | HC60                       | 44.5                     | 3.86 | 3.38 | 29.0 | 2.62 | 3.24 | 8.70 |
| C*9C*D20   | HC60                       | 44.5                     | 3.88 | 3.36 | 28.8 | 2.62 | 3.22 | 8.80 |
| C*(8,L)C*C16   | HD60                       | 44.0                     | 3.56 | 3.62 | 28.6 | 2.44 | 3.44 | 8.70 |
| C*(8,L)C*C20   | HD60                       | 44.0                     | 3.60 | 3.58 | 28.4 | 2.48 | 3.36 | 8.70 |
| C*9C*C16   | HD60                       | 44.5                     | 3.50 | 3.73 | 29.0 | 2.40 | 3.54 | 8.60 |
| C*9C*C20   | HD60                       | 44.5                     | 3.54 | 3.68 | 28.8 | 2.42 | 3.49 | 8.60 |
| C*9C*D20   | HD60                       | 44.0                     | 3.56 | 3.62 | 28.6 | 2.44 | 3.44 | 8.60 |
| C*(8,L)C*C16   | UC60C                      | 44.5                     | 3.86 | 3.38 | 28.8 | 2.62 | 3.22 | 8.70 |
| C*(8,L)C*C20   | UC60C                      | 44.5                     | 3.88 | 3.36 | 28.8 | 2.64 | 3.20 | 8.80 |
| C*9C*C16   | UC60C                      | 45.0                     | 3.76 | 3.51 | 29.2 | 2.56 | 3.34 | 8.70 |
| C*9C*C20   | UC60C                      | 44.5                     | 3.82 | 3.41 | 29.0 | 2.58 | 3.29 | 8.70 |
| C*9C*D20   | UC60D                      | 44.5                     | 3.84 | 3.40 | 29.0 | 2.60 | 3.27 | 8.70 |
| G*9V*D20   | FC/MC/PC60D                | 44.5                     | 3.78 | 3.45 | 28.8 | 2.58 | 3.27 | 8.70 |
| G*9V*C16   | FC/PC60C                   | 44.5                     | 3.70 | 3.52 | 29.2 | 2.54 | 3.37 | 8.60 |
| G*9V*C20   | FC/PC60C                   | 44.5                     | 3.74 | 3.49 | 29.0 | 2.56 | 3.32 | 8.70 |
| G*9V*D20   | FC/MC62D                   | 44.5                     | 3.84 | 3.40 | 28.8 | 2.60 | 3.25 | 8.70 |
| G*9V*C16   | HC60                       | 45.0                     | 3.80 | 3.47 | 29.2 | 2.58 | 3.32 | 8.70 |
| G*9V*C20   | HC60                       | 44.5                     | 3.86 | 3.38 | 29.0 | 2.62 | 3.24 | 8.70 |
| G*9V*D20   | HC60                       | 44.5                     | 3.88 | 3.36 | 28.8 | 2.62 | 3.22 | 8.80 |
| G*9V*C16   | HD60                       | 44.5                     | 3.50 | 3.73 | 29.0 | 2.40 | 3.54 | 8.60 |
| G*9V*C20   | HD60                       | 44.5                     | 3.54 | 3.68 | 28.8 | 2.42 | 3.49 | 8.60 |
| G*9V*D20   | HD60                       | 44.0                     | 3.56 | 3.62 | 28.6 | 2.44 | 3.44 | 8.60 |
| G*9V*C16   | UC60C                      | 45.0                     | 3.76 | 3.51 | 29.2 | 2.56 | 3.34 | 8.70 |
| G*9V*C20   | UC60C                      | 44.5                     | 3.82 | 3.41 | 29.0 | 2.58 | 3.29 | 8.70 |
| G*9V*D20   | UC60D                      | 44.5                     | 3.84 | 3.40 | 29.0 | 2.60 | 3.27 | 8.70 |

1 Rated CFM same as for cooling.

2 Heating MBH based on ARI standards of 70° DB entering indoor air, 72% RH outdoor air with 25 feet of interconnecting piping and no supplemental electric heat operation.

3 Variable speed furnaces have B.O.D (Blower on Delay) standard.

COP equals MBH output divided by (total KW input x 3.412).

HSPF (Heating Seasonal Performance Factor) is the total heating output during a normal annual usage period for heating divided by the total electric power input during the same period.

**HEATING CAPACITY - HC3A048F1With Variable Speed Furnaces**

| VARIABLE<br>SPEED<br>FURNACE                               | COIL <sup>1</sup><br>MODEL | ARI HEATING <sup>2</sup> |      |      |      |      |      | HSPF<br>STD |
|--|----------------------------|--------------------------|------|------|------|------|------|-------------|
|  |                            | 47°F                     |      |      | 17°F |      |      |             |
|  |                            | MBH                      | COP  | KW   | MBH  | COP  | KW   |             |
| <b>13 SEER HP WITH VARIABLE SPEED FURNACES<sup>3</sup></b> |                            |                          |      |      |      |      |      |             |
| (F,L)C8V*C16   | FC/PC60C                   | 48.0                     | 3.78 | 3.72 | 33.0 | 2.60 | 3.72 | 8.60        |
| (F,L)C8V*C20   | FC/PC60C                   | 48.0                     | 3.80 | 3.70 | 33.2 | 2.64 | 3.68 | 8.65        |
| FC9(C,V)*C16   | FC/PC60C                   | 48.0                     | 3.76 | 3.74 | 33.4 | 2.60 | 3.76 | 8.60        |
| FC9(C,V)*C20   | FC/PC60C                   | 48.0                     | 3.78 | 3.72 | 33.2 | 2.60 | 3.74 | 8.60        |
| FC9(C,V)*D20   | FC/MC/PC60D                | 48.0                     | 3.80 | 3.70 | 33.2 | 2.64 | 3.68 | 8.65        |
| (F,L)C8V*C20   | HC60                       | 48.0                     | 3.80 | 3.70 | 33.2 | 2.64 | 3.68 | 8.65        |
| FC9(C,V)*C20   | HC60                       | 48.0                     | 3.78 | 3.72 | 33.2 | 2.60 | 3.74 | 8.60        |
| FC9(C,V)*D20   | HC60                       | 48.0                     | 3.80 | 3.70 | 33.2 | 2.64 | 3.68 | 8.65        |
| (F,L)C8V*C16   | HD60                       | 48.0                     | 3.78 | 3.72 | 33.0 | 2.60 | 3.72 | 8.60        |
| (F,L)C8V*C20   | HD60                       | 48.0                     | 3.80 | 3.70 | 33.2 | 2.64 | 3.68 | 8.65        |
| FC9(C,V)*C16   | HD60                       | 48.0                     | 3.76 | 3.74 | 33.4 | 2.60 | 3.76 | 8.60        |
| FC9(C,V)*C20   | HD60                       | 48.0                     | 3.78 | 3.72 | 33.2 | 2.60 | 3.74 | 8.60        |
| FC9(C,V)*D20   | HD60                       | 48.0                     | 3.80 | 3.70 | 33.2 | 2.64 | 3.68 | 8.65        |
| C*9C*D20   | FC/MC/PC60D                | 52.5                     | 3.80 | 4.05 | 33.2 | 2.64 | 3.69 | 8.60        |
| C*9C*D20   | FC/MC62D                   | 52.5                     | 3.90 | 3.95 | 33.0 | 2.64 | 3.66 | 8.60        |
| C*(8,L)C*C16   | FC/PC60C                   | 52.0                     | 3.82 | 3.99 | 33.2 | 2.64 | 3.69 | 8.60        |
| C*(8,L)C*C20   | FC/PC60C                   | 52.0                     | 3.88 | 3.93 | 33.0 | 2.68 | 3.61 | 8.60        |
| C*9C*C16   | FC/PC60C                   | 52.5                     | 3.80 | 4.05 | 33.4 | 2.62 | 3.74 | 8.60        |
| C*9C*C20   | FC/PC60C                   | 52.5                     | 3.80 | 4.05 | 33.4 | 2.62 | 3.74 | 8.60        |
| C*(8,L)C*C16   | HD60                       | 52.0                     | 3.64 | 4.19 | 33.2 | 2.54 | 3.83 | 8.60        |
| C*(8,L)C*C20   | HD60                       | 52.0                     | 3.68 | 4.14 | 33.0 | 2.56 | 3.78 | 8.60        |
| C*9C*C16   | HD60                       | 52.0                     | 3.62 | 4.21 | 33.2 | 2.52 | 3.86 | 8.50        |
| C*9C*C20   | HD60                       | 52.0                     | 3.62 | 4.21 | 33.2 | 2.52 | 3.86 | 8.50        |
| C*9C*D20   | HD60                       | 52.0                     | 3.62 | 4.21 | 33.2 | 2.52 | 3.86 | 8.50        |
| C*(8,L)C*C16   | UC60C                      | 52.5                     | 3.92 | 3.93 | 33.0 | 2.68 | 3.61 | 8.60        |
| C*(8,L)C*C20   | UC60C                      | 52.0                     | 3.96 | 3.85 | 32.8 | 2.72 | 3.53 | 8.60        |
| C*9C*C16   | UC60C                      | 52.5                     | 3.88 | 3.97 | 33.2 | 2.66 | 3.66 | 8.60        |
| C*9C*C20   | UC60C                      | 52.5                     | 3.88 | 3.97 | 33.2 | 2.66 | 3.66 | 8.60        |
| C*9C*D20   | UC60D                      | 52.5                     | 3.88 | 3.97 | 33.0 | 2.66 | 3.64 | 8.60        |
| G*9V*D20   | FC/MC/PC60D                | 52.5                     | 3.80 | 4.05 | 33.2 | 2.64 | 3.69 | 8.60        |
| G*9V*D20   | FC/MC62D                   | 52.5                     | 3.90 | 3.95 | 33.0 | 2.64 | 3.66 | 8.60        |
| G*9V*C16   | FC/PC60C                   | 52.5                     | 3.80 | 4.05 | 33.4 | 2.62 | 3.74 | 8.60        |
| G*9V*C20   | FC/PC60C                   | 52.5                     | 3.80 | 4.05 | 33.4 | 2.62 | 3.74 | 8.60        |
| G*9V*C16   | HD60                       | 52.0                     | 3.62 | 4.21 | 33.2 | 2.52 | 3.86 | 8.50        |
| G*9V*C20   | HD60                       | 52.0                     | 3.62 | 4.21 | 33.2 | 2.52 | 3.86 | 8.50        |
| G*9V*D20   | HD60                       | 52.0                     | 3.62 | 4.21 | 33.2 | 2.52 | 3.86 | 8.50        |
| G*9V*C16   | UC60C                      | 52.5                     | 3.88 | 3.97 | 33.2 | 2.66 | 3.66 | 8.60        |
| G*9V*C20   | UC60C                      | 52.5                     | 3.88 | 3.97 | 33.2 | 2.66 | 3.66 | 8.60        |
| G*9V*D20   | UC60D                      | 52.5                     | 3.88 | 3.97 | 33.0 | 2.66 | 3.64 | 8.60        |

1 Rated CFM same as for cooling.

2 Heating MBH based on ARI standards of 70° DB entering indoor air, 72% RH outdoor air with 25 feet of interconnecting piping and no supplemental electric heat operation.

3 Variable speed furnaces have B.O.D (Blower on Delay) standard.

COP equals MBH output divided by (total KW input x 3.412).

HSPF (Heating Seasonal Performance Factor) is the total heating output during a normal annual usage period for heating divided by the total electric power input during the same period.

**HEATING CAPACITY - HC3A060F1With Variable Speed Furnaces**

| VARIABLE<br>SPEED<br>FURNACE                               | COIL <sup>1</sup><br>MODEL | ARI HEATING <sup>2</sup> |      |      |      |      |      |      |
|--|----------------------------|--------------------------|------|------|------|------|------|------|
|  |                            | 47°F                     |      |      | 17°F |      |      | HSPF |
|  |                            | MBH                      | COP  | KW   | MBH  | COP  | KW   | STD  |
| <b>13 SEER HP WITH VARIABLE SPEED FURNACES<sup>3</sup></b> |                            |                          |      |      |      |      |      |      |
| (F,L)C8V*C20   | FC/PC60C                   | 58.0                     | 3.62 | 4.69 | 39.5 | 2.42 | 4.78 | 8.10 |
| FC9(C,V)*C20   | FC/PC60C                   | 58.0                     | 3.60 | 4.72 | 39.0 | 2.40 | 4.76 | 8.10 |
| FC9(C,V)*D20   | FC/MC/PC60D                | 58.0                     | 3.64 | 4.67 | 39.0 | 2.42 | 4.72 | 8.15 |
| (F,L)C8V*C20   | MC61D                      | 58.0                     | 3.62 | 4.69 | 39.5 | 2.42 | 4.78 | 8.10 |
| FC9(C,V)*C20   | MC61D                      | 58.0                     | 3.60 | 4.72 | 39.0 | 2.40 | 4.76 | 8.10 |
| FC9(C,V)*D20   | MC61D                      | 58.0                     | 3.64 | 4.67 | 39.0 | 2.42 | 4.72 | 8.15 |
| (F,L)C8V*C20   | HC60                       | 58.0                     | 3.62 | 4.69 | 39.5 | 2.42 | 4.78 | 8.10 |
| FC9(C,V)*D20   | HC60                       | 58.0                     | 3.64 | 4.67 | 39.0 | 2.42 | 4.72 | 8.15 |
| (F,L)C8V*C20   | HD60                       | 58.0                     | 3.62 | 4.69 | 39.5 | 2.42 | 4.78 | 8.10 |
| FC9(C,V)*C20   | HD60                       | 58.0                     | 3.60 | 4.72 | 39.0 | 2.40 | 4.76 | 8.10 |
| FC9(C,V)*D20   | HD60                       | 58.0                     | 3.64 | 4.67 | 39.0 | 2.42 | 4.72 | 8.15 |
| C*9C*D20   | FC/MC/PC60D                | 60.0                     | 3.56 | 5.15 | 39.5 | 2.40 | 4.82 | 8.10 |
| C*(8,L)C*C20   | FC/MC62D                   | 60.0                     | 3.54 | 5.42 | 41.0 | 2.38 | 5.05 | 8.70 |
| C*9C*D20   | FC/MC62D                   | 60.0                     | 3.64 | 5.03 | 39.5 | 2.42 | 4.78 | 8.10 |
| C*(8,L)C*C20   | FC/PC60C                   | 60.0                     | 3.58 | 5.08 | 39.0 | 2.42 | 4.72 | 8.10 |
| C*9C*C20   | FC/PC60C                   | 60.0                     | 3.56 | 5.15 | 39.5 | 2.40 | 4.82 | 8.10 |
| C*9C*D20   | HC60                       | 60.0                     | 3.66 | 5.00 | 39.5 | 2.48 | 4.67 | 8.10 |
| C*(8,L)C*C20   | HD60                       | 60.0                     | 3.38 | 5.38 | 39.0 | 2.30 | 4.97 | 8.10 |
| C*9C*C20   | HD60                       | 60.0                     | 3.44 | 5.32 | 39.0 | 2.32 | 4.93 | 8.00 |
| C*9C*D20   | HD60                       | 60.0                     | 3.36 | 5.41 | 39.5 | 2.26 | 5.12 | 8.00 |
| C*(8,L)C*C20   | UC60C                      | 60.0                     | 3.68 | 4.94 | 39.0 | 2.48 | 4.61 | 8.10 |
| C*9C*C20   | UC60C                      | 60.0                     | 3.62 | 5.06 | 39.5 | 2.44 | 4.74 | 8.10 |
| C*9C*D20   | UC60D                      | 60.0                     | 3.64 | 5.03 | 39.5 | 2.46 | 4.71 | 8.10 |
| G*9V*D20   | FC/MC/PC60D                | 60.0                     | 3.56 | 5.15 | 39.5 | 2.40 | 4.82 | 8.10 |
| G*9V*D20   | FC/MC62D                   | 60.0                     | 3.64 | 5.03 | 39.5 | 2.42 | 4.78 | 8.10 |
| G*9V*C20   | FC/PC60C                   | 60.0                     | 3.56 | 5.15 | 39.5 | 2.40 | 4.82 | 8.10 |
| G*9V*D20   | HC60                       | 60.0                     | 3.66 | 5.00 | 39.5 | 2.48 | 4.67 | 8.10 |
| G*9V*C20   | HD60                       | 60.0                     | 3.44 | 5.32 | 39.0 | 2.32 | 4.93 | 8.00 |
| G*9V*D20   | HD60                       | 60.0                     | 3.36 | 5.41 | 39.5 | 2.26 | 5.12 | 8.00 |
| G*9V*C20   | UC60C                      | 60.0                     | 3.62 | 5.06 | 39.5 | 2.44 | 4.74 | 8.10 |
| G*9V*D20   | UC60D                      | 60.0                     | 3.64 | 5.03 | 39.5 | 2.46 | 4.71 | 8.10 |

1 Rated CFM same as for cooling.

2 Heating MBH based on ARI standards of 70° DB entering indoor air, 72% RH outdoor air with 25 feet of interconnecting piping and no supplemental electric heat operation.

3 Variable speed furnaces have B.O.D (Blower on Delay) standard.

COP equals MBH output divided by (total KW input x 3.412).

HSPF (Heating Seasonal Performance Factor) is the total heating output during a normal annual usage period for heating divided by the total electric power input during the same period.

**ACCESSORIES\***

**Hard Start Kit** - Provides increased starting torque for areas with low voltage.

**TXV Kits** - 1TVM2\* series thermal expansion valves precisely meter refrigerant for optimum performance.

**Compressor Discharge Temperature Sensor (2SN02700124)** - Adds an additional safety for improved compressor reliability and diagnostics. Compatible only with 13 SEER and higher heat pumps.

**Bonnet Sensor (373-09243-000)** - The bonnet sensor is used to sense plenum temperature, and is optional with a gas or oil back-up heat source. Compatible only with 13 SEER and higher heat pumps.

**Dehumidistat (2HU16700124)** - Provides increased dehumidification when matched with variable speed furnace or air handler.

**Heat Pump Risers** - (526-35389-000, 526-35390-000, 526-35391-000) - 3", 6", or 12" risers mount easily in composite base pan recesses, ensuring the unit stays clear of snow and ice build-up in harsh winter weather.

**Room Thermostats** - A wide selection of matching thermostats is available to provide features required for any installation.

2H/1C, manual changeover electronic non-programmable thermostat.

3H/2C, non-programmable digital thermostat.

3H/2C, auto/manual changeover, electronic programmable, 7-day, thermostat.

\* For the most current accessory information, refer to the price book or consult factory.

**SOUND POWER RATINGS\***

| UNIT MODEL | (dBA)   |         |
|------------|---------|---------|
|            | Cooling | Heating |
| <b>018</b> | 69      | 71      |
| 024        | 71      | 73      |
| 030        | 72      | 74      |
| 036        | 72      | 72      |
| 042        | 72      | 74      |
| 048        | 73      | 74      |
| 060        | 73      | 74      |

| <b>COOLING PERFORMANCE DATA</b>           |            |                   |      |      |      |      |      |      |      |      |      |      |      |      |      |      |
|---|------------|-------------------|------|------|------|------|------|------|------|------|------|------|------|------|------|------|
| <b>OUTDOOR UNIT MODEL NO.</b>             |            | <b>HC3A018F1</b>  |      |      |      |      |      |      |      |      |      |      |      |      |      |      |
| <b>INDOOR COIL MODEL NO.</b>              |            | <b>FC/MC/PC18</b> |      |      |      |      |      |      |      |      |      |      |      |      |      |      |
| <b>CONDENSER ENTERING AIR TEMPERATURE</b> | ID CFM     | 450               |      |      |      |      | 600  |      |      |      |      | 750  |      |      |      |      |
|   | ID DB (°F) | 80                | 80   | 75   | 80   | 80   | 80   | 80   | 75   | 80   | 80   | 80   | 80   | 75   | 80   | 80   |
|   | ID WB (°F) | 57                | 62   | 62   | 67   | 72   | 57   | 62   | 62   | 67   | 72   | 57   | 62   | 62   | 67   | 72   |
| 65  | T.C.       | 16.1              | 17.1 | 17.1 | 19.0 | 21.4 | 17.8 | 18.3 | 18.1 | 20.0 | 22.1 | 19.5 | 19.4 | 19.1 | 21.1 | 22.8 |
|   | S.C.       | 15.4              | 13.8 | 11.7 | 11.6 | 9.5  | 17.0 | 16.3 | 13.6 | 13.3 | 10.5 | 18.6 | 18.8 | 15.6 | 15.1 | 11.5 |
|   | K.W.       | 0.9               | 0.9  | 0.9  | 0.9  | 0.9  | 0.9  | 0.9  | 0.9  | 0.9  | 0.9  | 0.9  | 0.9  | 0.9  | 0.9  | 0.9  |
| 75  | T.C.       | 15.3              | 16.4 | 16.4 | 18.2 | 20.5 | 17.0 | 17.4 | 17.3 | 19.1 | 21.2 | 18.6 | 18.5 | 18.2 | 20.1 | 21.9 |
|   | S.C.       | 14.8              | 13.3 | 11.3 | 11.3 | 9.2  | 16.4 | 15.6 | 13.1 | 13.0 | 10.2 | 17.9 | 18.0 | 15.0 | 14.7 | 11.2 |
|   | K.W.       | 1.0               | 1.0  | 1.0  | 1.0  | 1.0  | 1.0  | 1.0  | 1.0  | 1.0  | 1.0  | 1.0  | 1.0  | 1.0  | 1.0  | 1.1  |
| 85  | T.C.       | 14.5              | 15.7 | 15.7 | 17.5 | 19.6 | 16.1 | 16.6 | 16.5 | 18.3 | 20.4 | 17.8 | 17.5 | 17.3 | 19.1 | 21.1 |
|   | S.C.       | 14.2              | 12.9 | 10.9 | 11.0 | 8.9  | 15.8 | 15.0 | 12.7 | 12.7 | 9.9  | 17.3 | 17.2 | 14.4 | 14.4 | 10.9 |
|   | K.W.       | 1.1               | 1.1  | 1.1  | 1.2  | 1.2  | 1.1  | 1.2  | 1.1  | 1.2  | 1.2  | 1.2  | 1.2  | 1.2  | 1.2  | 1.2  |
| 95  | T.C.       | 13.6              | 14.9 | 15.0 | 16.8 | 18.7 | 15.3 | 15.8 | 15.7 | 17.4 | 19.5 | 17.0 | 16.6 | 16.4 | 18.0 | 20.3 |
|   | S.C.       | 13.7              | 12.4 | 10.5 | 10.6 | 8.5  | 15.1 | 14.4 | 12.2 | 12.4 | 9.6  | 16.6 | 16.4 | 13.8 | 14.1 | 10.7 |
|   | K.W.       | 1.3               | 1.3  | 1.3  | 1.3  | 1.3  | 1.3  | 1.3  | 1.3  | 1.3  | 1.3  | 1.3  | 1.3  | 1.3  | 1.3  | 1.3  |
| 105                                       | T.C.       | 13.0              | 14.2 | 14.2 | 15.9 | 17.8 | 14.6 | 15.0 | 14.9 | 16.5 | 18.5 | 16.1 | 15.8 | 15.5 | 17.1 | 19.1 |
|   | S.C.       | 13.0              | 11.9 | 10.1 | 10.3 | 8.2  | 14.4 | 13.9 | 11.7 | 11.9 | 9.3  | 15.8 | 15.9 | 13.4 | 13.6 | 10.3 |
|   | K.W.       | 1.4               | 1.4  | 1.4  | 1.4  | 1.5  | 1.4  | 1.4  | 1.4  | 1.5  | 1.5  | 1.4  | 1.5  | 1.4  | 1.5  | 1.5  |
| 115                                       | T.C.       | 12.4              | 13.4 | 13.4 | 15.1 | 16.9 | 13.8 | 14.2 | 14.1 | 15.6 | 17.5 | 15.2 | 15.0 | 14.7 | 16.2 | 18.0 |
|   | S.C.       | 12.4              | 11.5 | 9.7  | 9.9  | 7.9  | 13.7 | 13.4 | 11.3 | 11.5 | 8.9  | 15.1 | 15.4 | 13.0 | 13.2 | 9.9  |
|   | K.W.       | 1.6               | 1.6  | 1.6  | 1.6  | 1.6  | 1.6  | 1.6  | 1.6  | 1.6  | 1.6  | 1.6  | 1.6  | 1.6  | 1.6  | 1.6  |
| 125                                       | T.C.       | 11.8              | 12.7 | 12.7 | 14.3 | 16.0 | 13.1 | 13.4 | 13.3 | 14.8 | 16.5 | 14.3 | 14.2 | 13.9 | 15.3 | 16.9 |
|   | S.C.       | 11.7              | 11.0 | 9.3  | 9.5  | 7.6  | 13.0 | 12.9 | 10.9 | 11.1 | 8.6  | 14.3 | 14.9 | 12.6 | 12.7 | 9.6  |
|   | K.W.       | 1.8               | 1.8  | 1.8  | 1.8  | 1.8  | 1.8  | 1.8  | 1.8  | 1.8  | 1.8  | 1.8  | 1.8  | 1.8  | 1.8  | 1.8  |

**NOTE:** ALL CAPACITIES ARE NET (KBTUH) WITH INDOOR FAN HEAT ALREADY DEDUCTED AT 1250 BTUH/1000 CFM.

### Multipliers for determining the performance with other indoor sections.

**NOTE:** For dry bulb temperatures different than those listed (between 73-87 F), sensible capacity increases by 1060 BTUH per 1000 CFM per degree above the listed temperature and decreases by 1060 BTUH per 1000 CFM per degree below the listed temperature.

| Air Handler | Coil     | T.C. | S.C. | KW   |
|-------------|----------|------|------|------|
| MA08B       | FC/MC18B | 1.00 | 1.00 | 1.00 |
| MV12B       | FC/MC18B | 1.01 | 0.99 | 0.96 |
| AV24        | —        | 1.01 | 0.99 | 0.96 |
| F*FP024     | —        | 1.00 | 1.00 | 1.00 |
| AHP18       | —        | 1.01 | 1.05 | 1.00 |
| —           | HC18     | 1.00 | 1.00 | 1.00 |

| Variable Speed Furnace | Coil        | T.C. | S.C. | KW   |
|------------------------|-------------|------|------|------|
| (F,L)C8V*A12           | FC/MC/PC18A | 1.02 | 1.01 | 0.96 |
| FC9V*A12               | FC/MC/PC18A | 1.02 | 1.01 | 0.96 |
| FC9(C,V)*B12           | FC/MC/PC18B | 1.02 | 1.01 | 0.96 |
| (F,L)C8V*A12           | HC18        | 1.02 | 1.01 | 0.96 |
| FC9V*A12               | HC18        | 1.02 | 1.01 | 0.96 |
| C*(8,L)C*A12           | FC/MC/PC18A | 1.03 | 1.05 | 0.91 |
| C*(8,L)C*B12           | FC/MC/PC18B | 1.02 | 1.02 | 0.90 |
| C*9C*B12               | FC/MC/PC18B | 1.03 | 1.05 | 0.90 |
| C*(8,L)C*A12           | FC/MC/PC24A | 1.04 | 1.09 | 0.94 |
| C*(8,L)C*B12           | FC/MC/PC24B | 1.04 | 1.04 | 0.90 |
| C*9C*B12               | FC/MC/PC24B | 1.04 | 1.09 | 0.93 |
| C*(8,L)C*A12           | HC18        | 1.03 | 1.05 | 0.91 |

| Variable Speed Furnace | Coil        | T.C. | S.C. | KW   |
|------------------------|-------------|------|------|------|
| C*(8,L)C*A12           | HD24        | 1.04 | 1.08 | 0.92 |
| C*(8,L)C*B12           | HD24        | 1.04 | 1.04 | 0.90 |
| C*9C*B12               | HD24        | 1.04 | 1.08 | 0.91 |
| C*(8,L)C*A12           | UC18A       | 1.04 | 1.06 | 0.91 |
| C*(8,L)C*B12           | UC18B       | 1.04 | 1.04 | 0.90 |
| C*9C*B12               | UC18B       | 1.04 | 1.06 | 0.90 |
| C*(8,L)C*A12           | UC24A       | 1.03 | 1.09 | 0.94 |
| C*(8,L)C*B12           | UC24B       | 1.04 | 1.05 | 0.90 |
| C*9C*B12               | UC24B       | 1.04 | 1.10 | 0.93 |
| G*9V*A12               | FC/MC/PC18A | 1.03 | 1.05 | 0.93 |
| G*9V*B12               | FC/MC/PC18B | 1.03 | 1.05 | 0.90 |
| G*9V*A12               | FC/MC/PC24A | 1.04 | 1.07 | 0.93 |
| G*9V*B12               | FC/MC/PC24B | 1.04 | 1.09 | 0.93 |
| G*9V*A12               | HC18        | 1.03 | 1.05 | 0.93 |
| G*9V*A12               | HD24        | 1.04 | 1.06 | 0.93 |
| G*9V*B12               | HD24        | 1.04 | 1.08 | 0.91 |
| G*9V*A12               | UC18A       | 1.04 | 1.06 | 0.93 |
| G*9V*B12               | UC18B       | 1.04 | 1.06 | 0.90 |
| G*9V*A12               | UC24A       | 1.04 | 1.08 | 0.93 |
| G*9V*B12               | UC24B       | 1.04 | 1.10 | 0.93 |

| <b>COOLING PERFORMANCE DATA</b>           |            |                   |      |      |      |      |      |      |      |      |      |      |      |      |      |      |
|---|------------|-------------------|------|------|------|------|------|------|------|------|------|------|------|------|------|------|
| <b>OUTDOOR UNIT MODEL NO.</b>             |            | <b>HC3A024F1</b>  |      |      |      |      |      |      |      |      |      |      |      |      |      |      |
| <b>INDOOR COIL MODEL NO.</b>              |            | <b>FC/MC/PC24</b> |      |      |      |      |      |      |      |      |      |      |      |      |      |      |
| <b>CONDENSER ENTERING AIR TEMPERATURE</b> | ID CFM     | 600               |      |      |      |      | 800  |      |      |      |      | 1000 |      |      |      |      |
|   | ID DB (°F) | 80                | 80   | 75   | 80   | 80   | 80   | 80   | 75   | 80   | 80   | 80   | 80   | 75   | 80   | 80   |
|   | ID WB (°F) | 57                | 62   | 62   | 67   | 72   | 57   | 62   | 62   | 67   | 72   | 57   | 62   | 62   | 67   | 72   |
| 65  | T.C.       | 15.4              | 18.9 | 19.1 | 20.9 | 23.6 | 16.7 | 20.1 | 20.0 | 22.2 | 24.9 | 18.1 | 21.2 | 20.9 | 23.5 | 26.2 |
|   | S.C.       | 15.4              | 15.8 | 13.3 | 13.3 | 10.8 | 16.8 | 18.4 | 15.3 | 15.6 | 12.3 | 18.1 | 21.0 | 17.2 | 17.9 | 13.8 |
|   | K.W.       | 1.5               | 1.6  | 1.5  | 1.6  | 1.6  | 1.6  | 1.6  | 1.6  | 1.6  | 1.6  | 1.6  | 1.6  | 1.6  | 1.6  | 1.6  |
| 75  | T.C.       | 18.3              | 20.8 | 20.9 | 23.4 | 26.4 | 19.9 | 22.0 | 22.1 | 24.5 | 27.7 | 21.4 | 23.3 | 23.3 | 25.6 | 29.0 |
|   | S.C.       | 18.3              | 17.1 | 14.6 | 14.7 | 12.0 | 19.8 | 19.8 | 16.8 | 16.9 | 13.6 | 21.4 | 22.4 | 19.1 | 19.1 | 15.1 |
|   | K.W.       | 1.3               | 1.4  | 1.4  | 1.4  | 1.4  | 1.4  | 1.4  | 1.4  | 1.4  | 1.4  | 1.4  | 1.4  | 1.4  | 1.4  | 1.4  |
| 85  | T.C.       | 16.9              | 19.8 | 20.0 | 22.1 | 25.0 | 18.3 | 21.0 | 21.1 | 23.3 | 26.3 | 19.7 | 22.2 | 22.1 | 24.5 | 27.6 |
|   | S.C.       | 16.8              | 16.5 | 13.9 | 14.0 | 11.4 | 18.3 | 19.1 | 16.1 | 16.2 | 12.9 | 19.8 | 21.7 | 18.2 | 18.5 | 14.4 |
|   | K.W.       | 1.4               | 1.5  | 1.5  | 1.5  | 1.5  | 1.5  | 1.5  | 1.5  | 1.5  | 1.5  | 1.5  | 1.5  | 1.5  | 1.5  | 1.5  |
| 95  | T.C.       | 16.7              | 18.9 | 19.1 | 21.1 | 23.8 | 18.1 | 20.0 | 20.0 | 22.2 | 24.9 | 19.5 | 21.1 | 20.9 | 23.2 | 26.1 |
|   | S.C.       | 16.7              | 16.0 | 13.5 | 13.6 | 11.0 | 18.1 | 18.4 | 15.6 | 15.7 | 12.4 | 19.5 | 20.7 | 17.6 | 17.8 | 13.9 |
|   | K.W.       | 1.7               | 1.7  | 1.7  | 1.8  | 1.8  | 1.7  | 1.7  | 1.7  | 1.8  | 1.8  | 1.7  | 1.7  | 1.7  | 1.8  | 1.8  |
| 105                                       | T.C.       | 16.5              | 18.0 | 18.1 | 20.1 | 22.5 | 17.9 | 19.0 | 19.0 | 21.0 | 23.6 | 19.3 | 20.0 | 19.8 | 21.9 | 24.6 |
|   | S.C.       | 16.5              | 15.5 | 13.1 | 13.1 | 10.5 | 17.9 | 17.6 | 15.1 | 15.2 | 11.9 | 19.2 | 19.7 | 17.0 | 17.2 | 13.3 |
|   | K.W.       | 2.0               | 2.0  | 2.0  | 2.0  | 2.0  | 2.0  | 2.0  | 2.0  | 2.0  | 2.0  | 2.0  | 2.0  | 2.0  | 2.0  | 2.0  |
| 115                                       | T.C.       | 16.4              | 17.1 | 17.2 | 19.1 | 21.3 | 17.7 | 18.0 | 17.9 | 19.9 | 22.3 | 19.0 | 18.9 | 18.6 | 20.6 | 23.2 |
|   | S.C.       | 16.4              | 15.0 | 12.7 | 12.7 | 10.1 | 17.7 | 16.9 | 14.6 | 14.6 | 11.5 | 18.9 | 18.8 | 16.4 | 16.6 | 12.8 |
|   | K.W.       | 2.2               | 2.2  | 2.2  | 2.3  | 2.3  | 2.2  | 2.3  | 2.2  | 2.3  | 2.3  | 2.3  | 2.3  | 2.3  | 2.3  | 2.3  |
| 125                                       | T.C.       | 16.2              | 16.2 | 16.3 | 18.2 | 20.1 | 17.5 | 17.0 | 16.9 | 18.7 | 20.9 | 18.8 | 17.8 | 17.5 | 19.3 | 21.8 |
|   | S.C.       | 16.2              | 14.6 | 12.4 | 12.2 | 9.7  | 17.5 | 16.2 | 14.1 | 14.1 | 11.0 | 18.7 | 17.9 | 15.8 | 16.0 | 12.3 |
|   | K.W.       | 2.5               | 2.5  | 2.5  | 2.5  | 2.5  | 2.5  | 2.5  | 2.5  | 2.5  | 2.5  | 2.5  | 2.5  | 2.5  | 2.5  | 2.5  |

**NOTE:** ALL CAPACITIES ARE NET (KBTUH) WITH INDOOR FAN HEAT ALREADY DEDUCTED AT 1250 BTUH/1000 CFM.

#### Multipliers for determining the performance with other indoor sections.

**NOTE:** For dry bulb temperatures different than those listed (between 73-87 F), sensible capacity increases by 1060 BTUH per 1000 CFM per degree above the listed temperature and decreases by 1060 BTUH per 1000 CFM per degree below the listed temperature.

| <b>Air Handler</b> | <b>Coil</b>   | <b>T.C.</b> | <b>S.C.</b> | <b>KW</b> |
|--------------------|---------------|-------------|-------------|-----------|
| MA08B              | FC/MC24B      | 1.00        | 1.00        | 1.00      |
| MA08B              | FC/MC30B      | 1.00        | 1.00        | 1.00      |
| MV12B              | FC/MC24B      | 1.02        | 1.00        | 0.96      |
| MV12B              | FC/MC30B      | 1.02        | 1.00        | 0.96      |
| AV24               | –             | 1.02        | 1.00        | 0.96      |
| AHP24              | –             | 1.00        | 1.01        | 1.00      |
| –                  | FC/MC/PC/UC30 | 1.00        | 1.00        | 1.00      |
| –                  | HC30          | 1.01        | 1.01        | 1.00      |
| –                  | HD24          | 1.02        | 1.02        | 1.00      |

Continued on Page 26.

| Variable Speed Furnace | Coil        | T.C. | S.C. | KW   |
|------------------------|-------------|------|------|------|
| (F,L)C8V*A12           | FC/MC/PC24A | 1.01 | 1.01 | 0.96 |
| FC9V*A12               | FC/MC/PC24A | 1.01 | 1.01 | 0.96 |
| FC9(C,V)*B12           | FC/MC/PC24B | 1.01 | 1.01 | 0.96 |
| (F,L)C8V*A12           | FC/MC/PC30A | 1.01 | 1.01 | 0.96 |
| FC9V*A12               | FC/MC/PC30A | 1.01 | 1.01 | 0.96 |
| FC9(C,V)*B12           | FC/MC/PC30B | 1.01 | 1.01 | 0.96 |
| (F,L)C8V*A12           | HC30        | 1.03 | 1.02 | 0.96 |
| FC9V*A12               | HC30        | 1.03 | 1.02 | 0.96 |
| (F,L)C8V*A12           | HD24        | 1.03 | 1.04 | 0.96 |
| FC9V*A12               | HD24        | 1.03 | 1.04 | 0.96 |
| C*(8,L)C*A12           | FC/MC/PC24A | 1.02 | 1.03 | 0.93 |
| C*(8,L)C*B12           | FC/MC/PC24B | 1.03 | 1.04 | 0.92 |
| C*9C*B12               | FC/MC/PC24B | 1.02 | 1.02 | 0.93 |
| C*(8,L)C*A12           | FC/MC/PC30A | 1.02 | 1.03 | 0.93 |
| C*(8,L)C*B12           | FC/MC/PC30B | 1.03 | 1.04 | 0.92 |
| C*9C*B12               | FC/MC/PC30B | 1.02 | 1.02 | 0.93 |
| C*(8,L)C*A12           | FC/MC/PC32A | 1.03 | 1.03 | 0.94 |
| C*(8,L)C*A12           | HC30        | 1.02 | 1.01 | 0.93 |
| C*(8,L)C*A12           | HD24        | 1.03 | 1.04 | 0.93 |
| C*(8,L)C*B12           | HD24        | 1.03 | 1.04 | 0.92 |

| Variable Speed Furnace | Coil        | T.C. | S.C. | KW   |
|------------------------|-------------|------|------|------|
| C*9C*B12               | HD24        | 1.03 | 1.04 | 0.93 |
| C*(8,L)C*A12           | UC24A       | 1.02 | 1.04 | 0.93 |
| C*(8,L)C*B12           | UC24B       | 1.03 | 1.04 | 0.92 |
| C*9C*B12               | UC24B       | 1.02 | 1.04 | 0.93 |
| C*(8,L)C*A12           | UC30A       | 1.02 | 1.04 | 0.93 |
| C*(8,L)C*B12           | UC30B       | 1.03 | 1.04 | 0.92 |
| C*9C*B12               | UC30B       | 1.02 | 1.04 | 0.93 |
| G*9V*A12               | FC/MC/PC24A | 1.02 | 1.03 | 0.94 |
| G*9V*B12               | FC/MC/PC24B | 1.02 | 1.02 | 0.93 |
| G*9V*A12               | FC/MC/PC30A | 1.02 | 1.03 | 0.94 |
| G*9V*B12               | FC/MC/PC30B | 1.02 | 1.02 | 0.93 |
| G*9V*A12               | FC/MC/PC32A | 1.03 | 1.04 | 0.96 |
| G*9V*A12               | HC30        | 1.02 | 1.03 | 0.94 |
| G*9V*A12               | HD24        | 1.02 | 1.03 | 0.94 |
| G*9V*B12               | HD24        | 1.03 | 1.04 | 0.93 |
| G*9V*A12               | UC24A       | 1.02 | 1.03 | 0.94 |
| G*9V*B12               | UC24B       | 1.02 | 1.04 | 0.93 |
| G*9V*A12               | UC30A       | 1.02 | 1.03 | 0.94 |
| G*9V*B12               | UC30B       | 1.02 | 1.04 | 0.93 |

| <b>COOLING PERFORMANCE DATA</b>           |            |                  |      |      |      |      |      |      |      |      |      |      |      |      |      |      |
|---|------------|------------------|------|------|------|------|------|------|------|------|------|------|------|------|------|------|
| <b>OUTDOOR UNIT MODEL NO.</b>             |            | <b>HC3A030F1</b> |      |      |      |      |      |      |      |      |      |      |      |      |      |      |
| <b>INDOOR COIL MODEL NO.</b>              |            | <b>AHP30</b>     |      |      |      |      |      |      |      |      |      |      |      |      |      |      |
| <b>CONDENSER ENTERING AIR TEMPERATURE</b> | ID CFM     | 800              |      |      |      |      | 1000 |      |      |      |      | 1200 |      |      |      |      |
|   | ID DB (°F) | 80               | 80   | 75   | 80   | 80   | 80   | 80   | 75   | 80   | 80   | 80   | 80   | 75   | 80   | 80   |
|   | ID WB (°F) | 57               | 62   | 62   | 67   | 72   | 57   | 62   | 62   | 67   | 72   | 57   | 62   | 62   | 67   | 72   |
| 65  | T.C.       | 26.3             | 28.5 | 28.4 | 31.2 | 34.1 | 28.3 | 29.2 | 29.4 | 32.2 | 35.2 | 30.3 | 29.9 | 30.4 | 33.1 | 36.3 |
|   | S.C.       | 25.8             | 23.4 | 19.9 | 19.6 | 15.5 | 27.8 | 26.4 | 22.0 | 21.7 | 16.6 | 29.8 | 29.5 | 24.1 | 23.8 | 17.7 |
|   | K.W.       | 1.5              | 1.5  | 1.5  | 1.5  | 1.6  | 1.5  | 1.5  | 1.5  | 1.5  | 1.6  | 1.5  | 1.5  | 1.5  | 1.6  | 1.6  |
| 75  | T.C.       | 25.7             | 27.4 | 27.5 | 30.1 | 33.0 | 27.4 | 28.2 | 28.4 | 31.0 | 33.9 | 29.2 | 29.1 | 29.3 | 31.9 | 34.8 |
|   | S.C.       | 25.1             | 23.0 | 19.5 | 19.2 | 15.1 | 26.9 | 25.8 | 21.6 | 21.3 | 16.5 | 28.7 | 28.6 | 23.7 | 23.3 | 17.8 |
|   | K.W.       | 1.7              | 1.7  | 1.7  | 1.7  | 1.8  | 1.7  | 1.7  | 1.7  | 1.7  | 1.8  | 1.7  | 1.7  | 1.7  | 1.8  | 1.8  |
| 85  | T.C.       | 25.0             | 26.4 | 26.5 | 29.1 | 31.8 | 26.6 | 27.3 | 27.4 | 29.9 | 32.6 | 28.1 | 28.2 | 28.3 | 30.7 | 33.4 |
|   | S.C.       | 24.5             | 22.6 | 19.1 | 18.8 | 14.7 | 26.1 | 25.2 | 21.2 | 20.8 | 16.3 | 27.7 | 27.8 | 23.3 | 22.8 | 17.9 |
|   | K.W.       | 1.9              | 1.9  | 1.9  | 1.9  | 2.0  | 1.9  | 1.9  | 1.9  | 1.9  | 2.0  | 1.9  | 1.9  | 1.9  | 2.0  | 2.0  |
| 95  | T.C.       | 24.3             | 25.3 | 25.6 | 28.0 | 30.7 | 25.7 | 26.3 | 26.4 | 28.8 | 31.3 | 27.0 | 27.3 | 27.2 | 29.5 | 31.9 |
|   | S.C.       | 23.8             | 22.2 | 18.7 | 18.4 | 14.3 | 25.2 | 24.6 | 20.8 | 20.4 | 16.1 | 26.6 | 27.0 | 22.9 | 22.4 | 18.0 |
|   | K.W.       | 2.1              | 2.1  | 2.1  | 2.1  | 2.1  | 2.1  | 2.1  | 2.1  | 2.1  | 2.2  | 2.1  | 2.2  | 2.1  | 2.2  | 2.2  |
| 105                                       | T.C.       | 22.9             | 24.0 | 24.3 | 26.7 | 29.3 | 24.1 | 25.1 | 25.0 | 27.3 | 29.9 | 25.4 | 26.2 | 25.8 | 28.0 | 30.4 |
|   | S.C.       | 22.5             | 21.7 | 18.2 | 17.9 | 13.8 | 23.7 | 23.7 | 20.3 | 19.9 | 15.5 | 25.0 | 25.8 | 22.4 | 21.8 | 17.1 |
|   | K.W.       | 2.4              | 2.4  | 2.4  | 2.4  | 2.4  | 2.4  | 2.4  | 2.4  | 2.4  | 2.4  | 2.4  | 2.4  | 2.4  | 2.4  | 2.5  |
| 115                                       | T.C.       | 21.6             | 22.7 | 22.9 | 25.3 | 27.9 | 22.7 | 23.9 | 23.7 | 25.9 | 28.5 | 23.8 | 25.0 | 24.4 | 26.5 | 29.0 |
|   | S.C.       | 21.2             | 21.2 | 17.8 | 17.4 | 13.4 | 22.3 | 22.9 | 19.9 | 19.3 | 14.8 | 23.5 | 24.6 | 22.0 | 21.2 | 16.2 |
|   | K.W.       | 2.7              | 2.7  | 2.7  | 2.7  | 2.7  | 2.7  | 2.7  | 2.7  | 2.7  | 2.7  | 2.7  | 2.7  | 2.7  | 2.7  | 2.7  |
| 125                                       | T.C.       | 20.2             | 21.5 | 21.6 | 24.0 | 26.6 | 21.2 | 22.6 | 22.3 | 24.5 | 27.1 | 22.1 | 23.8 | 23.1 | 25.1 | 27.6 |
|   | S.C.       | 19.9             | 20.6 | 17.3 | 16.9 | 13.0 | 20.9 | 22.1 | 19.4 | 18.8 | 14.1 | 22.0 | 23.5 | 21.5 | 20.7 | 15.3 |
|   | K.W.       | 3.0              | 3.0  | 3.0  | 3.0  | 3.0  | 3.0  | 3.0  | 3.0  | 3.0  | 3.0  | 3.0  | 3.0  | 3.0  | 3.0  | 3.0  |

**NOTE:** ALL CAPACITIES ARE NET (KBTUH) WITH INDOOR FAN HEAT ALREADY DEDUCTED AT 1250 BTUH/1000 CFM.

**Multipliers for determining the performance with other indoor sections.**

**NOTE:** For dry bulb temperatures different than those listed (between 73-87 F), sensible capacity increases by 1060 BTUH per 1000 CFM per degree above the listed temperature and decreases by 1060 BTUH per 1000 CFM per degree below the listed temperature.

| Air Handler | Coil       | T.C. | S.C. | KW   |
|-------------|------------|------|------|------|
| MA12B       | FC/MC35B   | 0.99 | 1.00 | 1.00 |
| MA12B       | FC/MC42B   | 0.99 | 1.00 | 1.00 |
| MV12B       | FC/MC35B   | 1.01 | 0.99 | 0.96 |
| MV12B       | FC/MC42B   | 1.01 | 0.99 | 0.96 |
| AV36        | -          | 1.01 | 0.99 | 0.96 |
| F*FP040     | -          | 0.99 | 1.00 | 1.00 |
| -           | FC/MC/PC35 | 0.99 | 1.00 | 1.00 |
| -           | HC36       | 1.00 | 1.00 | 1.00 |
| -           | HD36       | 1.00 | 1.00 | 1.00 |

| Variable Speed Furnace | Coil        | T.C. | S.C. | KW   |
|------------------------|-------------|------|------|------|
| (F,L)C8V*B16           | FC/MC/PC35B | 1.01 | 1.00 | 0.96 |
| FC9(C,V)*B12           | FC/MC/PC35B | 1.01 | 1.00 | 0.96 |
| (F,L)C8V*B16           | HC36        | 1.01 | 1.00 | 0.96 |
| FC9(C,V)*B12           | HC36        | 1.01 | 1.00 | 0.96 |
| (F,L)C8V*A12           | HD36        | 1.01 | 1.00 | 0.96 |
| (F,L)C8V*B16           | HD36        | 1.01 | 1.00 | 0.96 |
| (F,L)C8V*C16           | HD36        | 1.02 | 1.00 | 0.96 |

| Variable Speed Furnace | Coil        | T.C. | S.C. | KW   |
|------------------------|-------------|------|------|------|
| (F,L)C8V*C20           | HD36        | 1.02 | 1.01 | 0.96 |
| FC9V*A12               | HD36        | 1.01 | 1.00 | 1.00 |
| FC9(C,V)*B12           | HD36        | 1.01 | 1.00 | 0.96 |
| FC9(C,V)*C16           | HD36        | 1.01 | 1.00 | 0.96 |
| FC9(C,V)*C20           | HD36        | 1.01 | 1.00 | 0.96 |
| C*(8,L)C*A12           | FC/MC/PC32A | 1.01 | 1.03 | 0.99 |
| C*(8,L)C*B12           | FC/MC/PC35B | 1.02 | 1.04 | 0.95 |
| C*9C*B12               | FC/MC/PC35B | 1.02 | 1.03 | 0.97 |
| C*(8,L)C*C16           | FC/MC/PC35C | 1.02 | 1.04 | 0.93 |
| C*(8,L)C*C20           | FC/MC/PC35C | 1.03 | 1.07 | 0.94 |
| C*9C*C16               | FC/MC/PC35C | 1.02 | 1.04 | 0.94 |
| C*9C*C20               | FC/MC/PC35C | 1.02 | 1.04 | 0.94 |
| C*(8,L)C*A12           | FC/MC/PC37A | 1.02 | 1.02 | 0.97 |
| G*9V*A12               | FC/MC/PC30A | 0.99 | 0.99 | 0.95 |
| G*9V*A12               | FC/MC/PC32A | 1.01 | 1.02 | 0.96 |
| G*9V*B12               | FC/MC/PC35B | 1.02 | 1.03 | 0.97 |
| G*9V*C16               | FC/MC/PC35C | 1.02 | 1.04 | 0.94 |
| G*9V*C20               | FC/MC/PC35C | 1.02 | 1.04 | 0.94 |
| G*9V*A12               | FC/MC/PC37A | 1.02 | 1.03 | 0.97 |

| <b>COOLING PERFORMANCE DATA</b>           |                   |                      |      |      |      |      |             |      |      |      |      |             |      |      |      |      |  |
|---|-------------------|----------------------|------|------|------|------|-------------|------|------|------|------|-------------|------|------|------|------|--|
| <b>OUTDOOR UNIT MODEL NO.</b>             |                   | <b>HC3A036F1</b>     |      |      |      |      |             |      |      |      |      |             |      |      |      |      |  |
| <b>INDOOR COIL MODEL NO.</b>              |                   | <b>FC/MC/PC/UC48</b> |      |      |      |      |             |      |      |      |      |             |      |      |      |      |  |
| <b>CONDENSER ENTERING AIR TEMPERATURE</b> | <b>ID CFM</b>     | <b>1000</b>          |      |      |      |      | <b>1200</b> |      |      |      |      | <b>1400</b> |      |      |      |      |  |
|   | <b>ID DB (°F)</b> | 80                   | 80   | 75   | 80   | 80   | 80          | 80   | 75   | 80   | 80   | 80          | 80   | 75   | 80   | 80   |  |
|   | <b>ID WB (°F)</b> | 57                   | 62   | 62   | 67   | 72   | 57          | 62   | 62   | 67   | 72   | 57          | 62   | 62   | 67   | 72   |  |
| 65  | T.C.              | 33.3                 | 36.9 | 35.5 | 35.8 | 39.2 | 35.5        | 37.4 | 37.8 | 34.5 | 40.7 | 37.6        | 37.9 | 40.1 | 33.2 | 42.3 |  |
|   | S.C.              | 32.7                 | 33.6 | 25.5 | 22.7 | 18.5 | 34.9        | 34.7 | 29.6 | 20.8 | 20.1 | 37.0        | 35.7 | 33.8 | 19.0 | 21.8 |  |
|   | K.W.              | 1.8                  | 1.8  | 1.8  | 1.8  | 1.8  | 1.8         | 1.8  | 1.8  | 1.8  | 1.8  | 1.8         | 1.8  | 1.8  | 1.8  | 1.8  |  |
| 75  | T.C.              | 32.5                 | 35.5 | 33.9 | 34.2 | 37.7 | 34.4        | 36.1 | 35.0 | 33.8 | 39.2 | 36.4        | 36.6 | 36.1 | 33.3 | 40.6 |  |
|   | S.C.              | 31.9                 | 32.9 | 24.9 | 22.1 | 17.8 | 33.9        | 34.0 | 27.2 | 21.6 | 19.5 | 35.9        | 35.0 | 29.4 | 21.1 | 21.1 |  |
|   | K.W.              | 2.0                  | 2.0  | 2.0  | 2.0  | 2.1  | 2.0         | 2.0  | 2.0  | 2.0  | 2.1  | 2.0         | 2.0  | 2.0  | 2.0  | 2.1  |  |
| 85  | T.C.              | 31.6                 | 34.2 | 32.3 | 32.7 | 36.3 | 33.4        | 34.8 | 32.1 | 33.0 | 37.6 | 35.2        | 35.4 | 32.0 | 33.3 | 38.8 |  |
|   | S.C.              | 31.1                 | 32.2 | 24.4 | 21.4 | 17.1 | 33.0        | 33.3 | 24.7 | 22.4 | 18.8 | 34.8        | 34.4 | 25.0 | 23.3 | 20.5 |  |
|   | K.W.              | 2.3                  | 2.3  | 2.3  | 2.3  | 2.3  | 2.3         | 2.3  | 2.3  | 2.3  | 2.3  | 2.3         | 2.3  | 2.3  | 2.3  | 2.3  |  |
| 95  | T.C.              | 30.8                 | 32.8 | 30.7 | 31.2 | 34.9 | 32.4        | 33.4 | 29.3 | 32.3 | 36.0 | 34.0        | 34.1 | 27.9 | 33.3 | 37.1 |  |
|   | S.C.              | 30.3                 | 31.5 | 23.9 | 20.8 | 16.3 | 32.0        | 32.6 | 22.2 | 23.1 | 18.1 | 33.7        | 33.7 | 20.6 | 25.5 | 19.8 |  |
|   | K.W.              | 2.5                  | 2.5  | 2.5  | 2.5  | 2.5  | 2.5         | 2.5  | 2.5  | 2.5  | 2.6  | 2.5         | 2.5  | 2.5  | 2.5  | 2.6  |  |
| 105                                       | T.C.              | 29.2                 | 31.4 | 29.4 | 30.2 | 33.4 | 30.9        | 32.0 | 28.8 | 30.6 | 34.4 | 32.6        | 32.6 | 28.2 | 31.0 | 35.3 |  |
|   | S.C.              | 28.8                 | 30.4 | 23.2 | 21.8 | 16.2 | 30.6        | 31.4 | 22.9 | 22.5 | 17.7 | 32.3        | 32.4 | 22.6 | 23.3 | 19.2 |  |
|   | K.W.              | 2.9                  | 2.9  | 2.9  | 2.9  | 2.9  | 2.9         | 2.9  | 2.9  | 2.9  | 2.9  | 2.9         | 2.9  | 2.9  | 2.9  | 2.9  |  |
| 115                                       | T.C.              | 27.8                 | 30.0 | 28.3 | 29.1 | 31.9 | 29.5        | 30.6 | 28.4 | 29.0 | 32.8 | 31.2        | 31.2 | 28.6 | 28.8 | 33.6 |  |
|   | S.C.              | 27.4                 | 29.4 | 22.6 | 22.8 | 16.1 | 29.1        | 30.3 | 23.6 | 21.9 | 17.3 | 30.9        | 31.2 | 24.6 | 21.1 | 18.6 |  |
|   | K.W.              | 3.2                  | 3.2  | 3.2  | 3.2  | 3.2  | 3.2         | 3.2  | 3.2  | 3.2  | 3.2  | 3.2         | 3.2  | 3.2  | 3.2  | 3.2  |  |
| 125                                       | T.C.              | 26.3                 | 28.7 | 27.1 | 28.1 | 30.4 | 28.1        | 29.3 | 28.0 | 27.4 | 31.2 | 29.9        | 29.9 | 28.9 | 26.6 | 31.9 |  |
|   | S.C.              | 25.9                 | 28.4 | 22.0 | 23.8 | 15.9 | 27.7        | 29.2 | 24.3 | 21.4 | 17.0 | 29.6        | 30.0 | 26.5 | 19.0 | 18.1 |  |
|   | K.W.              | 3.5                  | 3.5  | 3.5  | 3.5  | 3.6  | 3.5         | 3.5  | 3.5  | 3.5  | 3.6  | 3.5         | 3.5  | 3.5  | 3.5  | 3.6  |  |

**NOTE:** ALL CAPACITIES ARE NET (KBTUH) WITH INDOOR FAN HEAT ALREADY DEDUCTED AT 1250 BTUH/1000 CFM.

### Multipliers for determining the performance with other indoor sections

**NOTE:** For dry bulb temperatures different than those listed (between 73-87 F), sensible capacity increases by 1060 BTUH per 1000 CFM per degree above the listed temperature and decreases by 1060 BTUH per 1000 CFM per degree below the listed temperature.

| <b>Air Handler</b> | <b>Coil</b>   | <b>T.C.</b> | <b>S.C.</b> | <b>KW</b> |
|--------------------|---------------|-------------|-------------|-----------|
| MA12B              | FC/MC42B      | 0.98        | 0.98        | 1.00      |
| MA14D              | FC/MC48D      | 1.00        | 1.00        | 1.00      |
| MV16C              | FC/MC48C      | 1.02        | 0.99        | 0.96      |
| MV20D              | FC/MC48D      | 1.02        | 0.99        | 0.96      |
| AV36               | —             | 1.02        | 0.99        | 0.96      |
| AHP42              | —             | 1.00        | 1.00        | 1.00      |
| —                  | FC/MC/PC/UC42 | 0.98        | 0.98        | 1.00      |
| —                  | HC42          | 1.01        | 0.98        | 1.00      |
| —                  | HD48          | 1.02        | 1.02        | 1.00      |

Continued on Page 29.

| Variable Speed Furnace | Coil        | T.C. | S.C. | KW   |
|------------------------|-------------|------|------|------|
| (F,L)C8V*B16           | FC/MC/PC42B | 0.99 | 0.98 | 0.96 |
| FC9(C,V)*B12           | FC/MC/PC42B | 0.99 | 0.98 | 1.00 |
| (F,L)C8V*C16           | FC/MC/PC42C | 0.99 | 0.98 | 1.00 |
| (F,L)C8V*C20           | FC/MC/PC42C | 0.99 | 0.98 | 0.96 |
| FC9(C,V)*C16           | FC/MC/PC42C | 0.99 | 0.98 | 1.00 |
| FC9(C,V)*C20           | FC/MC/PC42C | 0.99 | 0.98 | 0.96 |
| (F,L)C8V*C16           | FC/MC/PC48C | 1.02 | 1.01 | 0.96 |
| (F,L)C8V*C20           | FC/MC/PC48C | 1.02 | 1.01 | 0.96 |
| FC9(C,V)*C16           | FC/MC/PC48C | 1.02 | 1.01 | 0.96 |
| FC9(C,V)*C20           | FC/MC/PC48C | 1.02 | 1.01 | 0.96 |
| FC9(C,V)*D20           | FC/MC/PC48D | 1.02 | 1.01 | 0.96 |
| (F,L)C8V*C16           | HC42        | 1.02 | 1.02 | 0.96 |
| (F,L)C8V*C20           | HC42        | 1.02 | 1.02 | 0.96 |
| FC9(C,V)*C16           | HC42        | 1.02 | 1.02 | 0.96 |
| FC9(C,V)*C20           | HC42        | 1.02 | 1.02 | 0.96 |
| (F,L)C8V*C16           | HD48        | 1.02 | 1.02 | 0.96 |
| (F,L)C8V*C20           | HD48        | 1.02 | 1.02 | 0.96 |
| FC9(C,V)*C16           | HD48        | 1.02 | 1.02 | 0.96 |
| FC9(C,V)*C20           | HD48        | 1.02 | 1.02 | 0.96 |
| FC9(C,V)*D20           | HD48        | 1.02 | 1.01 | 0.96 |
| C*(8,L)C*A12           | FC/MC/PC37A | 0.98 | 0.93 | 0.95 |
| C*(8,L)C*B12           | FC/MC/PC43B | 1.01 | 1.01 | 0.98 |
| C*9C*B12               | FC/MC/PC43B | 1.01 | 1.01 | 0.98 |
| C*(8,L)C*C16           | FC/MC/PC43C | 1.01 | 1.01 | 0.95 |
| C*(8,L)C*C20           | FC/MC/PC43C | 1.01 | 1.01 | 0.94 |
| C*9C*C16               | FC/MC/PC43C | 1.01 | 1.01 | 0.97 |
| C*9C*C20               | FC/MC/PC43C | 1.01 | 1.02 | 0.95 |
| C*(8,L)C*C16           | FC/MC/PC48C | 1.01 | 1.02 | 0.94 |
| C*(8,L)C*C20           | FC/MC/PC48C | 1.01 | 1.02 | 0.93 |

| Variable Speed Furnace | Coil        | T.C. | S.C. | KW   |
|------------------------|-------------|------|------|------|
| C*9C*C16               | FC/MC/PC48C | 1.01 | 1.02 | 0.95 |
| C*9C*C20               | FC/MC/PC48C | 1.01 | 1.05 | 0.97 |
| C*(8,L)C*C16           | HC42        | 1.01 | 1.02 | 0.95 |
| C*(8,L)C*C20           | HC42        | 1.01 | 1.02 | 0.94 |
| C*9C*C16               | HC42        | 1.01 | 1.02 | 0.97 |
| C*9C*C20               | HC42        | 1.01 | 1.02 | 0.95 |
| C*(8,L)C*B12           | HD48        | 1.01 | 1.01 | 0.96 |
| C*(8,L)C*C16           | HD48        | 1.01 | 1.01 | 0.94 |
| C*(8,L)C*C20           | HD48        | 1.01 | 1.01 | 0.93 |
| C*9C*B12               | HD48        | 1.01 | 1.01 | 0.97 |
| C*9C*C16               | HD48        | 1.01 | 1.01 | 0.95 |
| C*9C*C20               | HD48        | 1.01 | 1.04 | 0.97 |
| C*(8,L)C*C16           | UC48C       | 1.01 | 1.02 | 0.94 |
| C*(8,L)C*C20           | UC48C       | 1.01 | 1.02 | 0.93 |
| C*9C*C16               | UC48C       | 1.01 | 1.02 | 0.95 |
| C*9C*C20               | UC48C       | 1.01 | 1.05 | 0.98 |
| G*9V*A12               | FC/MC/PC37A | 0.99 | 0.97 | 0.98 |
| G*9V*B12               | FC/MC/PC43B | 1.01 | 1.01 | 0.98 |
| G*9V*C16               | FC/MC/PC43C | 1.01 | 1.01 | 0.97 |
| G*9V*C20               | FC/MC/PC43C | 1.01 | 1.02 | 0.95 |
| G*9V*C16               | FC/MC/PC48C | 1.01 | 1.02 | 0.95 |
| G*9V*C20               | FC/MC/PC48C | 1.01 | 1.05 | 0.97 |
| G*9V*C16               | HC42        | 1.01 | 1.02 | 0.97 |
| G*9V*C20               | HC42        | 1.01 | 1.02 | 0.95 |
| G*9V*B12               | HD48        | 1.01 | 1.01 | 0.97 |
| G*9V*C16               | HD48        | 1.01 | 1.01 | 0.95 |
| G*9V*C20               | HD48        | 1.01 | 1.04 | 0.97 |
| G*9V*C16               | UC48C       | 1.01 | 1.02 | 0.95 |
| G*9V*C20               | UC48C       | 1.01 | 1.05 | 0.98 |

| <b>COOLING PERFORMANCE DATA</b>                   |            |                   |      |      |      |      |      |      |      |      |      |      |      |      |      |      |
|---|------------|-------------------|------|------|------|------|------|------|------|------|------|------|------|------|------|------|
| <b>OUTDOOR UNIT MODEL NO.</b>                     |            | <b>HC3A042F1</b>  |      |      |      |      |      |      |      |      |      |      |      |      |      |      |
| <b>INDOOR COIL MODEL NO.</b>                      |            | <b>FC/MC/PC60</b> |      |      |      |      |      |      |      |      |      |      |      |      |      |      |
| <b>CONDENSER<br/>ENTERING AIR<br/>TEMPERATURE</b> | ID CFM     | 1200              |      |      |      |      | 1400 |      |      |      |      | 1600 |      |      |      |      |
|   | ID DB (°F) | 80                | 80   | 75   | 80   | 80   | 80   | 80   | 75   | 80   | 80   | 80   | 80   | 75   | 80   | 80   |
|   | ID WB (°F) | 57                | 62   | 62   | 67   | 72   | 57   | 62   | 62   | 67   | 72   | 57   | 62   | 62   | 67   | 72   |
| 65  | T.C.       | 40.3              | 43.7 | 41.4 | 45.8 | 47.2 | 43.9 | 45.1 | 42.2 | 46.7 | 48.5 | 47.6 | 46.6 | 43.0 | 47.6 | 49.7 |
|   | S.C.       | 38.3              | 37.1 | 30.3 | 30.7 | 23.8 | 40.3 | 39.6 | 32.8 | 32.9 | 26.2 | 42.3 | 42.1 | 35.2 | 35.0 | 28.7 |
|   | K.W.       | 2.3               | 2.3  | 2.3  | 2.3  | 2.3  | 2.3  | 2.3  | 2.3  | 2.3  | 2.3  | 2.3  | 2.3  | 2.3  | 2.3  | 2.3  |
| 75  | T.C.       | 38.5              | 42.1 | 40.2 | 44.2 | 45.5 | 42.0 | 43.6 | 41.0 | 45.0 | 46.3 | 45.4 | 45.1 | 41.8 | 45.9 | 47.1 |
|   | S.C.       | 37.2              | 36.3 | 29.8 | 30.0 | 23.0 | 39.1 | 38.7 | 32.2 | 32.3 | 25.1 | 41.0 | 41.0 | 34.6 | 34.5 | 27.1 |
|   | K.W.       | 2.6               | 2.6  | 2.6  | 2.6  | 2.6  | 2.6  | 2.6  | 2.6  | 2.6  | 2.6  | 2.6  | 2.6  | 2.6  | 2.6  | 2.6  |
| 85  | T.C.       | 36.8              | 40.6 | 38.9 | 42.6 | 43.7 | 40.0 | 42.1 | 39.7 | 43.4 | 44.2 | 43.3 | 43.5 | 40.5 | 44.1 | 44.6 |
|   | S.C.       | 36.1              | 35.6 | 29.3 | 29.4 | 22.2 | 37.9 | 37.7 | 31.7 | 31.6 | 23.9 | 39.7 | 39.9 | 34.0 | 33.9 | 25.5 |
|   | K.W.       | 2.9               | 2.9  | 2.9  | 2.9  | 2.9  | 2.9  | 2.9  | 2.9  | 2.9  | 2.9  | 2.9  | 2.9  | 2.9  | 2.9  | 2.9  |
| 95  | T.C.       | 35.1              | 39.0 | 37.6 | 41.1 | 42.0 | 38.1 | 40.5 | 38.5 | 41.7 | 42.0 | 41.1 | 42.0 | 39.3 | 42.3 | 42.1 |
|   | S.C.       | 35.0              | 34.8 | 28.8 | 28.7 | 21.5 | 36.7 | 36.8 | 31.1 | 31.0 | 22.7 | 38.4 | 38.8 | 33.3 | 33.4 | 23.9 |
|   | K.W.       | 3.2               | 3.2  | 3.2  | 3.2  | 3.2  | 3.2  | 3.2  | 3.2  | 3.2  | 3.2  | 3.2  | 3.2  | 3.2  | 3.2  | 3.3  |
| 105   | T.C.       | 34.4              | 37.3 | 35.7 | 38.8 | 39.6 | 37.0 | 38.8 | 36.5 | 39.4 | 39.5 | 39.7 | 40.3 | 37.3 | 40.1 | 39.5 |
|   | S.C.       | 33.6              | 33.4 | 28.0 | 27.8 | 20.7 | 35.1 | 35.2 | 30.2 | 30.1 | 21.8 | 36.6 | 37.0 | 32.4 | 32.5 | 23.0 |
|   | K.W.       | 3.7               | 3.7  | 3.6  | 3.7  | 3.7  | 3.7  | 3.7  | 3.7  | 3.7  | 3.7  | 3.7  | 3.7  | 3.7  | 3.7  | 3.7  |
| 115   | T.C.       | 33.7              | 35.6 | 33.8 | 36.6 | 37.2 | 36.0 | 37.2 | 34.6 | 37.2 | 37.2 | 38.3 | 38.7 | 35.4 | 37.9 | 37.1 |
|   | S.C.       | 32.2              | 32.1 | 27.2 | 26.9 | 20.0 | 33.6 | 33.7 | 29.3 | 29.3 | 21.0 | 34.9 | 35.2 | 31.5 | 31.6 | 22.1 |
|   | K.W.       | 4.1               | 4.1  | 4.1  | 4.1  | 4.1  | 4.1  | 4.1  | 4.1  | 4.1  | 4.1  | 4.1  | 4.1  | 4.1  | 4.1  | 4.1  |
| 125   | T.C.       | 33.0              | 33.9 | 31.9 | 34.4 | 34.9 | 35.0 | 35.5 | 32.7 | 35.1 | 34.8 | 36.9 | 37.1 | 33.4 | 35.7 | 34.6 |
|   | S.C.       | 30.8              | 30.8 | 26.4 | 26.1 | 19.2 | 32.0 | 32.2 | 28.5 | 28.4 | 20.2 | 33.2 | 33.5 | 30.6 | 30.8 | 21.2 |
|   | K.W.       | 4.6               | 4.6  | 4.5  | 4.5  | 4.6  | 4.6  | 4.6  | 4.6  | 4.5  | 4.6  | 4.6  | 4.6  | 4.6  | 4.5  | 4.6  |

**NOTE:** ALL CAPACITIES ARE NET (KBTUH) WITH INDOOR FAN HEAT ALREADY DEDUCTED AT 1250 BTUH/1000 CFM.

### Multipliers for determining the performance with other indoor sections.

**NOTE:** For dry bulb temperatures different than those listed (between 73-87 F), sensible capacity increases by 1060 BTUH per 1000 CFM per degree above the listed temperature and decreases by 1060 BTUH per 1000 CFM per degree below the listed temperature.

| <b>Air Handler</b> | <b>Coil</b> | <b>T.C.</b> | <b>S.C.</b> | <b>KW</b> |
|--------------------|-------------|-------------|-------------|-----------|
| MA14D              | FC/MC60D    | 1.00        | 1.00        | 1.00      |
| MA16C              | FC60C       | 1.00        | 1.00        | 1.00      |
| MV20D              | FC/MC60D    | 1.01        | 0.98        | 0.96      |
| MV16C              | FC60C       | 0.99        | 0.96        | 1.00      |
| AV/SV48            | —           | 1.01        | 0.98        | 0.96      |
| AV/SV60            | —           | 1.01        | 0.98        | 0.96      |
| F*FV060            | —           | 1.01        | 0.98        | 0.96      |
| AHP/SHP48          | —           | 1.00        | 1.00        | 1.00      |
| AHP/SHP60          | —           | 1.01        | 1.00        | 0.96      |
| F*FP045            | —           | 1.00        | 1.00        | 1.00      |
| —                  | HC60        | 1.00        | 1.00        | 1.00      |
| —                  | HD60        | 1.00        | 1.00        | 1.00      |

Continued on Page 31.

| Variable Speed Furnace | Coil        | T.C. | S.C. | KW   |
|------------------------|-------------|------|------|------|
| FC9(C,V)*D20           | FC/MC/PC60D | 1.00 | 1.00 | 1.00 |
| (F,L)C8V*C16           | FC/PC60C    | 1.00 | 1.00 | 1.00 |
| (F,L)C8V*C20           | FC/PC60C    | 1.01 | 1.00 | 1.00 |
| FC9(C,V)*C16           | FC/PC60C    | 1.00 | 1.00 | 1.00 |
| FC9(C,V)*C20           | FC/PC60C    | 1.00 | 1.00 | 1.00 |
| (F,L)C8V*C20           | HC60        | 1.01 | 1.00 | 1.00 |
| FC9(C,V)*C20           | HC60        | 1.00 | 1.00 | 1.00 |
| FC9(C,V)*D20           | HC60        | 1.00 | 1.00 | 1.00 |
| (F,L)C8V*C16           | HD60        | 1.01 | 1.00 | 1.00 |
| (F,L)C8V*C20           | HD60        | 1.01 | 1.00 | 1.00 |
| FC9(C,V)*C16           | HD60        | 1.01 | 1.00 | 1.00 |
| FC9(C,V)*C20           | HD60        | 1.01 | 1.00 | 1.00 |
| FC9(C,V)*D20           | HD60        | 1.00 | 1.00 | 1.00 |
| C*9C*D20               | FC/MC/PC60D | 0.99 | 1.00 | 0.96 |
| C*(8,L)C*C16           | FC/PC60C    | 0.99 | 1.00 | 0.96 |
| C*(8,L)C*C20           | FC/PC60C    | 0.99 | 1.00 | 0.95 |
| C*9C*C16               | FC/PC60C    | 0.99 | 1.00 | 0.99 |
| C*9C*C20               | FC/PC60C    | 0.99 | 1.00 | 0.97 |
| C*9C*D20               | FC/MC62D    | 0.99 | 1.01 | 0.96 |
| C*(8,L)C*C16           | HC60        | 0.99 | 1.00 | 0.96 |
| C*(8,L)C*C20           | HC60        | 0.99 | 1.00 | 0.95 |
| C*9C*C16               | HC60        | 0.99 | 1.00 | 0.99 |
| C*9C*C20               | HC60        | 0.99 | 1.00 | 0.97 |

| Variable Speed Furnace | Coil        | T.C. | S.C. | KW   |
|------------------------|-------------|------|------|------|
| C*9C*D20               | HC60        | 0.99 | 1.00 | 0.96 |
| C*(8,L)C*C16           | HD60        | 0.99 | 1.00 | 0.96 |
| C*(8,L)C*C20           | HD60        | 0.99 | 1.00 | 0.95 |
| C*9C*C16               | HD60        | 0.99 | 1.00 | 0.99 |
| C*9C*C20               | HD60        | 0.99 | 1.00 | 0.97 |
| C*9C*D20               | HD60        | 0.99 | 1.00 | 0.96 |
| C*(8,L)C*C16           | UC60C       | 0.99 | 0.99 | 0.96 |
| C*(8,L)C*C20           | UC60C       | 0.99 | 0.99 | 0.95 |
| C*9C*C16               | UC60C       | 0.99 | 0.99 | 0.99 |
| C*9C*C20               | UC60C       | 0.99 | 0.99 | 0.97 |
| C*9C*D20               | UC60D       | 0.99 | 0.99 | 0.96 |
| G*9V*D20               | FC/MC/PC60D | 0.99 | 1.00 | 0.96 |
| G*9V*C16               | FC/PC60C    | 0.99 | 1.00 | 0.99 |
| G*9V*C20               | FC/PC60C    | 0.99 | 1.00 | 0.97 |
| G*9V*D20               | FC/MC62D    | 0.99 | 1.01 | 0.96 |
| G*9V*C16               | HC60        | 0.99 | 1.00 | 0.99 |
| G*9V*C20               | HC60        | 0.99 | 1.00 | 0.97 |
| G*9V*D20               | HC60        | 0.99 | 1.00 | 0.96 |
| G*9V*C16               | HD60        | 0.99 | 1.00 | 0.99 |
| G*9V*C20               | HD60        | 0.99 | 1.00 | 0.97 |
| G*9V*D20               | HD60        | 0.99 | 1.00 | 0.96 |
| G*9V*C16               | UC60C       | 0.99 | 0.99 | 0.99 |
| G*9V*C20               | UC60C       | 0.99 | 0.99 | 0.97 |
| G*9V*D20               | UC60D       | 0.99 | 0.99 | 0.96 |

| <b>COOLING PERFORMANCE DATA</b>                   |                   |                   |      |      |      |      |             |      |      |      |      |             |      |      |      |      |
|---|-------------------|-------------------|------|------|------|------|-------------|------|------|------|------|-------------|------|------|------|------|
| <b>OUTDOOR UNIT MODEL NO.</b>                     |                   | <b>HC3A048F1</b>  |      |      |      |      |             |      |      |      |      |             |      |      |      |      |
| <b>INDOOR COIL MODEL NO.</b>                      |                   | <b>FC/MC/PC60</b> |      |      |      |      |             |      |      |      |      |             |      |      |      |      |
| <b>CONDENSER<br/>ENTERING AIR<br/>TEMPERATURE</b> | <b>ID CFM</b>     | <b>1400</b>       |      |      |      |      | <b>1600</b> |      |      |      |      | <b>1800</b> |      |      |      |      |
|   | <b>ID DB (°F)</b> | 80                | 80   | 75   | 80   | 80   | 80          | 80   | 75   | 80   | 80   | 80          | 80   | 75   | 80   | 80   |
|   | <b>ID WB (°F)</b> | 57                | 62   | 62   | 67   | 72   | 57          | 62   | 62   | 67   | 72   | 57          | 62   | 62   | 67   | 72   |
| 65  | T.C.              | 43.6              | 47.2 | 46.7 | 50.8 | 55.5 | 46.0        | 48.7 | 47.3 | 51.8 | 55.7 | 48.3        | 50.3 | 47.9 | 52.8 | 55.9 |
|   | S.C.              | 43.2              | 41.1 | 32.8 | 33.4 | 26.3 | 44.9        | 43.8 | 35.5 | 35.5 | 27.2 | 46.6        | 46.5 | 38.2 | 37.7 | 28.2 |
|   | K.W.              | 2.4               | 2.4  | 2.4  | 2.5  | 2.5  | 2.4         | 2.4  | 2.4  | 2.5  | 2.5  | 2.4         | 2.4  | 2.4  | 2.5  | 2.5  |
| 75  | T.C.              | 42.1              | 45.4 | 44.4 | 48.8 | 52.7 | 44.3        | 46.8 | 45.1 | 49.7 | 53.1 | 46.5        | 48.2 | 45.8 | 50.7 | 53.5 |
|   | S.C.              | 41.6              | 40.0 | 32.4 | 32.6 | 25.2 | 43.3        | 42.5 | 34.7 | 34.7 | 26.2 | 44.9        | 44.9 | 37.1 | 36.8 | 27.2 |
|   | K.W.              | 2.8               | 2.8  | 2.8  | 2.8  | 2.9  | 2.8         | 2.8  | 2.8  | 2.8  | 2.9  | 2.8         | 2.8  | 2.8  | 2.8  | 2.9  |
| 85  | T.C.              | 40.5              | 43.7 | 42.1 | 46.8 | 50.0 | 42.6        | 44.9 | 42.9 | 47.7 | 50.5 | 44.8        | 46.1 | 43.8 | 48.5 | 51.1 |
|   | S.C.              | 40.1              | 39.0 | 31.9 | 31.8 | 24.1 | 41.7        | 41.2 | 34.0 | 33.8 | 25.2 | 43.3        | 43.4 | 36.0 | 35.8 | 26.3 |
|   | K.W.              | 3.1               | 3.1  | 3.1  | 3.2  | 3.2  | 3.1         | 3.1  | 3.1  | 3.2  | 3.2  | 3.1         | 3.2  | 3.1  | 3.2  | 3.2  |
| 95  | T.C.              | 39.0              | 41.9 | 39.9 | 44.8 | 47.2 | 41.0        | 42.9 | 40.8 | 45.6 | 47.9 | 43.0        | 44.0 | 41.7 | 46.4 | 48.6 |
|   | S.C.              | 38.5              | 38.0 | 31.5 | 31.0 | 23.0 | 40.0        | 39.9 | 33.2 | 32.9 | 24.2 | 41.6        | 41.8 | 34.9 | 34.9 | 25.3 |
|   | K.W.              | 3.5               | 3.5  | 3.5  | 3.5  | 3.6  | 3.5         | 3.5  | 3.5  | 3.5  | 3.6  | 3.5         | 3.5  | 3.5  | 3.5  | 3.6  |
| 105   | T.C.              | 37.2              | 39.5 | 37.7 | 42.4 | 44.4 | 39.4        | 40.5 | 38.5 | 43.1 | 45.1 | 41.6        | 41.5 | 39.4 | 43.8 | 45.7 |
|   | S.C.              | 36.5              | 36.2 | 30.5 | 30.0 | 22.0 | 38.1        | 37.9 | 32.2 | 31.9 | 23.1 | 39.6        | 39.5 | 33.8 | 33.9 | 24.1 |
|   | K.W.              | 4.0               | 4.0  | 4.0  | 4.0  | 4.1  | 4.0         | 4.0  | 4.0  | 4.0  | 4.1  | 4.0         | 4.0  | 4.0  | 4.0  | 4.1  |
| 115   | T.C.              | 35.5              | 37.3 | 35.6 | 40.1 | 41.8 | 37.9        | 38.1 | 36.4 | 40.7 | 42.3 | 40.2        | 39.0 | 37.1 | 41.4 | 42.8 |
|   | S.C.              | 34.6              | 34.5 | 29.5 | 29.1 | 21.1 | 36.2        | 35.9 | 31.1 | 31.0 | 22.0 | 37.8        | 37.3 | 32.8 | 32.9 | 22.9 |
|   | K.W.              | 4.5               | 4.5  | 4.5  | 4.5  | 4.6  | 4.5         | 4.5  | 4.5  | 4.5  | 4.6  | 4.5         | 4.5  | 4.5  | 4.5  | 4.6  |
| 125   | T.C.              | 33.8              | 35.0 | 33.5 | 37.7 | 39.1 | 36.3        | 35.8 | 34.2 | 38.3 | 39.5 | 38.8        | 36.5 | 34.8 | 38.9 | 39.9 |
|   | S.C.              | 32.7              | 32.8 | 28.5 | 28.2 | 20.2 | 34.3        | 34.0 | 30.1 | 30.0 | 21.0 | 35.9        | 35.1 | 31.7 | 31.9 | 21.7 |
|   | K.W.              | 5.0               | 4.9  | 5.0  | 5.0  | 5.1  | 5.0         | 5.0  | 5.0  | 5.0  | 5.1  | 5.0         | 5.0  | 5.0  | 5.0  | 5.1  |

**NOTE:** ALL CAPACITIES ARE NET (KBTUH) WITH INDOOR FAN HEAT ALREADY DEDUCTED AT 1250 BTUH/1000 CFM.

### Multipliers for determining the performance with other indoor sections.

**NOTE:** For dry bulb temperatures different than those listed (between 73-87 F), sensible capacity increases by 1060 BTUH per 1000 CFM per degree above the listed temperature and decreases by 1060 BTUH per 1000 CFM per degree below the listed temperature.

| <b>Air Handler</b> | <b>Coil</b> | <b>T.C.</b> | <b>S.C.</b> | <b>KW</b> |
|--------------------|-------------|-------------|-------------|-----------|
| MA20D              | FC/MC60D    | 1.00        | 1.00        | 1.00      |
| MA16C              | FC60C       | 1.00        | 1.00        | 1.00      |
| MV20D              | FC/MC60D    | 1.00        | 0.97        | 1.00      |
| MV16C              | FC60C       | 0.98        | 0.96        | 1.00      |
| AV/SV48            | —           | 1.00        | 0.97        | 1.00      |
| AV/SV60            | —           | 1.00        | 0.97        | 1.00      |
| F*FV060            | —           | 1.00        | 0.97        | 1.00      |
| AHP/SHP48          | —           | 1.00        | 1.02        | 1.00      |
| AHP/SHP60          | —           | 1.00        | 1.00        | 1.00      |
| —                  | HC60        | 1.00        | 1.00        | 1.00      |
| —                  | HD60        | 1.00        | 1.00        | 1.00      |

Continued on Page 33.

| Variable Speed Furnace | Coil        | T.C. | S.C. | KW   |
|------------------------|-------------|------|------|------|
| FC9(C,V)*D20           | FC/MC/PC60D | 1.00 | 1.00 | 1.00 |
| (F,L)C8V*C16           | FC/PC60C    | 1.00 | 0.97 | 1.00 |
| (F,L)C8V*C20           | FC/PC60C    | 1.00 | 1.00 | 1.00 |
| FC9(C,V)*C16           | FC/PC60C    | 1.00 | 1.00 | 1.00 |
| FC9(C,V)*C20           | FC/PC60C    | 1.00 | 1.00 | 1.00 |
| (F,L)C8V*C20           | HC60        | 1.00 | 1.00 | 1.00 |
| FC9(C,V)*C20           | HC60        | 1.00 | 1.00 | 1.00 |
| FC9(C,V)*D20           | HC60        | 1.00 | 1.00 | 1.00 |
| (F,L)C8V*C16           | HD60        | 1.00 | 0.97 | 1.00 |
| (F,L)C8V*C20           | HD60        | 1.00 | 1.01 | 1.00 |
| FC9(C,V)*C16           | HD60        | 1.00 | 1.01 | 1.00 |
| FC9(C,V)*C20           | HD60        | 1.00 | 1.01 | 1.00 |
| FC9(C,V)*D20           | HD60        | 1.00 | 1.01 | 1.00 |
| C*9C*D20               | FC/MC/PC60D | 1.01 | 1.01 | 0.99 |
| C*9C*D20               | FC/MC62D    | 1.01 | 1.02 | 0.98 |
| C*(8,L)C*C16           | FC/PC60C    | 1.01 | 1.01 | 0.98 |
| C*(8,L)C*C20           | FC/PC60C    | 1.01 | 1.01 | 0.96 |
| C*9C*C16               | FC/PC60C    | 1.01 | 1.01 | 0.99 |
| C*9C*C20               | FC/PC60C    | 1.01 | 1.01 | 0.99 |
| C*(8,L)C*C16           | HD60        | 0.99 | 1.01 | 0.98 |

| Variable Speed Furnace | Coil        | T.C. | S.C. | KW   |
|------------------------|-------------|------|------|------|
| C*(8,L)C*C20           | HD60        | 0.99 | 1.01 | 0.96 |
| C*9C*C16               | HD60        | 0.99 | 1.00 | 0.99 |
| C*9C*C20               | HD60        | 0.99 | 1.00 | 0.99 |
| C*9C*D20               | HD60        | 0.99 | 1.00 | 0.98 |
| C*(8,L)C*C16           | UC60C       | 1.00 | 1.00 | 0.98 |
| C*(8,L)C*C20           | UC60C       | 1.01 | 1.00 | 0.96 |
| C*9C*C16               | UC60C       | 1.00 | 0.99 | 0.99 |
| C*9C*C20               | UC60C       | 1.00 | 0.99 | 0.99 |
| C*9C*D20               | UC60D       | 1.00 | 0.99 | 0.98 |
| G*9V*D20               | FC/MC/PC60D | 1.01 | 1.01 | 0.99 |
| G*9V*D20               | FC/MC62D    | 1.01 | 1.02 | 0.98 |
| G*9V*C16               | FC/PC60C    | 1.01 | 1.01 | 0.99 |
| G*9V*C20               | FC/PC60C    | 1.01 | 1.01 | 0.99 |
| G*9V*C16               | HD60        | 0.99 | 1.00 | 0.99 |
| G*9V*C20               | HD60        | 0.99 | 1.00 | 0.99 |
| G*9V*D20               | HD60        | 0.99 | 1.00 | 0.98 |
| G*9V*C16               | UC60C       | 1.00 | 0.99 | 0.99 |
| G*9V*C20               | UC60C       | 1.00 | 0.99 | 0.99 |
| G*9V*D20               | UC60D       | 1.00 | 0.99 | 0.98 |

| <b>COOLING PERFORMANCE DATA</b>           |            |                   |      |      |      |      |      |      |      |      |      |      |      |      |      |      |
|---|------------|-------------------|------|------|------|------|------|------|------|------|------|------|------|------|------|------|
| <b>OUTDOOR UNIT MODEL NO.</b>             |            | <b>HC3A060F1</b>  |      |      |      |      |      |      |      |      |      |      |      |      |      |      |
| <b>INDOOR COIL MODEL NO.</b>              |            | <b>FC/MC/PC60</b> |      |      |      |      |      |      |      |      |      |      |      |      |      |      |
| <b>CONDENSER ENTERING AIR TEMPERATURE</b> | ID CFM     | 1600              |      |      |      |      | 1800 |      |      |      |      | 2000 |      |      |      |      |
|   | ID DB (°F) | 80                | 80   | 75   | 80   | 80   | 80   | 80   | 75   | 80   | 80   | 80   | 80   | 75   | 80   | 80   |
|   | ID WB (°F) | 57                | 62   | 62   | 67   | 72   | 57   | 62   | 62   | 67   | 72   | 57   | 62   | 62   | 67   | 72   |
| 65  | T.C.       | 54.0              | 55.2 | 55.2 | 60.7 | 64.4 | 56.4 | 57.0 | 56.5 | 62.3 | 65.6 | 58.7 | 58.7 | 57.7 | 63.9 | 66.7 |
|   | S.C.       | 49.8              | 47.0 | 36.8 | 39.6 | 29.4 | 52.1 | 50.2 | 40.6 | 42.1 | 30.8 | 54.4 | 53.5 | 44.3 | 44.6 | 32.2 |
|   | K.W.       | 2.9               | 2.9  | 3.0  | 3.0  | 3.1  | 3.0  | 2.9  | 3.0  | 3.0  | 3.1  | 3.0  | 2.9  | 3.0  | 3.0  | 3.1  |
| 75  | T.C.       | 52.5              | 53.5 | 52.6 | 58.5 | 61.5 | 54.7 | 55.3 | 53.9 | 60.0 | 62.9 | 57.0 | 57.1 | 55.2 | 61.5 | 64.2 |
|   | S.C.       | 48.2              | 45.9 | 36.6 | 38.4 | 28.4 | 50.4 | 49.1 | 39.9 | 41.0 | 30.0 | 52.6 | 52.2 | 43.3 | 43.5 | 31.6 |
|   | K.W.       | 3.3               | 3.4  | 3.4  | 3.4  | 3.5  | 3.4  | 3.4  | 3.4  | 3.5  | 3.5  | 3.4  | 3.4  | 3.4  | 3.5  | 3.5  |
| 85  | T.C.       | 50.9              | 51.8 | 50.1 | 56.2 | 58.7 | 53.0 | 53.7 | 51.4 | 57.6 | 60.2 | 55.2 | 55.5 | 52.7 | 59.1 | 61.7 |
|   | S.C.       | 46.7              | 44.9 | 36.3 | 37.3 | 27.5 | 48.7 | 47.9 | 39.3 | 39.8 | 29.2 | 50.8 | 50.9 | 42.3 | 42.4 | 31.0 |
|   | K.W.       | 3.7               | 3.8  | 3.8  | 3.9  | 3.9  | 3.8  | 3.8  | 3.8  | 3.9  | 4.0  | 3.8  | 3.8  | 3.9  | 3.9  | 4.0  |
| 95  | T.C.       | 49.3              | 50.2 | 47.6 | 53.9 | 55.8 | 51.4 | 52.0 | 48.9 | 55.3 | 57.5 | 53.4 | 53.8 | 50.2 | 56.6 | 59.2 |
|   | S.C.       | 45.1              | 43.9 | 36.0 | 36.1 | 26.6 | 47.1 | 46.8 | 38.7 | 38.7 | 28.5 | 49.0 | 49.6 | 41.3 | 41.2 | 30.4 |
|   | K.W.       | 4.2               | 4.3  | 4.3  | 4.3  | 4.4  | 4.2  | 4.3  | 4.3  | 4.3  | 4.4  | 4.2  | 4.3  | 4.3  | 4.3  | 4.4  |
| 105                                       | T.C.       | 46.9              | 47.7 | 44.9 | 51.1 | 52.9 | 49.0 | 49.3 | 46.2 | 52.3 | 54.3 | 51.0 | 50.9 | 47.5 | 53.6 | 55.8 |
|   | S.C.       | 42.8              | 42.0 | 34.8 | 34.7 | 25.5 | 44.7 | 44.5 | 37.3 | 37.2 | 27.3 | 46.6 | 46.9 | 39.8 | 39.8 | 29.2 |
|   | K.W.       | 4.8               | 4.9  | 4.9  | 4.9  | 5.0  | 4.8  | 4.9  | 4.9  | 4.9  | 5.0  | 4.8  | 4.9  | 4.9  | 5.0  | 5.0  |
| 115                                       | T.C.       | 44.6              | 45.2 | 42.3 | 48.3 | 50.0 | 46.6 | 46.7 | 43.6 | 49.5 | 51.3 | 48.6 | 48.1 | 44.8 | 50.6 | 52.5 |
|   | S.C.       | 40.7              | 40.2 | 33.5 | 33.3 | 24.5 | 42.4 | 42.2 | 35.9 | 35.8 | 26.2 | 44.2 | 44.2 | 38.3 | 38.3 | 28.0 |
|   | K.W.       | 5.3               | 5.5  | 5.5  | 5.5  | 5.6  | 5.4  | 5.5  | 5.5  | 5.5  | 5.6  | 5.4  | 5.5  | 5.5  | 5.6  | 5.6  |
| 125                                       | T.C.       | 42.3              | 42.8 | 39.7 | 45.6 | 47.2 | 44.2 | 44.0 | 40.9 | 46.6 | 48.2 | 46.2 | 45.3 | 42.2 | 47.6 | 49.3 |
|   | S.C.       | 38.5              | 38.5 | 32.3 | 32.0 | 23.4 | 40.1 | 40.0 | 34.5 | 34.4 | 25.1 | 41.8 | 41.5 | 36.8 | 36.9 | 26.8 |
|   | K.W.       | 5.9               | 6.0  | 6.1  | 6.1  | 6.2  | 6.0  | 6.1  | 6.1  | 6.1  | 6.2  | 6.0  | 6.1  | 6.1  | 6.2  | 6.2  |

**NOTE:** ALL CAPACITIES ARE NET (KBTUH) WITH INDOOR FAN HEAT ALREADY DEDUCTED AT 1250 BTUH/1000 CFM.

### Multipliers for determining the performance with other indoor sections.

**NOTE:** For dry bulb temperatures different than those listed (between 73-87 F), sensible capacity increases by 1060 BTUH per 1000 CFM per degree above the listed temperature and decreases by 1060 BTUH per 1000 CFM per degree below the listed temperature.

| Air Handler | Coil     | T.C. | S.C. | KW   |
|-------------|----------|------|------|------|
| MA20D       | FC/MC60D | 1.00 | 1.00 | 1.00 |
| MA20D       | MC61D    | 1.01 | 1.01 | 1.00 |
| MV20D       | FC/MC60D | 1.00 | 0.98 | 1.00 |
| MV20D       | MC61D    | 1.01 | 0.99 | 1.00 |
| AV/SV60     | –        | 1.00 | 0.98 | 1.00 |
| F*FV060     | –        | 1.00 | 0.98 | 1.00 |
| AHP/SHP60   | –        | 1.00 | 1.02 | 1.00 |
| –           | HC60     | 1.00 | 1.00 | 1.00 |
| –           | HD60     | 1.00 | 1.01 | 1.00 |
| –           | MC61     | 1.01 | 1.01 | 1.00 |

| Variable Speed Furnace | Coil        | T.C. | S.C. | KW   |
|------------------------|-------------|------|------|------|
| FC9(C,V)*D20           | FC/MC/PC60D | 0.99 | 0.95 | 1.00 |
| (F,L)C8V*C20           | FC/PC60C    | 1.00 | 0.99 | 1.00 |
| FC9(C,V)*C20           | FC/PC60C    | 0.99 | 0.95 | 1.00 |
| (F,L)C8V*C20           | HC60        | 1.00 | 0.99 | 1.00 |
| FC9(C,V)*D20           | HC60        | 0.99 | 0.95 | 1.00 |
| (F,L)C8V*C20           | HD60        | 1.00 | 0.99 | 1.00 |
| FC9(C,V)*C20           | HD60        | 0.99 | 0.96 | 1.00 |
| FC9(C,V)*D20           | HD60        | 0.98 | 0.96 | 1.00 |
| (F,L)C8V*C20           | MC61D       | 1.01 | 1.00 | 1.00 |
| FC9(C,V)*C20           | MC61D       | 0.98 | 0.96 | 1.00 |

| Variable Speed Furnace | Coil        | T.C. | S.C. | KW   |
|------------------------|-------------|------|------|------|
| FC9(C,V)*D20           | MC61D       | 1.00 | 0.97 | 1.00 |
| C*9C*D20               | FC/MC/PC60D | 0.99 | 0.96 | 0.97 |
| C*(8,L)C*C20           | FC/MC62D    | 1.00 | 0.98 | 0.96 |
| C*9C*D20               | FC/MC62D    | 0.99 | 0.97 | 0.97 |
| C*(8,L)C*C20           | FC/PC60C    | 1.00 | 0.97 | 0.95 |
| C*9C*C20               | FC/PC60C    | 1.00 | 0.97 | 0.97 |
| C*9C*D20               | HC60        | 1.00 | 0.96 | 0.97 |
| C*(8,L)C*C20           | HD60        | 0.97 | 0.95 | 0.95 |
| C*9C*C20               | HD60        | 0.99 | 0.98 | 0.97 |
| C*9C*D20               | HD60        | 0.96 | 0.95 | 0.97 |
| C*(8,L)C*C20           | UC60C       | 0.99 | 0.95 | 0.95 |
| C*9C*C20               | UC60C       | 0.98 | 0.94 | 0.97 |
| C*9C*D20               | UC60D       | 0.98 | 0.94 | 0.97 |
| G*9V*D20               | FC/MC/PC60D | 0.99 | 0.96 | 0.97 |
| G*9V*D20               | FC/MC62D    | 0.99 | 0.97 | 0.97 |
| G*9V*C20               | FC/PC60C    | 1.00 | 0.97 | 0.97 |
| G*9V*D20               | HC60        | 1.00 | 0.96 | 0.97 |
| G*9V*C20               | HD60        | 0.99 | 0.98 | 0.97 |
| G*9V*D20               | HD60        | 0.96 | 0.95 | 0.97 |
| G*9V*C20               | UC60C       | 0.98 | 0.94 | 0.97 |
| G*9V*D20               | UC60D       | 0.98 | 0.94 | 0.97 |

| HEATING PERFORMANCE DATA                 |   |            |     |        |       |     |        |       |     |        |
|--|---|------------|-----|--------|-------|-----|--------|-------|-----|--------|
| OUTDOOR UNIT MODEL NO.                   |   | HC3A018F1  |     |        |       |     |        |       |     |        |
| INDOOR COIL MODEL NO.                    |   | FC/MC/PC18 |     |        |       |     |        |       |     |        |
| AIR TEMP.<br>ENTERING<br>OUTDOOR<br>UNIT | AIR TEMP.<br>ENTERING<br>INDOOR<br>COIL | ID CFM     |     |        |       |     |        |       |     |        |
|  |   | 450        |     |        | 600   |     |        | 750   |     |        |
|  |   | MBTUH      | KW  | C.O.P. | MBTUH | KW  | C.O.P. | MBTUH | KW  | C.O.P. |
| 60                                       | 60                                      | 20.3       | 1.5 | 4.0    | 21.2  | 1.5 | 4.3    | 22.1  | 1.4 | 4.6    |
|  | 70                                      | 19.6       | 1.6 | 3.5    | 20.6  | 1.6 | 3.8    | 21.6  | 1.5 | 4.2    |
|  | 80                                      | 18.8       | 1.8 | 3.1    | 20.0  | 1.7 | 3.4    | 21.1  | 1.7 | 3.7    |
| 47                                       | 60                                      | 17.4       | 1.4 | 3.6    | 18.0  | 1.4 | 3.8    | 18.6  | 1.4 | 4.0    |
|  | 70                                      | 16.8       | 1.5 | 3.2    | 17.4  | 1.5 | 3.4    | 18.1  | 1.5 | 3.6    |
|  | 80                                      | 16.1       | 1.7 | 2.8    | 16.9  | 1.6 | 3.0    | 17.6  | 1.6 | 3.3    |
| 40                                       | 60                                      | 15.4       | 1.4 | 3.3    | 15.9  | 1.3 | 3.5    | 16.5  | 1.3 | 3.6    |
|  | 70                                      | 15.1       | 1.5 | 3.0    | 15.6  | 1.5 | 3.1    | 16.2  | 1.4 | 3.3    |
|  | 80                                      | 14.7       | 1.6 | 2.6    | 15.3  | 1.6 | 2.8    | 16.0  | 1.6 | 3.0    |
| 30                                       | 60                                      | 12.0       | 1.5 | 2.3    | 12.5  | 1.5 | 2.4    | 13.1  | 1.5 | 2.5    |
|  | 70                                      | 12.5       | 1.4 | 2.6    | 12.9  | 1.4 | 2.7    | 13.2  | 1.4 | 2.7    |
|  | 80                                      | 13.1       | 1.3 | 3.0    | 13.2  | 1.3 | 3.0    | 13.2  | 1.3 | 3.0    |
| 17                                       | 60                                      | 9.5        | 1.4 | 1.9    | 10.7  | 1.4 | 2.3    | 12.0  | 1.3 | 2.7    |
|  | 70                                      | 9.7        | 1.3 | 2.1    | 10.7  | 1.3 | 2.4    | 11.7  | 1.3 | 2.7    |
|  | 80                                      | 10.0       | 1.2 | 2.4    | 10.7  | 1.3 | 2.5    | 11.4  | 1.3 | 2.6    |
| 10                                       | 60                                      | 8.6        | 1.4 | 1.8    | 9.1   | 1.4 | 1.9    | 9.7   | 1.4 | 2.0    |
|  | 70                                      | 9.2        | 1.3 | 2.1    | 9.6   | 1.3 | 2.2    | 10.0  | 1.3 | 2.2    |
|  | 80                                      | 9.9        | 1.2 | 2.4    | 10.1  | 1.2 | 2.4    | 10.4  | 1.2 | 2.4    |

**NOTE:** ALL CAPACITIES INCLUDE INDOOR FAN HEAT AT 1250 BTUH/1000 CFM.

#### Multipliers for determining the performance with other indoor section.

| Air Handler | Coil     | MBH  | KW   | COP  |
|-------------|----------|------|------|------|
| MA08B       | FC/MC18B | 1.00 | 1.00 | 1.00 |
| MV12B       | FC/MC18B | 0.98 | 1.06 | 0.92 |
| AV24        | –        | 0.98 | 1.06 | 0.92 |
| F*FP024     | –        | 1.00 | 1.00 | 1.00 |
| AHP18       | –        | 1.00 | 1.00 | 1.00 |
| –           | HC18     | 1.00 | 1.00 | 1.00 |

| Variable Speed Furnace | Coil        | MBH  | KW   | COP  |
|------------------------|-------------|------|------|------|
| (F,L)C8V*A12           | FC/MC/PC18A | 0.97 | 1.07 | 0.91 |
| FC9V*A12               | FC/MC/PC18A | 0.98 | 1.05 | 0.93 |
| FC9(C,V)*B12           | FC/MC/PC18B | 0.97 | 1.06 | 0.91 |
| (F,L)C8V*A12           | HC18        | 0.97 | 1.07 | 0.91 |
| FC9V*A12               | HC18        | 0.98 | 1.05 | 0.93 |
| C*(8,L)C*A12           | FC/MC/PC18A | 0.98 | 1.08 | 0.91 |
| C*(8,L)C*B12           | FC/MC/PC18B | 0.97 | 1.06 | 0.91 |
| C*9C*B12               | FC/MC/PC18B | 0.97 | 1.08 | 0.90 |
| C*(8,L)C*A12           | FC/MC/PC24A | 0.98 | 1.13 | 0.87 |
| C*(8,L)C*B12           | FC/MC/PC24B | 0.97 | 1.12 | 0.87 |
| C*9C*B12               | FC/MC/PC24B | 0.98 | 1.14 | 0.86 |
| C*(8,L)C*A12           | HC18        | 0.98 | 1.08 | 0.91 |

| Variable Speed Furnace | Coil        | MBH  | KW   | COP  |
|------------------------|-------------|------|------|------|
| C*(8,L)C*A12           | HD24        | 0.98 | 1.10 | 0.89 |
| C*(8,L)C*B12           | HD24        | 0.97 | 1.07 | 0.90 |
| C*9C*B12               | HD24        | 0.98 | 1.11 | 0.89 |
| C*(8,L)C*A12           | UC18A       | 0.98 | 1.09 | 0.90 |
| C*(8,L)C*B12           | UC18B       | 0.97 | 1.08 | 0.90 |
| C*9C*B12               | UC18B       | 0.97 | 1.09 | 0.89 |
| C*(8,L)C*A12           | UC24A       | 0.98 | 1.14 | 0.86 |
| C*(8,L)C*B12           | UC24B       | 0.98 | 1.13 | 0.87 |
| C*9C*B12               | UC24B       | 0.98 | 1.15 | 0.85 |
| G*9V*A12               | FC/MC/PC18A | 0.98 | 1.07 | 0.92 |
| G*9V*B12               | FC/MC/PC18B | 0.97 | 1.08 | 0.90 |
| G*9V*A12               | FC/MC/PC24A | 0.99 | 1.12 | 0.88 |
| G*9V*B12               | FC/MC/PC24B | 0.98 | 1.14 | 0.86 |
| G*9V*A12               | HC18        | 0.98 | 1.07 | 0.92 |
| G*9V*A12               | HD24        | 0.98 | 1.08 | 0.91 |
| G*9V*B12               | HD24        | 0.98 | 1.11 | 0.89 |
| G*9V*A12               | UC18A       | 0.98 | 1.08 | 0.91 |
| G*9V*B12               | UC18B       | 0.97 | 1.09 | 0.89 |
| G*9V*A12               | UC24A       | 0.99 | 1.13 | 0.88 |
| G*9V*B12               | UC24B       | 0.98 | 1.15 | 0.85 |

| <b>HEATING PERFORMANCE DATA</b>                    |   |                   |           |               |              |           |               |              |           |               |
|--|---|-------------------|-----------|---------------|--------------|-----------|---------------|--------------|-----------|---------------|
| <b>OUTDOOR UNIT MODEL NO.</b>                      |   | <b>HC3A024F1</b>  |           |               |              |           |               |              |           |               |
| <b>INDOOR COIL MODEL NO.</b>                       |   | <b>FC/MC/PC24</b> |           |               |              |           |               |              |           |               |
| <b>AIR TEMP.<br/>ENTERING<br/>OUTDOOR<br/>UNIT</b> | <b>AIR TEMP.<br/>ENTERING<br/>INDOOR<br/>COIL</b> | <b>ID CFM</b>     |           |               |              |           |               |              |           |               |
|  |   | <b>600</b>        |           |               | <b>800</b>   |           |               | <b>1000</b>  |           |               |
|  |   | <b>MBTUH</b>      | <b>KW</b> | <b>C.O.P.</b> | <b>MBTUH</b> | <b>KW</b> | <b>C.O.P.</b> | <b>MBTUH</b> | <b>KW</b> | <b>C.O.P.</b> |
| 60   | 60  | 28.2              | 1.9       | 3.9           | 28.9         | 1.7       | 4.2           | 29.7         | 1.6       | 4.5           |
|  | 70  | 27.5              | 2.2       | 3.3           | 28.2         | 2.0       | 3.6           | 28.9         | 1.8       | 4.0           |
|  | 80  | 26.9              | 2.5       | 2.9           | 27.6         | 2.2       | 3.2           | 28.2         | 2.0       | 3.5           |
| 47   | 60  | 23.6              | 1.9       | 3.3           | 23.9         | 1.7       | 3.5           | 24.3         | 1.5       | 3.8           |
|  | 70  | 23.1              | 2.1       | 2.9           | 23.6         | 1.9       | 3.2           | 24.0         | 1.7       | 3.4           |
|  | 80  | 22.7              | 2.3       | 2.6           | 23.2         | 2.1       | 2.8           | 23.8         | 1.9       | 3.1           |
| 40   | 60  | 20.7              | 1.7       | 3.1           | 21.4         | 1.6       | 3.3           | 22.1         | 1.5       | 3.5           |
|  | 70  | 20.5              | 2.0       | 2.8           | 21.1         | 1.8       | 2.9           | 21.7         | 1.7       | 3.1           |
|  | 80  | 20.4              | 2.2       | 2.5           | 20.9         | 2.0       | 2.6           | 21.3         | 1.9       | 2.8           |
| 30   | 60  | 17.6              | 1.6       | 2.8           | 18.3         | 1.5       | 2.9           | 18.9         | 1.4       | 3.1           |
|  | 70  | 17.1              | 1.9       | 2.4           | 18.0         | 1.7       | 2.6           | 18.8         | 1.6       | 2.8           |
|  | 80  | 16.6              | 2.1       | 2.1           | 17.6         | 1.9       | 2.3           | 18.7         | 1.8       | 2.5           |
| 17   | 60  | 14.3              | 1.5       | 2.4           | 14.8         | 1.4       | 2.5           | 15.2         | 1.4       | 2.6           |
|  | 70  | 13.6              | 1.7       | 2.1           | 14.3         | 1.6       | 2.2           | 15.0         | 1.6       | 2.3           |
|  | 80  | 12.9              | 1.9       | 1.8           | 13.8         | 1.8       | 1.9           | 14.7         | 1.7       | 2.1           |
| 10   | 60  | 11.8              | 1.5       | 2.1           | 12.0         | 1.4       | 2.1           | 12.3         | 1.3       | 2.2           |
|  | 70  | 11.5              | 1.5       | 1.9           | 11.6         | 1.6       | 1.8           | 11.8         | 1.6       | 1.8           |
|  | 80  | 11.2              | 1.6       | 1.8           | 11.3         | 1.7       | 1.6           | 11.3         | 1.9       | 1.5           |

**NOTE:** ALL CAPACITIES INCLUDE INDOOR FAN HEAT AT 1250 BTUH/1000 CFM.

#### Multipliers for determining the performance with other indoor section.

| <b>Air Handler</b> | <b>Coil</b>   | <b>MBH</b> | <b>KW</b> | <b>COP</b> |
|--------------------|---------------|------------|-----------|------------|
| MA08B              | FC/MC24B      | 1.00       | 1.00      | 1.00       |
| MA08B              | FC/MC30B      | 1.00       | 1.00      | 1.00       |
| MV12B              | FC/MC24B      | 0.98       | 1.06      | 0.93       |
| MV12B              | FC/MC30B      | 0.98       | 1.06      | 0.93       |
| AV24               | –             | 0.98       | 1.06      | 0.93       |
| AHP24              | –             | 1.00       | 1.00      | 1.00       |
| –                  | FC/MC/PC/UC30 | 1.00       | 1.00      | 1.00       |
| –                  | HC30          | 1.00       | 1.00      | 1.00       |
| –                  | HD24          | 1.00       | 1.00      | 1.00       |

| <b>Variable Speed Furnace</b> | <b>Coil</b> | <b>MBH</b> | <b>KW</b> | <b>COP</b> |
|-------------------------------|-------------|------------|-----------|------------|
| (F,L)C8V*A12                  | FC/MC/PC24A | 0.98       | 1.04      | 0.95       |
| FC9V*A12                      | FC/MC/PC24A | 0.98       | 1.04      | 0.95       |
| FC9(C,V)*B12                  | FC/MC/PC24B | 0.98       | 1.04      | 0.95       |
| (F,L)C8V*A12                  | FC/MC/PC30A | 0.98       | 1.04      | 0.94       |
| FC9V*A12                      | FC/MC/PC30A | 0.98       | 1.04      | 0.95       |
| FC9(C,V)*B12                  | FC/MC/PC30B | 0.98       | 1.04      | 0.94       |
| (F,L)C8V*A12                  | HC30        | 0.98       | 1.04      | 0.94       |
| FC9V*A12                      | HC30        | 0.98       | 1.04      | 0.95       |
| (F,L)C8V*A12                  | HD24        | 0.98       | 1.04      | 0.94       |
| FC9V*A12                      | HD24        | 0.98       | 1.04      | 0.95       |
| C*(8,L)C*A12                  | FC/MC/PC24A | 0.98       | 1.06      | 0.92       |
| C*(8,L)C*B12                  | FC/MC/PC24B | 0.98       | 1.08      | 0.91       |
| C*9C*B12                      | FC/MC/PC24B | 0.98       | 1.06      | 0.93       |
| C*(8,L)C*A12                  | FC/MC/PC30A | 0.98       | 1.06      | 0.92       |

| <b>Variable Speed Furnace</b> | <b>Coil</b> | <b>MBH</b> | <b>KW</b> | <b>COP</b> |
|-------------------------------|-------------|------------|-----------|------------|
| C*(8,L)C*B12                  | FC/MC/PC30B | 0.98       | 1.08      | 0.91       |
| C*9C*B12                      | FC/MC/PC30B | 0.98       | 1.06      | 0.93       |
| C*(8,L)C*A12                  | FC/MC/PC32A | 0.98       | 1.05      | 0.93       |
| C*(8,L)C*A12                  | HC30        | 0.98       | 1.03      | 0.95       |
| C*(8,L)C*A12                  | HD24        | 0.98       | 1.05      | 0.93       |
| C*(8,L)C*B12                  | HD24        | 0.97       | 1.06      | 0.92       |
| C*9C*B12                      | HD24        | 0.98       | 1.05      | 0.93       |
| C*(8,L)C*A12                  | UC24A       | 0.98       | 1.08      | 0.91       |
| C*(8,L)C*B12                  | UC24B       | 0.98       | 1.09      | 0.90       |
| C*9C*B12                      | UC24B       | 0.98       | 1.08      | 0.91       |
| C*(8,L)C*A12                  | UC30A       | 0.98       | 1.08      | 0.91       |
| C*(8,L)C*B12                  | UC30B       | 0.98       | 1.09      | 0.90       |
| C*9C*B12                      | UC30B       | 0.98       | 1.08      | 0.91       |
| G*9V*A12                      | FC/MC/PC24A | 0.98       | 1.05      | 0.94       |
| G*9V*B12                      | FC/MC/PC24B | 0.98       | 1.06      | 0.93       |
| G*9V*A12                      | FC/MC/PC30A | 0.98       | 1.05      | 0.94       |
| G*9V*B12                      | FC/MC/PC30B | 0.98       | 1.06      | 0.93       |
| G*9V*A12                      | FC/MC/PC32A | 0.99       | 1.04      | 0.95       |
| G*9V*A12                      | HC30        | 0.98       | 1.03      | 0.95       |
| G*9V*A12                      | HD24        | 0.98       | 1.03      | 0.95       |
| G*9V*B12                      | HD24        | 0.98       | 1.05      | 0.93       |
| G*9V*A12                      | UC24A       | 0.98       | 1.06      | 0.93       |
| G*9V*B12                      | UC24B       | 0.98       | 1.08      | 0.91       |
| G*9V*A12                      | UC30A       | 0.98       | 1.06      | 0.93       |
| G*9V*B12                      | UC30B       | 0.98       | 1.08      | 0.91       |

| <b>HEATING PERFORMANCE DATA</b>        |                                       |                  |           |               |              |           |               |              |           |               |
|--|---------------------------------------|------------------|-----------|---------------|--------------|-----------|---------------|--------------|-----------|---------------|
| <b>OUTDOOR UNIT MODEL NO.</b>          |                                       | <b>HC3A030F1</b> |           |               |              |           |               |              |           |               |
| <b>INDOOR COIL MODEL NO.</b>           |                                       | <b>AHP30</b>     |           |               |              |           |               |              |           |               |
| <b>AIR TEMP. ENTERING OUTDOOR UNIT</b> | <b>AIR TEMP. ENTERING INDOOR COIL</b> | <b>ID CFM</b>    |           |               |              |           |               |              |           |               |
|  |                                       | <b>800</b>       |           |               | <b>1000</b>  |           |               | <b>1200</b>  |           |               |
|  |                                       | <b>MBTUH</b>     | <b>KW</b> | <b>C.O.P.</b> | <b>MBTUH</b> | <b>KW</b> | <b>C.O.P.</b> | <b>MBTUH</b> | <b>KW</b> | <b>C.O.P.</b> |
| 60                                     | 60                                    | 36.0             | 2.2       | 4.2           | 36.8         | 2.1       | 4.4           | 37.7         | 2.0       | 4.6           |
|  | 70                                    | 35.2             | 2.5       | 3.8           | 36.2         | 2.3       | 4.0           | 37.2         | 2.2       | 4.2           |
|  | 80                                    | 34.5             | 2.7       | 3.4           | 35.6         | 2.5       | 3.6           | 36.6         | 2.4       | 3.8           |
| 47                                     | 60                                    | 29.9             | 2.1       | 3.7           | 30.9         | 2.0       | 3.9           | 32.0         | 1.9       | 4.1           |
|  | 70                                    | 29.6             | 2.3       | 3.4           | 30.6         | 2.2       | 3.5           | 31.5         | 2.1       | 3.7           |
|  | 80                                    | 29.4             | 2.5       | 3.1           | 30.2         | 2.4       | 3.2           | 31.0         | 2.3       | 3.4           |
| 40                                     | 60                                    | 27.7             | 2.0       | 3.5           | 28.5         | 1.9       | 3.7           | 29.3         | 1.8       | 3.8           |
|  | 70                                    | 27.2             | 2.2       | 3.2           | 28.0         | 2.1       | 3.3           | 28.8         | 2.0       | 3.4           |
|  | 80                                    | 26.8             | 2.4       | 2.9           | 27.5         | 2.3       | 3.0           | 28.2         | 2.2       | 3.1           |
| 30                                     | 60                                    | 21.5             | 1.9       | 2.9           | 23.2         | 1.8       | 3.1           | 24.8         | 1.8       | 3.3           |
|  | 70                                    | 22.3             | 2.1       | 2.7           | 23.3         | 2.0       | 2.8           | 24.2         | 1.9       | 3.0           |
|  | 80                                    | 23.2             | 2.4       | 2.6           | 23.4         | 2.2       | 2.6           | 23.6         | 2.1       | 2.7           |
| 17                                     | 60                                    | 18.8             | 1.7       | 2.8           | 18.9         | 1.8       | 2.6           | 19.1         | 1.8       | 2.5           |
|  | 70                                    | 18.4             | 2.0       | 2.4           | 18.6         | 2.0       | 2.4           | 18.8         | 1.9       | 2.3           |
|  | 80                                    | 18.0             | 2.3       | 2.1           | 18.3         | 2.1       | 2.1           | 18.6         | 2.0       | 2.2           |
| 10                                     | 60                                    | 16.6             | 1.8       | 2.4           | 16.8         | 1.7       | 2.4           | 17.1         | 1.7       | 2.4           |
|  | 70                                    | 16.1             | 2.0       | 2.1           | 16.5         | 1.9       | 2.1           | 16.8         | 1.8       | 2.2           |
|  | 80                                    | 15.7             | 2.2       | 1.8           | 16.1         | 2.1       | 1.9           | 16.5         | 2.0       | 2.0           |

**NOTE:** ALL CAPACITIES INCLUDE INDOOR FAN HEAT AT 1250 BTUH/1000 CFM.

#### Multipliers for determining the performance with other indoor sections.

| <b>Air Handler</b> | <b>Coil</b> | <b>MBH</b> | <b>KW</b> | <b>COP</b> |
|--------------------|-------------|------------|-----------|------------|
| MA12B              | FC/MC35B    | 1.00       | 1.00      | 1.00       |
| MA12B              | FC/MC42B    | 1.00       | 1.00      | 1.00       |
| MV12B              | FC/MC35B    | 0.98       | 1.05      | 0.93       |
| MV12B              | FC/MC42B    | 0.98       | 1.05      | 0.93       |
| AV36               | –           | 0.98       | 1.05      | 0.93       |
| F*FP040            | –           | 1.00       | 1.00      | 1.00       |
| –                  | FC/MC/PC35  | 1.00       | 1.00      | 1.00       |
| –                  | HC36        | 1.00       | 1.00      | 1.00       |
| –                  | HD36        | 1.00       | 1.00      | 1.00       |

| <b>Variable Speed Furnace</b> | <b>Coil</b> | <b>MBH</b> | <b>KW</b> | <b>COP</b> |
|-------------------------------|-------------|------------|-----------|------------|
| (F,L)C8V*B16                  | FC/MC/PC35B | 0.98       | 1.05      | 0.93       |
| FC9(C,V)*B12                  | FC/MC/PC35B | 0.98       | 1.06      | 0.93       |
| (F,L)C8V*B16                  | HC36        | 0.99       | 1.03      | 0.96       |
| FC9(C,V)*B12                  | HC36        | 0.99       | 1.03      | 0.96       |
| (F,L)C8V*A12                  | HD36        | 0.99       | 1.03      | 0.96       |
| (F,L)C8V*B16                  | HD36        | 0.98       | 1.05      | 0.93       |
| (F,L)C8V*C16                  | HD36        | 0.98       | 1.06      | 0.93       |

| <b>Variable Speed Furnace</b> | <b>Coil</b> | <b>MBH</b> | <b>KW</b> | <b>COP</b> |
|-------------------------------|-------------|------------|-----------|------------|
| (F,L)C8V*C20                  | HD36        | 0.98       | 1.06      | 0.93       |
| FC9V*A12                      | HD36        | 0.99       | 1.03      | 0.96       |
| FC9(C,V)*B12                  | HD36        | 0.99       | 1.03      | 0.96       |
| FC9(C,V)*C16                  | HD36        | 0.99       | 1.05      | 0.94       |
| FC9(C,V)*C20                  | HD36        | 0.99       | 1.05      | 0.94       |
| C*(8,L)C*A12                  | FC/MC/PC32A | 1.00       | 1.02      | 0.98       |
| C*(8,L)C*B12                  | FC/MC/PC35B | 0.99       | 1.05      | 0.94       |
| C*9C*B12                      | FC/MC/PC35B | 0.99       | 1.03      | 0.96       |
| C*(8,L)C*C16                  | FC/MC/PC35C | 0.98       | 1.06      | 0.93       |
| C*(8,L)C*C20                  | FC/MC/PC35C | 0.98       | 1.07      | 0.92       |
| C*9C*C16                      | FC/MC/PC35C | 0.98       | 1.06      | 0.93       |
| C*9C*C20                      | FC/MC/PC35C | 0.98       | 1.06      | 0.93       |
| C*(8,L)C*A12                  | FC/MC/PC37A | 0.99       | 1.05      | 0.95       |
| G*9V*A12                      | FC/MC/PC30A | 0.99       | 1.02      | 0.97       |
| G*9V*A12                      | FC/MC/PC32A | 0.99       | 1.03      | 0.96       |
| G*9V*B12                      | FC/MC/PC35B | 0.99       | 1.03      | 0.96       |
| G*9V*C16                      | FC/MC/PC35C | 0.98       | 1.06      | 0.93       |
| G*9V*C20                      | FC/MC/PC35C | 0.98       | 1.06      | 0.93       |
| G*9V*A12                      | FC/MC/PC37A | 0.99       | 1.05      | 0.95       |

| <b>HEATING PERFORMANCE DATA</b>                    |   |                   |           |               |              |           |               |              |           |               |
|--|---|-------------------|-----------|---------------|--------------|-----------|---------------|--------------|-----------|---------------|
| <b>OUTDOOR UNIT MODEL NO.</b>                      |   | <b>HC3A036F1</b>  |           |               |              |           |               |              |           |               |
| <b>INDOOR COIL MODEL NO.</b>                       |   | <b>FC/MC/PC48</b> |           |               |              |           |               |              |           |               |
| <b>AIR TEMP.<br/>ENTERING<br/>OUTDOOR<br/>UNIT</b> | <b>AIR TEMP.<br/>ENTERING<br/>INDOOR<br/>COIL</b> | <b>ID CFM</b>     |           |               |              |           |               |              |           |               |
|  |   | <b>1000</b>       |           |               | <b>1200</b>  |           |               | <b>1400</b>  |           |               |
|  |   | <b>MBTUH</b>      | <b>KW</b> | <b>C.O.P.</b> | <b>MBTUH</b> | <b>KW</b> | <b>C.O.P.</b> | <b>MBTUH</b> | <b>KW</b> | <b>C.O.P.</b> |
| 60   | 60  | 39.2              | 2.6       | 4.0           | 40.1         | 2.5       | 4.2           | 40.9         | 2.3       | 4.3           |
|  | 70  | 38.5              | 2.9       | 3.5           | 39.3         | 2.7       | 3.7           | 40.1         | 2.6       | 3.9           |
|  | 80  | 37.8              | 3.2       | 3.2           | 38.5         | 3.0       | 3.3           | 39.2         | 2.9       | 3.5           |
| 47   | 60  | 32.9              | 2.4       | 3.6           | 33.5         | 2.3       | 3.7           | 34.1         | 2.2       | 3.8           |
|  | 70  | 32.1              | 2.7       | 3.2           | 32.7         | 2.6       | 3.3           | 33.3         | 2.5       | 3.4           |
|  | 80  | 31.4              | 3.0       | 2.8           | 32.0         | 2.8       | 2.9           | 32.6         | 2.7       | 3.0           |
| 40   | 60  | 29.3              | 2.3       | 3.3           | 29.9         | 2.3       | 3.3           | 30.4         | 2.2       | 3.4           |
|  | 70  | 29.0              | 2.6       | 2.9           | 29.4         | 2.5       | 3.0           | 29.8         | 2.4       | 3.1           |
|  | 80  | 28.6              | 2.8       | 2.7           | 28.9         | 2.7       | 2.7           | 29.2         | 2.6       | 2.8           |
| 30   | 60  | 24.6              | 2.3       | 2.8           | 25.0         | 2.2       | 2.9           | 25.4         | 2.1       | 2.9           |
|  | 70  | 24.4              | 2.5       | 2.6           | 24.8         | 2.4       | 2.6           | 25.2         | 2.4       | 2.7           |
|  | 80  | 24.3              | 2.7       | 2.4           | 24.7         | 2.6       | 2.4           | 25.1         | 2.6       | 2.5           |
| 17   | 60  | 15.6              | 2.6       | 1.9           | 16.9         | 2.3       | 1.9           | 18.2         | 2.0       | 1.8           |
|  | 70  | 17.8              | 2.6       | 1.8           | 18.5         | 2.4       | 1.9           | 19.2         | 2.2       | 2.1           |
|  | 80  | 19.9              | 2.7       | 2.0           | 20.1         | 2.6       | 2.0           | 20.3         | 2.5       | 2.0           |
| 10   | 60  | 18.2              | 2.1       | 2.3           | 18.4         | 2.0       | 2.3           | 18.7         | 2.0       | 2.3           |
|  | 70  | 17.7              | 2.3       | 2.0           | 18.0         | 2.3       | 2.0           | 18.4         | 2.2       | 2.0           |
|  | 80  | 17.3              | 2.6       | 1.8           | 17.7         | 2.5       | 1.8           | 18.0         | 2.4       | 1.8           |

**NOTE:** ALL CAPACITIES INCLUDE INDOOR FAN HEAT AT 1250 BTUH/1000 CFM.

**Multipliers for determining the performance with other indoor sections.**

| <b>Air Handler</b> | <b>Coil</b>   | <b>MBH</b> | <b>KW</b> | <b>COP</b> |
|--------------------|---------------|------------|-----------|------------|
| MA12B              | FC/MC42B      | 0.97       | 1.00      | 1.00       |
| MA14D              | FC/MC48D      | 1.00       | 1.00      | 1.00       |
| MV16C              | FC/MC48C      | 1.00       | 1.05      | 0.94       |
| MV20D              | FC/MC48D      | 1.00       | 1.06      | 0.92       |
| AV36               | —             | 1.00       | 1.05      | 0.94       |
| AHP42              | —             | 1.00       | 1.00      | 1.00       |
| —                  | FC/MC/PC/UC42 | 0.97       | 1.00      | 1.00       |
| —                  | FC/MC/PC/UC48 | 1.00       | 1.00      | 1.00       |
| —                  | HC42          | 1.00       | 1.00      | 1.00       |
| —                  | HD48          | 1.00       | 1.00      | 1.00       |

Continued on Page 39.

| Variable Speed Furnace | Coil        | MBH  | KW   | COP  |
|------------------------|-------------|------|------|------|
| (F,L)C8V*B16           | FC/MC/PC42B | 0.94 | 0.90 | 0.95 |
| FC9(C,V)*B12           | FC/MC/PC42B | 0.94 | 0.88 | 0.95 |
| (F,L)C8V*C16           | FC/MC/PC42C | 0.94 | 0.90 | 0.95 |
| (F,L)C8V*C20           | FC/MC/PC42C | 0.94 | 0.88 | 0.95 |
| FC9(C,V)*C16           | FC/MC/PC42C | 0.94 | 0.90 | 0.95 |
| FC9(C,V)*C20           | FC/MC/PC42C | 0.94 | 0.88 | 0.95 |
| (F,L)C8V*C16           | FC/MC/PC48C | 0.98 | 0.98 | 0.95 |
| (F,L)C8V*C20           | FC/MC/PC48C | 0.98 | 0.98 | 0.95 |
| FC9(C,V)*C16           | FC/MC/PC48C | 0.98 | 0.97 | 0.97 |
| FC9(C,V)*C20           | FC/MC/PC48C | 0.98 | 0.97 | 0.97 |
| FC9(C,V)*D20           | FC/MC/PC48D | 0.98 | 0.97 | 0.97 |
| (F,L)C8V*C16           | HC42        | 0.98 | 0.98 | 0.95 |
| (F,L)C8V*C20           | HC42        | 0.98 | 0.98 | 0.95 |
| FC9(C,V)*C16           | HC42        | 0.98 | 0.97 | 0.97 |
| FC9(C,V)*C20           | HC42        | 0.98 | 0.97 | 0.97 |
| (F,L)C8V*C16           | HD48        | 0.98 | 0.98 | 0.95 |
| (F,L)C8V*C20           | HD48        | 0.98 | 0.98 | 0.95 |
| FC9(C,V)*C16           | HD48        | 0.98 | 0.97 | 0.97 |
| FC9(C,V)*C20           | HD48        | 0.98 | 0.97 | 0.97 |
| FC9(C,V)*D20           | HD48        | 0.98 | 0.97 | 0.96 |
| C*(8,L)C*A12           | FC/MC/PC37A | 0.98 | 0.98 | 1.00 |
| C*(8,L)C*B12           | FC/MC/PC43B | 0.99 | 1.02 | 0.97 |
| C*9C*B12               | FC/MC/PC43B | 0.99 | 1.02 | 0.97 |
| C*(8,L)C*C16           | FC/MC/PC43C | 0.98 | 1.05 | 0.94 |
| C*(8,L)C*C20           | FC/MC/PC43C | 0.98 | 1.05 | 0.93 |
| C*9C*C16               | FC/MC/PC43C | 0.99 | 1.03 | 0.96 |
| C*9C*C20               | FC/MC/PC43C | 0.99 | 1.04 | 0.94 |
| C*(8,L)C*C16           | FC/MC/PC48C | 0.98 | 1.06 | 0.93 |
| C*(8,L)C*C20           | FC/MC/PC48C | 0.98 | 1.07 | 0.92 |

| Variable Speed Furnace | Coil        | MBH  | KW   | COP  |
|------------------------|-------------|------|------|------|
| C*9C*C16               | FC/MC/PC48C | 0.99 | 1.05 | 0.94 |
| C*9C*C20               | FC/MC/PC48C | 1.00 | 1.06 | 0.94 |
| C*(8,L)C*C16           | HC42        | 0.98 | 1.05 | 0.94 |
| C*(8,L)C*C20           | HC42        | 0.98 | 1.06 | 0.93 |
| C*9C*C16               | HC42        | 0.99 | 1.03 | 0.96 |
| C*9C*C20               | HC42        | 0.99 | 1.04 | 0.94 |
| C*(8,L)C*B12           | HD48        | 0.98 | 0.95 | 1.03 |
| C*(8,L)C*C16           | HD48        | 0.97 | 0.96 | 1.01 |
| C*(8,L)C*C20           | HD48        | 0.97 | 0.97 | 1.00 |
| C*9C*B12               | HD48        | 0.98 | 0.95 | 1.04 |
| C*9C*C16               | HD48        | 0.97 | 0.96 | 1.02 |
| C*9C*C20               | HD48        | 0.98 | 0.97 | 1.01 |
| C*(8,L)C*C16           | UC48C       | 0.99 | 1.08 | 0.91 |
| C*(8,L)C*C20           | UC48C       | 0.98 | 1.09 | 0.90 |
| C*9C*C16               | UC48C       | 0.99 | 1.08 | 0.92 |
| C*9C*C20               | UC48C       | 1.00 | 1.08 | 0.93 |
| G*9V*A12               | FC/MC/PC37A | 0.99 | 1.00 | 0.99 |
| G*9V*B12               | FC/MC/PC43B | 0.99 | 1.02 | 0.97 |
| G*9V*C16               | FC/MC/PC43C | 0.99 | 1.03 | 0.96 |
| G*9V*C20               | FC/MC/PC43C | 0.99 | 1.04 | 0.94 |
| G*9V*C16               | FC/MC/PC48C | 0.99 | 1.05 | 0.94 |
| G*9V*C20               | FC/MC/PC48C | 1.00 | 1.06 | 0.94 |
| G*9V*C16               | HC42        | 0.99 | 1.03 | 0.96 |
| G*9V*C20               | HC42        | 0.99 | 1.04 | 0.94 |
| G*9V*B12               | HD48        | 0.98 | 0.95 | 1.04 |
| G*9V*C16               | HD48        | 0.97 | 0.96 | 1.02 |
| G*9V*C20               | HD48        | 0.98 | 0.97 | 1.01 |
| G*9V*C16               | UC48C       | 0.99 | 1.08 | 0.92 |
| G*9V*C20               | UC48C       | 1.00 | 1.08 | 0.93 |

| <b>HEATING PERFORMANCE DATA</b>                    |   |                   |           |               |              |           |               |              |           |               |
|--|---|-------------------|-----------|---------------|--------------|-----------|---------------|--------------|-----------|---------------|
| <b>OUTDOOR UNIT MODEL NO.</b>                      |   | <b>HC3A042F1</b>  |           |               |              |           |               |              |           |               |
| <b>INDOOR COIL MODEL NO.</b>                       |   | <b>FC/MC/PC60</b> |           |               |              |           |               |              |           |               |
| <b>AIR TEMP.<br/>ENTERING<br/>OUTDOOR<br/>UNIT</b> | <b>AIR TEMP.<br/>ENTERING<br/>INDOOR<br/>COIL</b> | <b>ID CFM</b>     |           |               |              |           |               |              |           |               |
|  |   | <b>1200</b>       |           |               | <b>1400</b>  |           |               | <b>1600</b>  |           |               |
|  |   | <b>MBTUH</b>      | <b>KW</b> | <b>C.O.P.</b> | <b>MBTUH</b> | <b>KW</b> | <b>C.O.P.</b> | <b>MBTUH</b> | <b>KW</b> | <b>C.O.P.</b> |
| 60   | 60  | 54.5              | 3.0       | 4.6           | 54.6         | 2.9       | 4.7           | 54.7         | 2.8       | 4.8           |
|  | 70  | 53.3              | 3.4       | 4.1           | 53.6         | 3.2       | 4.2           | 54.0         | 3.1       | 4.3           |
|  | 80  | 52.2              | 3.7       | 3.7           | 52.7         | 3.5       | 3.8           | 53.3         | 3.4       | 4.0           |
| 47   | 60  | 44.9              | 2.8       | 4.1           | 23.0         | 1.3       | 3.7           | 46.0         | 2.6       | 4.2           |
|  | 70  | 44.5              | 3.1       | 3.7           | 33.7         | 2.3       | 3.5           | 45.3         | 2.9       | 3.8           |
|  | 80  | 44.1              | 3.5       | 3.3           | 44.4         | 3.3       | 3.4           | 44.6         | 3.2       | 3.5           |
| 40   | 60  | 36.5              | 2.6       | 3.5           | 38.8         | 2.6       | 3.7           | 41.2         | 2.6       | 3.9           |
|  | 70  | 37.2              | 3.0       | 3.2           | 39.0         | 2.9       | 3.3           | 40.8         | 2.8       | 3.5           |
|  | 80  | 38.0              | 3.4       | 2.9           | 39.2         | 3.2       | 3.1           | 40.4         | 3.1       | 3.2           |
| 30   | 60  | 32.2              | 2.4       | 3.3           | 33.3         | 2.5       | 3.2           | 34.4         | 2.6       | 3.2           |
|  | 70  | 33.3              | 2.8       | 3.0           | 33.9         | 2.8       | 3.0           | 34.6         | 2.8       | 3.0           |
|  | 80  | 34.4              | 3.2       | 2.8           | 34.6         | 3.1       | 2.8           | 34.8         | 3.0       | 2.8           |
| 17   | 60  | 28.6              | 2.5       | 2.9           | 28.7         | 2.4       | 2.9           | 28.8         | 2.4       | 2.9           |
|  | 70  | 28.0              | 2.8       | 2.6           | 28.3         | 2.7       | 2.6           | 28.6         | 2.6       | 2.6           |
|  | 80  | 27.4              | 3.1       | 2.3           | 27.9         | 3.0       | 2.3           | 28.3         | 2.9       | 2.4           |
| 10   | 60  | 26.0              | 2.3       | 2.7           | 26.1         | 2.4       | 2.6           | 26.2         | 2.5       | 2.5           |
|  | 70  | 25.4              | 2.7       | 2.4           | 25.6         | 2.7       | 2.4           | 25.8         | 2.7       | 2.3           |
|  | 80  | 24.9              | 3.0       | 2.1           | 25.1         | 2.9       | 2.1           | 25.3         | 2.9       | 2.2           |

**NOTE:** ALL CAPACITIES INCLUDE INDOOR FAN HEAT AT 1250 BTUH/1000 CFM.

**Multipliers for determining the performance with other indoor sections.**

| <b>Air Handler</b> | <b>Coil</b> | <b>MBH</b> | <b>KW</b> | <b>COP</b> |
|--------------------|-------------|------------|-----------|------------|
| MA14D              | FC/MC60D    | 1.00       | 1.00      | 1.00       |
| MA16C              | FC60C       | 1.00       | 1.00      | 1.00       |
| MV20D              | FC/MC60D    | 1.00       | 1.04      | 0.96       |
| MV16C              | FC60C       | 1.00       | 1.04      | 0.96       |
| AV/SV48            | —           | 1.00       | 1.04      | 0.96       |
| AV/SV60            | —           | 1.00       | 1.04      | 0.96       |
| F*FV060            | —           | 1.00       | 1.04      | 0.96       |
| AHP/SHP48          | —           | 1.00       | 1.01      | 0.99       |
| AHP/SHP60          | —           | 1.00       | 1.04      | 0.96       |
| F*FP045            | —           | 1.00       | 1.01      | 0.99       |
| —                  | HC60        | 1.00       | 1.00      | 1.00       |
| —                  | HD60        | 1.00       | 1.00      | 1.00       |

Continued on Page 41.

| Variable Speed Furnace | Coil        | MBH  | KW   | COP  |
|------------------------|-------------|------|------|------|
| FC9(C,V)*D20           | FC/MC/PC60D | 1.00 | 1.02 | 0.98 |
| (F,L)C8V*C16           | FC/PC60C    | 1.00 | 1.02 | 0.98 |
| (F,L)C8V*C20           | FC/PC60C    | 1.00 | 1.03 | 0.97 |
| FC9(C,V)*C16           | FC/PC60C    | 1.00 | 1.02 | 0.98 |
| FC9(C,V)*C20           | FC/PC60C    | 1.00 | 1.02 | 0.98 |
| (F,L)C8V*C20           | HC60        | 1.00 | 1.03 | 0.97 |
| FC9(C,V)*C20           | HC60        | 1.00 | 1.02 | 0.98 |
| FC9(C,V)*D20           | HC60        | 1.00 | 1.02 | 0.98 |
| (F,L)C8V*C16           | HD60        | 1.00 | 1.02 | 0.98 |
| (F,L)C8V*C20           | HD60        | 1.00 | 1.03 | 0.97 |
| FC9(C,V)*C16           | HD60        | 1.00 | 1.02 | 0.98 |
| FC9(C,V)*C20           | HD60        | 1.00 | 1.02 | 0.98 |
| FC9(C,V)*D20           | HD60        | 1.00 | 1.02 | 0.98 |
| C*9C*D20               | FC/MC/PC60D | 0.99 | 1.01 | 0.98 |
| C*(8,L)C*C16           | FC/PC60C    | 0.99 | 1.01 | 0.98 |
| C*(8,L)C*C20           | FC/PC60C    | 0.98 | 1.01 | 0.97 |
| C*9C*C16               | FC/PC60C    | 0.99 | 0.99 | 1.01 |
| C*9C*C20               | FC/PC60C    | 0.99 | 1.00 | 0.99 |
| C*9C*D20               | FC/MC62D    | 0.99 | 1.02 | 0.97 |
| C*(8,L)C*C16           | HC60        | 0.99 | 1.04 | 0.95 |
| C*(8,L)C*C20           | HC60        | 0.99 | 1.05 | 0.94 |
| C*9C*C16               | HC60        | 1.00 | 1.02 | 0.98 |
| C*9C*C20               | HC60        | 0.99 | 1.03 | 0.97 |

| Variable Speed Furnace | Coil        | MBH  | KW   | COP  |
|------------------------|-------------|------|------|------|
| C*9C*D20               | HC60        | 0.99 | 1.03 | 0.96 |
| C*(8,L)C*C16           | HD60        | 0.98 | 0.95 | 1.03 |
| C*(8,L)C*C20           | HD60        | 0.98 | 0.96 | 1.02 |
| C*9C*C16               | HD60        | 0.99 | 0.93 | 1.06 |
| C*9C*C20               | HD60        | 0.98 | 0.94 | 1.05 |
| C*9C*D20               | HD60        | 0.98 | 0.95 | 1.04 |
| C*(8,L)C*C16           | UC60C       | 0.99 | 1.03 | 0.96 |
| C*(8,L)C*C20           | UC60C       | 0.98 | 1.04 | 0.95 |
| C*9C*C16               | UC60C       | 1.00 | 1.01 | 0.99 |
| C*9C*C20               | UC60C       | 0.99 | 1.02 | 0.98 |
| C*9C*D20               | UC60D       | 0.99 | 1.02 | 0.97 |
| G*9V*D20               | FC/MC/PC60D | 0.99 | 1.01 | 0.98 |
| G*9V*C16               | FC/PC60C    | 0.99 | 0.99 | 1.01 |
| G*9V*C20               | FC/PC60C    | 0.99 | 1.00 | 0.99 |
| G*9V*D20               | FC/MC62D    | 0.99 | 1.02 | 0.97 |
| G*9V*C16               | HC60        | 1.00 | 1.02 | 0.98 |
| G*9V*C20               | HC60        | 0.99 | 1.03 | 0.97 |
| G*9V*D20               | HC60        | 0.99 | 1.03 | 0.96 |
| G*9V*C16               | HD60        | 0.99 | 0.93 | 1.06 |
| G*9V*C20               | HD60        | 0.98 | 0.94 | 1.05 |
| G*9V*D20               | HD60        | 0.98 | 0.95 | 1.04 |
| G*9V*C16               | UC60C       | 1.00 | 1.01 | 0.99 |
| G*9V*C20               | UC60C       | 0.99 | 1.02 | 0.98 |
| G*9V*D20               | UC60D       | 0.99 | 1.02 | 0.97 |

| <b>HEATING PERFORMANCE DATA</b>                    |   |                   |           |               |              |           |               |              |           |               |
|--|---|-------------------|-----------|---------------|--------------|-----------|---------------|--------------|-----------|---------------|
| <b>OUTDOOR UNIT MODEL NO.</b>                      |   | <b>HC3A048F1</b>  |           |               |              |           |               |              |           |               |
| <b>INDOOR COIL MODEL NO.</b>                       |   | <b>FC/MC/PC60</b> |           |               |              |           |               |              |           |               |
| <b>AIR TEMP.<br/>ENTERING<br/>OUTDOOR<br/>UNIT</b> | <b>AIR TEMP.<br/>ENTERING<br/>INDOOR<br/>COIL</b> | <b>ID CFM</b>     |           |               |              |           |               |              |           |               |
|  |   | <b>1400</b>       |           |               | <b>1600</b>  |           |               | <b>1800</b>  |           |               |
|  |   | <b>MBTUH</b>      | <b>KW</b> | <b>C.O.P.</b> | <b>MBTUH</b> | <b>KW</b> | <b>C.O.P.</b> | <b>MBTUH</b> | <b>KW</b> | <b>C.O.P.</b> |
| 60   | 60  | 64.7              | 3.3       | 4.9           | 64.7         | 3.4       | 4.8           | 64.8         | 3.4       | 4.7           |
|  | 70  | 62.2              | 3.9       | 4.1           | 62.4         | 3.8       | 4.2           | 62.6         | 3.7       | 4.2           |
|  | 80  | 59.7              | 4.4       | 3.5           | 60.0         | 4.3       | 3.6           | 60.3         | 4.1       | 3.7           |
| 47   | 60  | 54.3              | 3.4       | 4.1           | 54.5         | 3.3       | 4.2           | 54.7         | 3.1       | 4.2           |
|  | 70  | 52.1              | 3.8       | 3.6           | 52.3         | 3.6       | 3.6           | 52.5         | 3.5       | 3.7           |
|  | 80  | 49.8              | 4.1       | 3.2           | 50.1         | 4.0       | 3.2           | 50.3         | 3.8       | 3.3           |
| 40   | 60  | 49.1              | 3.2       | 3.8           | 49.2         | 3.1       | 3.9           | 49.4         | 3.0       | 3.9           |
|  | 70  | 47.1              | 3.6       | 3.3           | 47.2         | 3.5       | 3.4           | 47.2         | 3.4       | 3.4           |
|  | 80  | 45.0              | 4.0       | 2.9           | 45.1         | 3.9       | 3.0           | 45.1         | 3.7       | 3.0           |
| 30   | 60  | 42.5              | 3.1       | 3.5           | 42.9         | 3.0       | 3.5           | 43.2         | 3.0       | 3.5           |
|  | 70  | 39.7              | 3.4       | 3.0           | 40.2         | 3.4       | 3.0           | 40.6         | 3.4       | 2.9           |
|  | 80  | 36.9              | 3.7       | 2.6           | 37.5         | 3.8       | 2.5           | 38.1         | 3.9       | 2.5           |
| 17   | 60  | 34.5              | 2.8       | 3.0           | 34.9         | 2.9       | 3.0           | 35.3         | 2.9       | 2.9           |
|  | 70  | 31.8              | 3.3       | 2.5           | 32.6         | 3.2       | 2.5           | 33.5         | 3.2       | 2.6           |
|  | 80  | 29.1              | 3.7       | 2.0           | 30.4         | 3.6       | 2.1           | 31.7         | 3.5       | 2.3           |
| 10   | 60  | 32.3              | 2.9       | 2.8           | 32.4         | 2.8       | 2.8           | 32.5         | 2.8       | 2.8           |
|  | 70  | 30.3              | 3.2       | 2.4           | 30.5         | 3.1       | 2.4           | 30.6         | 3.0       | 2.4           |
|  | 80  | 28.3              | 3.5       | 2.0           | 28.5         | 3.4       | 2.1           | 28.8         | 3.3       | 2.1           |

**NOTE:** ALL CAPACITIES INCLUDE INDOOR FAN HEAT AT 1250 BTUH/1000 CFM.

#### Multipliers for determining the performance with other indoor sections.

| <b>Air Handler</b> | <b>Coil</b> | <b>MBH</b> | <b>KW</b> | <b>COP</b> |
|--------------------|-------------|------------|-----------|------------|
| MA20D              | FC/MC60D    | 1.00       | 1.00      | 1.00       |
| MA16C              | FC60C       | 1.00       | 1.00      | 1.00       |
| MV20D              | FC/MC60D    | 1.00       | 1.03      | 0.97       |
| MV16C              | FC60C       | 1.00       | 1.03      | 0.97       |
| AV/SV48            | —           | 1.00       | 1.03      | 0.97       |
| AV/SV60            | —           | 1.00       | 1.03      | 0.97       |
| F*FV060            | —           | 1.00       | 1.03      | 0.97       |
| AHP/SHP48          | —           | 1.00       | 0.99      | 1.01       |
| AHP/SHP60          | —           | 1.00       | 1.02      | 0.98       |
| —                  | HC60        | 1.00       | 1.00      | 1.00       |
| —                  | HD60        | 1.00       | 1.00      | 1.00       |

| <b>Variable Speed Furnace</b> | <b>Coil</b> | <b>MBH</b> | <b>KW</b> | <b>COP</b> |
|-------------------------------|-------------|------------|-----------|------------|
| C*9C*D20                      | FC/MC/PC60D | 1.00       | 1.02      | 0.98       |
| C*9C*D20                      | FC/MC62D    | 1.00       | 1.04      | 0.96       |
| C*(8,L)C*C16                  | FC/PC60C    | 0.99       | 1.02      | 0.97       |
| C*(8,L)C*C20                  | FC/PC60C    | 0.99       | 1.03      | 0.96       |
| C*9C*C16                      | FC/PC60C    | 1.00       | 1.01      | 0.99       |
| C*9C*C20                      | FC/PC60C    | 1.00       | 1.01      | 0.99       |
| C*(8,L)C*C16                  | HD60        | 0.99       | 0.97      | 1.02       |
| C*(8,L)C*C20                  | HD60        | 0.99       | 0.98      | 1.01       |
| C*9C*C16                      | HD60        | 1.00       | 0.96      | 1.03       |
| C*9C*C20                      | HD60        | 1.00       | 0.96      | 1.03       |
| C*9C*D20                      | HD60        | 0.99       | 0.97      | 1.03       |
| C*(8,L)C*C16                  | UC60C       | 1.00       | 1.04      | 0.95       |
| C*(8,L)C*C20                  | UC60C       | 0.99       | 1.06      | 0.94       |
| C*9C*C16                      | UC60C       | 1.00       | 1.03      | 0.97       |
| C*9C*C20                      | UC60C       | 1.00       | 1.03      | 0.97       |
| C*9C*D20                      | UC60D       | 1.00       | 1.04      | 0.96       |
| G*9V*D20                      | FC/MC/PC60D | 1.00       | 1.02      | 0.98       |
| G*9V*D20                      | FC/MC62D    | 1.00       | 1.04      | 0.96       |
| G*9V*C16                      | FC/PC60C    | 1.00       | 1.01      | 0.99       |
| G*9V*C20                      | FC/PC60C    | 1.00       | 1.01      | 0.99       |
| G*9V*C16                      | HD60        | 1.00       | 0.96      | 1.03       |
| G*9V*C20                      | HD60        | 1.00       | 0.96      | 1.03       |
| G*9V*D20                      | HD60        | 0.99       | 0.97      | 1.03       |
| G*9V*C16                      | UC60C       | 1.00       | 1.03      | 0.97       |
| G*9V*C20                      | UC60C       | 1.00       | 1.03      | 0.97       |
| G*9V*D20                      | UC60D       | 1.00       | 1.04      | 0.96       |

| <b>Variable Speed Furnace</b> | <b>Coil</b> | <b>MBH</b> | <b>KW</b> | <b>COP</b> |
|-------------------------------|-------------|------------|-----------|------------|
| FC9(C,V)*D20                  | FC/MC/PC60D | 1.00       | 1.01      | 0.99       |
| (F,L)C8V*C16                  | FC/PC60C    | 1.00       | 1.01      | 0.99       |
| (F,L)C8V*C20                  | FC/PC60C    | 1.00       | 1.01      | 0.99       |
| FC9(C,V)*C16                  | FC/PC60C    | 1.00       | 1.00      | 1.00       |
| FC9(C,V)*C20                  | FC/PC60C    | 1.00       | 1.01      | 0.99       |
| (F,L)C8V*C20                  | HC60        | 1.00       | 1.01      | 0.99       |
| FC9(C,V)*C20                  | HC60        | 1.00       | 1.01      | 0.99       |
| FC9(C,V)*D20                  | HC60        | 1.00       | 1.01      | 0.99       |
| (F,L)C8V*C16                  | HD60        | 1.00       | 1.01      | 0.99       |
| (F,L)C8V*C20                  | HD60        | 1.00       | 1.01      | 0.99       |
| FC9(C,V)*C16                  | HD60        | 1.00       | 1.00      | 1.00       |
| FC9(C,V)*C20                  | HD60        | 1.00       | 1.01      | 0.99       |
| FC9(C,V)*D20                  | HD60        | 1.00       | 1.01      | 0.99       |

| HEATING PERFORMANCE DATA                 |   |            |     |        |       |     |        |       |     |        |
|--|---|------------|-----|--------|-------|-----|--------|-------|-----|--------|
| OUTDOOR UNIT MODEL NO.                   |   | HC3A060F1  |     |        |       |     |        |       |     |        |
| INDOOR COIL MODEL NO.                    |   | FC/MC/PC60 |     |        |       |     |        |       |     |        |
| AIR TEMP.<br>ENTERING<br>OUTDOOR<br>UNIT | AIR TEMP.<br>ENTERING<br>INDOOR<br>COIL | ID CFM     |     |        |       |     |        |       |     |        |
|  |   | 1600       |     |        | 1800  |     |        | 2000  |     |        |
|  |   | MBTUH      | KW  | C.O.P. | MBTUH | KW  | C.O.P. | MBTUH | KW  | C.O.P. |
| 60                                       | 60                                      | 75.6       | 4.6 | 4.8    | 76.1  | 4.4 | 5.1    | 76.6  | 4.2 | 5.3    |
|  | 70                                      | 72.9       | 5.1 | 4.2    | 73.4  | 4.9 | 4.4    | 73.8  | 4.6 | 4.7    |
|  | 80                                      | 70.2       | 5.6 | 3.7    | 70.6  | 5.3 | 3.9    | 71.0  | 5.1 | 4.1    |
| 47                                       | 60                                      | 63.8       | 4.3 | 4.4    | 64.2  | 4.1 | 4.6    | 64.7  | 3.9 | 4.8    |
|  | 70                                      | 61.4       | 4.8 | 3.8    | 61.8  | 4.6 | 4.0    | 62.2  | 4.4 | 4.2    |
|  | 80                                      | 59.0       | 5.3 | 3.3    | 59.3  | 5.0 | 3.4    | 59.6  | 4.8 | 3.6    |
| 40                                       | 60                                      | 53.1       | 4.0 | 3.9    | 53.2  | 4.2 | 3.7    | 53.3  | 4.3 | 3.6    |
|  | 70                                      | 48.9       | 4.4 | 3.3    | 49.3  | 4.6 | 3.1    | 49.6  | 4.8 | 3.0    |
|  | 80                                      | 44.7       | 4.7 | 2.7    | 45.4  | 5.0 | 2.7    | 46.0  | 5.2 | 2.6    |
| 30                                       | 60                                      | 47.5       | 4.1 | 3.4    | 48.8  | 3.9 | 3.6    | 50.2  | 3.7 | 3.9    |
|  | 70                                      | 46.6       | 4.5 | 3.0    | 47.3  | 4.4 | 3.2    | 48.1  | 4.2 | 3.4    |
|  | 80                                      | 45.7       | 4.9 | 2.7    | 45.8  | 4.8 | 2.8    | 45.9  | 4.6 | 2.9    |
| 17                                       | 60                                      | 38.3       | 3.8 | 2.9    | 40.1  | 3.6 | 3.2    | 41.9  | 3.5 | 3.5    |
|  | 70                                      | 36.8       | 4.0 | 2.7    | 38.4  | 4.0 | 2.8    | 40.0  | 3.9 | 3.0    |
|  | 80                                      | 35.3       | 4.3 | 2.4    | 36.7  | 4.3 | 2.5    | 38.1  | 4.4 | 2.6    |
| 10                                       | 60                                      | 33.1       | 3.4 | 2.9    | 34.5  | 3.5 | 2.9    | 36.0  | 3.6 | 2.9    |
|  | 70                                      | 33.2       | 3.9 | 2.5    | 34.0  | 3.9 | 2.5    | 34.7  | 3.9 | 2.6    |
|  | 80                                      | 33.4       | 4.4 | 2.2    | 33.4  | 4.3 | 2.2    | 33.4  | 4.3 | 2.3    |

**NOTE:** ALL CAPACITIES INCLUDE INDOOR FAN HEAT AT 1250 BTUH/1000 CFM.

#### Multipliers for determining the performance with other indoor sections.

| Air Handler | Coil     | MBH  | KW   | COP  |
|-------------|----------|------|------|------|
| MA20D       | FC/MC60D | 1.00 | 1.00 | 1.00 |
| MA20D       | MC61D    | 1.00 | 1.00 | 1.00 |
| MV20D       | FC/MC60D | 1.00 | 1.02 | 0.98 |
| MV20D       | MC61D    | 1.00 | 1.02 | 0.98 |
| AV/SV60     | –        | 1.00 | 1.02 | 0.98 |
| F*FV060     | –        | 1.00 | 1.02 | 0.98 |
| AHP/SHP60   | –        | 1.00 | 1.01 | 0.99 |
| –           | HC60     | 1.00 | 1.00 | 1.00 |
| –           | HD60     | 1.00 | 1.00 | 1.00 |
| –           | MC61     | 1.00 | 1.00 | 1.00 |

| Variable Speed Furnace | Coil        | MBH  | KW   | COP  |
|------------------------|-------------|------|------|------|
| FC9(C,V)*D20           | FC/MC/PC60D | 1.00 | 1.02 | 0.98 |
| (F,L)C8V*C20           | FC/PC60C    | 1.00 | 1.01 | 0.99 |
| FC9(C,V)*C20           | FC/PC60C    | 1.00 | 1.01 | 0.99 |
| (F,L)C8V*C20           | HC60        | 1.00 | 1.01 | 0.99 |
| FC9(C,V)*D20           | HC60        | 1.00 | 1.02 | 0.98 |
| (F,L)C8V*C20           | HD60        | 1.00 | 1.01 | 0.99 |
| FC9(C,V)*C20           | HD60        | 1.00 | 1.01 | 0.99 |
| FC9(C,V)*D20           | HD60        | 1.00 | 1.02 | 0.98 |
| (F,L)C8V*C20           | MC61D       | 1.00 | 1.01 | 0.99 |

| Variable Speed Furnace | Coil        | MBH  | KW   | COP  |
|------------------------|-------------|------|------|------|
| FC9(C,V)*C20           | MC61D       | 1.00 | 1.01 | 0.99 |
| FC9(C,V)*D20           | MC61D       | 1.00 | 1.02 | 0.98 |
| C*9C*D20               | FC/MC/PC60D | 0.95 | 0.99 | 1.00 |
| C*(8,L)C*C20           | FC/MC62D    | 0.95 | 0.98 | 1.06 |
| C*9C*D20               | FC/MC62D    | 0.95 | 1.01 | 0.98 |
| C*(8,L)C*C20           | FC/PC60C    | 0.95 | 1.00 | 0.99 |
| C*9C*C20               | FC/PC60C    | 0.95 | 0.99 | 1.00 |
| C*9C*D20               | HC60        | 0.95 | 1.02 | 0.97 |
| C*(8,L)C*C20           | HD60        | 0.95 | 0.94 | 1.04 |
| C*9C*C20               | HD60        | 0.95 | 0.96 | 1.03 |
| C*9C*D20               | HD60        | 0.95 | 0.93 | 1.06 |
| C*(8,L)C*C20           | UC60C       | 0.95 | 1.02 | 0.97 |
| C*9C*C20               | UC60C       | 0.95 | 1.00 | 0.99 |
| C*9C*D20               | UC60D       | 0.95 | 1.01 | 0.98 |
| G*9V*D20               | FC/MC/PC60D | 0.95 | 0.99 | 1.00 |
| G*9V*D20               | FC/MC62D    | 0.95 | 1.01 | 0.98 |
| G*9V*C20               | FC/PC60C    | 0.95 | 0.99 | 1.00 |
| G*9V*D20               | HC60        | 0.95 | 1.02 | 0.97 |
| G*9V*C20               | HD60        | 0.95 | 0.96 | 1.03 |
| G*9V*D20               | HD60        | 0.95 | 0.93 | 1.06 |
| G*9V*C20               | UC60C       | 0.95 | 1.00 | 0.99 |
| G*9V*D20               | UC60D       | 0.95 | 1.01 | 0.98 |

# NOTES