

# SUBMITTAL DATA SHEET



**ECHELON SPLIT SYSTEM AIR CONDITIONER UNITS**  
**13 SEER 1-1/2, 2, 2-1/2, 3, 3-1/2, 4 & 5 TON**  
**MODELS: AC3B018 THRU 060**

JOB NAME:			LOCATION:		
PURCHASER:			ORDER NO.:		
ENGINEER:					
SUBMITTED TO:	FOR:	REF:	APPROVAL:	CONSTRUCTION:	
SUBMITTED BY:			DATE:		
UNIT DESIGNATION:			SCHEDULE NO.	MODEL NO.	

**PRODUCT DATA**

**Cooling Performance**

Total Capacity \_\_\_\_\_ MBH  
 Outdoor Design Temp \_\_\_\_\_ °F

**Electrical Data**

Power Supply \_\_\_\_\_  
 Total Unit Ampacity \_\_\_\_\_ AMPS  
 Power Input Req \_\_\_\_\_ KW  
 Minimum Wire Size \_\_\_\_\_ AWG  
 Overcurrent Device  
 Fuses    Circuit Breaker

**Unit Weight**

Unit Weight \_\_\_\_\_ LBS

**DIMENSIONS - INCHES**

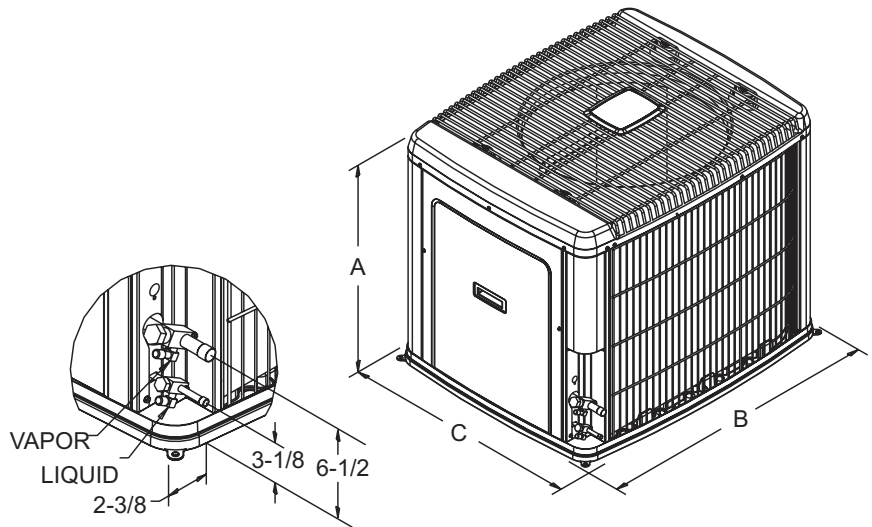

All dimensions are in inches. They are subject to change without notice. Certified dimensions will be provided upon request.

Unit Model	Dimensions (Inches)			Refrigerant Connection Service Valve Size	
	A	B	C	Liquid	Vapor
018	29-1/2	37	31	3/8"	3/4"
024	29-1/2	37	31		
030	33-1/2	37	31		
036	33-1/2	37	31		7/8"
042	39-1/2	37	31		
048	39-1/2	37	31		
060	39-1/2	37	31		



**FEATURES**

- UL approval (units & accessories)
- CSA listed and ARI certified
- 5-year limited parts warranty
- 10-year limited warranty on the compressor
- Copper tube/aluminum fin coil
- Hi and Lo pressure switches standard
- Durable construction
- Powder-painted steel cabinet
- Factory wired
- R-410A total system charge (thru 15 ft. of lines)
- Sweat refrigerant connections
- Re-usable service valves
- Slide down electrical compartment for easy access
- Enhanced coil guard
- Composite base pan
- Isolated compressor compartment
- Full service access panel

**MATCHING AIR SIDE EQUIPMENT**

Model No. ( )  
 Submittal Form No. ( )

**FIELD INSTALLED ACCESSORIES**

Dehumidification Control (2HU16700124) ( )  
 Thermostat ( )  
 Thermal Expansion Valve\* ( )  
 Low Ambient Pressure Switch Kit ( )  
 Hard Start Kit ( )

\* Must be installed for proper performance.

*(Refer to form 036-21555-001 for detailed specifications on the unit and its accessories.)*

**CLEARANCES**

Front of Unit .....24 inch  
 All Other Sides ..... 12 inch  
 Above Unit .....60 inch  
 Below Unit..... 0 inch

\*Must be installed for proper

**NOTES:**

---



---



---