

TECHNICAL GUIDE

SPLIT-SYSTEM HEAT PUMPS

14 SEER – R-22

**MODELS:
FRHS018 THRU 048
(1.5 THRU 4 NOMINAL TONS)**



Due to continuous product improvement, specifications are subject to change without notice.

Visit us on the web at www.york.com

Additional rating information can be found at www.ari.org/aridirectory

DESCRIPTION

The 14 SEER series heat pumps are designed for use with a variety of UPG evaporator sections to suit any application need. A full line of matching Add-On Coils are available for use with upflow, downflow or horizontal furnaces. Matching Air Handlers are also available for upflow, downflow or horizontal installation to provide a complete system. Electric heat may be installed in air handlers. All units are factory charged to assure easy installation.

WARRANTY

5-year limited parts warranty.
10-year limited compressor warranty.

FEATURES

- **DURABLE CONSTRUCTION** - The outdoor unit is constructed of pre-painted steel that offers tough protection against corrosion and resists fading when exposed to sunlight. Drain holes are incorporated into the base pan to permit free drainage of moisture.
- **QUALITY COILS** - The coil is constructed of enhanced copper tube and aluminum fins.
- **COIL PROTECTION** - Coils are protected from damage by a polymer mesh applied between the coil face, and a PVC coated steel coil guard.
- **PROTECTED COMPRESSOR** - The hermetic compressor is internally protected against high pressure and temperature by the simultaneous operation of a high pressure relief valve and temperature sensors which stop the compressor if operating temperatures go too high. Both protectors reset automatically. A discharge line solid core filter drier further protects the compressor.
- **Complete System Control** – These heat pumps utilize the unique microprocessor defrost control system to provide optimal comfort and to monitor the overall system for reliable operation. The defrost control system continuously monitors the space environment to maintain optimum efficiency. It initiates defrost only when necessary to further reduce heating costs and improve reliability. In the event improper operating conditions occur, the control will automatically shut the system down to extend the life of the heat pump. Rapid cycling is prevented by use of an internal anti-recycle timer.
- **LOW OPERATING SOUND LEVEL** - The compressor is mounted on rubber isolators to reduce operating sounds. The slow moving condenser fan keeps air turbulence and sound to a low level.
- **EASY ACCESS** - Removable panel affords accessibility to the electrical box.
- **FULLY CHARGED AND FACTORY WIRED** - to simply installation and reduce labor costs. Only power supply and control wiring and refrigerant lines must be connected. All models are sweat connect with reusable service valves.
- **Factory tested** - to verify system operation and control functioning before shipment.
- **U.L. and C.U.L. listed** - approved for outdoor application.

Certified in accordance with the Unitary Small Equipment certification program, which is based on ARI Standard 210/240.

PHYSICAL AND ELECTRICAL DATA - 1 PHASE

MODEL		FRHS0181BE	FRHS0241CD	FRHS0301CD	FRHS0361CD	FRHS0421CD	FRHS0481BD
Unit Supply Voltage		208-230V, 1 ϕ , 60Hz					
Normal Voltage Range ¹		187 to 252					
Minimum Circuit Ampacity		9.0	15.5	17.7	23.1	27.8	31.8
Max. Overcurrent Device Amps ²		15	25	30	40	45	50
Min. Overcurrent Device Amps ³		15	20	20	25	30	35
Compressor Type ⁴		Recip	Scroll ^C	Scroll ^C	Scroll ^C	Scroll ^C	Scroll ^D
Compressor Amps	Rated Load	6.8	11.8	13.6	17.4	21.2	24.4
	Locked Rotor	36.0	56.0	72.5	88.0	104.0	115.0
Crankcase Heater		Yes	No	No	No	No	No
Fan Motor Amps	Rated Load	1.5	.7	.7	1.3	1.3	1.3
	Fan Diameter Inches	22	24	24	24	24	24
Fan Motor	Rated HP	1/4	1/10	1/10	1/4	1/4	1/4
	Nominal RPM	850	850	850	850	850	850
	Nominal CFM	3,250	2,300	2,300	3,200	3,400	3,400
Coil	Face Area Sq. Ft.	18.3	18.0	18.0	22.5	22.5	27.0
	Rows Deep	1	2	2	2	2	2
	Fin / Inches	22	14	14	14	14	14
Liquid Line Set OD (Field Installed)		3/8	3/8	3/8	3/8	3/8	3/8
Vapor Line Set OD (Field Installed)		3/4	7/8	7/8	1-1/8	1-1/8	1-1/8
Unit Charge (Lbs. - Oz.) ⁵		8 - 1	10 - 5	12 - 4	14 - 7	14 - 7	14 - 10
Charge Per Foot, Oz.		.68	.70	.70	.76	.76	.76
Operating Weight Lbs.		198	212	215	242	252	266

1. Rated in accordance with ARI Standard 110, utilization range "A".
2. Dual element fuses or HACR circuit breaker. Maximum allowable overcurrent protection.
3. Dual element fuses or HACR circuit breaker. Minimum recommended overcurrent protection.
4. All scrolls listed with a superscript "D" are Danfoss scrolls. All scrolls listed with a superscript "C" are Copeland scrolls.
5. The Unit Charge is correct for the outdoor unit, matched indoor coil and 15 feet of refrigerant tubing. For tubing lengths other than 15 feet, add or subtract the amount of refrigerant, using the difference in length multiplied by the per foot value.

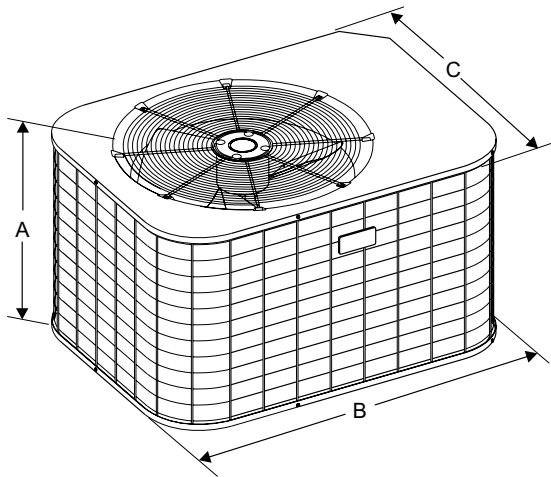

All dimensions are in inches. They are subject to change without notice. Certified dimensions will be provided upon request.

DIMENSIONS

Unit Model	Dimensions (Inches)			Refrigerant Connection Service Valve Size	
	A ¹	B	C	Liquid	Vapor
018	31	37	27	3/8	3/4
024	26	43	32		7/8
030	26	43	32		1-1/8
036	32	43	32		
042	32	43	32		
048	38	43	32		

1. Including Fan Guard.

Additional R-22 Charge / Orifice Size for Various Matched Systems - 1 Phase						
Outdoor Unit	FRHS0181BE	FRHS0241CD	FRHS0301CD	FRHS0361CD	FRHS0421CD	FRHS0481BD
Required TXV	1TVM2A1	1TVM2A1 or 1TVM701	1TVM2A1 or 1TVM701	1TVM2C1 or 1TVM702	1TVM2C1 or 1TVM703	1TVM703
Factory R-22 Charge, lbs-oz	8 - 1	10 - 5	12 - 4	14 - 7	14 - 7	14 - 10
Indoor Coil ^{1,2}	Additional Charge, Oz					
FC/MC/PC/UC36A2A	0	0	0	-	-	-
FC/MC/PC/UC36B2A	0	0	0	-	-	-
FC/MC/PC/UC36C2A	0	0	0	-	-	-
FC/MC/PC/UC42B2C	-	-	-	0	-	-
FC/MC/PC/UC42C2C	-	-	-	0	-	-
FC/MC/PC/UC48C2C	-	-	-	0	0	-
FC/MC/PC/UC48D2C	-	-	-	0	0	-
FC/PC/UC60C2C	-	-	-	0	0	-
FC/MC/PC/UC60D2C	-	-	-	0	0	-
MC61D2C	-	-	-	-	0	0
FC/MC62D2C	-	-	-	-	0	0
HC36B2A	0	-	-	-	-	-
HC42C2C	-	-	-	0	-	-
HC60C2C	-	-	-	-	0	-
HD36B2A	0	0	-	-	-	-
HD48C2C	-	-	-	0	-	-
HD60D2C	-	-	-	-	0	-
AHP24B2A	0	-	-	-	-	-
AHP30B2A	-	0	0	-	-	-
AHP36B2A	-	-	0	-	-	-
AHP42C2C	-	-	-	0	0	-
AHP/SHP48D2C	-	-	-	-	0	-
AHP/SHP60D2C	-	-	-	0	0	-
AV36C2A	-	0	0	-	-	-
AV/SV48D2C	-	-	-	0	0	-
AV/SV60D2C	-	-	-	-	0	-
MH30S	2	-	-	-	-	-
MH36S	-	0	0	-	-	-
MH42S	-	-	-	0	-	-
FC/MC/PC/UC35B3X	-	0	0	0	-	-
FC/MC/PC/UC35C3X	-	0	0	0	-	-
FC/MC/PC/UC36A3X	0	-	-	-	-	-
FC/MC/PC/UC36B3X	0	-	-	-	-	-
FC/MC/PC/UC36C3X	0	-	-	-	-	-
FC/MC/PC/UC42B3X	-	0	0	0	-	-
FC/MC/PC/UC42C3X	-	0	0	0	-	-
FC/MC/PC/UC48C3X	-	0	0	0	0	0
FC/MC/PC/UC48D3X	-	-	0	0	0	0
FC/PC/UC60C3X	-	-	0	0	0	0
FC/MC/PC/UC60D3X	-	-	0	0	0	0
FC/MC/PC61D3X	-	-	-	-	0	0
FC/MC62D3X	-	-	-	-	0	0
HC36B2A	0	-	-	-	-	-
HC42C3X	-	0	0	0	-	-
HC60C3X	-	-	-	-	0	0
HD36B3X	0	0	-	-	-	-
HD48C3X	-	-	0	0	-	-
HD60D3X	-	-	-	-	0	0

Additional R-22 Charge / Orifice Size for Various Matched Systems - 1 Phase (Continued)						
Outdoor Unit	FRHS0181BE	FRHS0241CD	FRHS0301CD	FRHS0361CD	FRHS0421CD	FRHS0481BD
Required TXV	1TVM2A1	1TVM2A1 or 1TVM701	1TVM2A1 or 1TVM701	1TVM2C1 or 1TVM702	1TVM2C1 or 1TVM703	1TVM703
Factory R-22 Charge, lbs-oz	8 - 1	10 - 5	12 - 4	14 - 7	14 - 7	14 - 10
Indoor Coil^{1,2}	Additional Charge, Oz					
AHP24B3X	0	–	–	–	–	–
AHP30B3X	–	0	0	–	–	–
AHP36B3X	–	–	0	0	–	–
AHP42C3X	–	–	–	0	0	–
AHP/SHP48D3X	–	–	–	–	0	0
AHP/SHP60D3X	–	–	–	0	0	0
AV36C3X	–	0	0	–	–	–
AV/SV48D3X	–	–	–	0	0	0
AV/SV60D3X	–	–	–	–	0	0
F*FP045H06	–	–	–	0	–	–
F*FV060H06	–	–	–	0	0	0

FOOTNOTES:

1. Systems matched with furnace or air handlers not equipped with blower-off delays may require blower Time Delay Kit 2FD06700224.
 2. PC coils cannot be used in downflow or horizontal applications. FC coils cannot be used in horizontal applications.
- * This loose coil match does not achieve 14 SEER.

PROCEDURES:

1. Unit factory charge listed on the unit nameplate includes refrigerant for the condenser, the smallest evaporator and 15 feet of inter-connecting line tubing.
2. Verify the TXV and additional charge required for specific evaporator coil in the system using the above table.
3. Additional charge for the amount of interconnecting line tubing greater than 15 feet at the rate specified in the table above.
4. Permanently mark the unit nameplate with the total system charge. Total System Charge = Base Charge (as shipped) + adder for evaporator + adder for line set.

COOLING CAPACITY - With Air Handler Coils

UNIT MODEL	AIR HANDLER		COIL MODEL ¹	COOLING				
	MODEL	W		RATED CFM	NET MBH		SEER	EER
					TOTAL	SENS.		
1 PH 14 SEER HP WITH MA								
FRHS0181BE	MA08B	17	FC/MC36B	800	17.0	11.7	14.00	12.00
FRHS0241CD	MA08B	17	FC/MC35B	800	24.0	17.7	14.00	12.00
	MA08B	17	FC/MC42B	800	24.0	17.7	14.00	12.00
FRHS0301CD	MA12B	17	FC/MC35B	1000	30.0	21.9	13.40	11.00
	MA12B	17	FC/MC42B	1000	30.0	21.9	13.40	11.00
FRHS0361CD	MA12B	17	FC/MC35B	1200	35.0	26.2	13.10	11.00
	MA12B	17	FC/MC42B	1200	35.0	26.2	13.10	11.00
	MA14D	24	FC/MC48D	1200	36.0	27.0	13.50	11.00
	MA14D	24	FC/MC60D	1200	36.0	27.0	13.80	11.00
FRHS0421CD	MA16C	21	FC/MC48C	1400	42.0	29.8	13.25	11.00
	MA14D	24	FC/MC48D	1400	42.0	29.8	13.25	11.00
	MA14D	24	FC/MC60D	1400	42.0	29.8	13.50	11.00
	MA16C	21	FC60C	1400	42.0	29.8	13.50	11.00
	MA14D	24	MC61D	1400	42.0	29.8	13.50	11.00
FRHS0481BD	MA16C	21	FC/MC48C	1600	45.0	32.4	13.00	11.00
	MA20D	24	FC/MC48D	1600	45.0	32.4	13.00	11.00
	MA20D	24	FC/MC60D	1600	45.5	32.7	13.25	11.00
	MA16C	21	FC60C	1600	45.5	32.7	13.25	11.00
	MA20D	24	MC61D	1600	46.0	33.1	13.50	11.00
1 PH 14 SEER HP WITH MV - VARIABLE SPEED								
FRHS0181BE	MV12B	17	FC/MC36B	600	17.5	12.0	15.00	12.00
FRHS0241CD	MV12B	17	FC/MC35B	775	24.0	18.3	15.00	12.00
	MV12B	17	FC/MC42B	775	24.0	18.3	15.00	12.00
FRHS0301CD	MV12B	17	FC/MC35B	1000	30.0	22.3	14.85	12.00
	MV16C	21	FC/MC35C	1050	30.0	22.3	15.00	12.00
	MV12B	17	FC/MC42B	1000	30.0	22.3	14.85	12.00
	MV16C	21	FC/MC42C	1050	30.0	22.3	15.00	12.00
	MV16C	21	FC/MC48C	1000	30.0	22.6	15.00	12.00
FRHS0361CD	MV12B	17	FC/MC42B	1200	35.4	26.5	13.75	11.00
	MV16C	21	FC/MC48C	1220	36.0	27.3	14.50	12.00
	MV20D	24	FC/MC48D	1220	36.0	27.3	15.00	12.00
	MV16C	21	FC60C	1220	36.0	27.3	14.75	12.00
	MV20D	24	FC/MC60D	1200	36.0	27.7	15.00	12.00
FRHS0421CD	MV16C	21	FC/MC48C	1425	42.0	30.5	14.00	12.00
	MV20D	24	FC/MC48D	1425	42.0	30.5	14.25	12.00
	MV16C	21	FC60C	1425	42.0	30.5	14.00	12.00
	MV20D	24	FC/MC60D	1420	42.0	31.2	15.00	12.00
	MV20D	24	MC61D	1420	42.0	31.2	15.00	12.00
FRHS0481BD	MV20D	24	FC/MC48D	1600	45.0	32.4	13.50	11.00
	MV20D	24	FC/MC60D	1600	46.0	33.1	13.75	11.00
	MV20D	24	MC61D	1600	46.5	33.4	14.00	12.00

For Notes See Page 6.

COOLING CAPACITY - With Air Handler Coils (Continued)

UNIT MODEL	AIR HANDLER		COIL MODEL ¹	COOLING				
	MODEL	W		RATED CFM	NET MBH		SEER	EER
					TOTAL	SENS.		
1 PH 14 SEER HP WITH AV / SV / F*FV - VARIABLE SPEED								
FRHS0181BE	AV24	17	—	600	17.5	12.0	15.00	12.00
FRHS0241CD	AV36	17	—	800	24.0	18.3	15.00	12.00
FRHS0301CD	AV36	17	—	1000	30.0	22.3	14.25	11.50
FRHS0361CD	AV36	17	—	1200	36.0	26.5	15.00	12.00
	AV/SV48	24	—	1200	36.0	27.3	14.65	11.50
	F*FV060	24	—	1200	36.0	26.5	15.00	12.50
FRHS0421CD	AV/SV48	24	—	1400	42.0	31.2	14.05	11.50
	F*FV060	24	—	1400	42.0	31.2	14.00	12.00
FRHS0481BD	AV/SV48	24	—	1600	46.0	32.4	14.05	11.50
	AV/SV60	24	—	1600	46.0	33.4	14.05	11.50
	F*FV060	24	—	1600	46.0	33.4	14.00	12.00
1 PH 14 SEER HP WITH AHP / SHP / F*FP								
FRHS0181BE	AHP24	17	—	655	17.0	11.7	14.00	12.00
FRHS0241CD	AHP30	17	—	800	24.0	17.7	14.00	12.00
FRHS0301CD	AHP36	17	—	1000	30.0	21.9	13.00	11.00
FRHS0361CD	AHP42	21	—	1200	35.0	26.2	13.10	11.00
	AHP/SHP60	24	—	1200	36.0	29.8	15.00	12.50
	F*FP045	24	—	1200	36.0	27.3	14.00	12.00
FRHS0421CD	AHP/SHP48	24	—	1400	42.0	29.8	13.50	11.00
	AHP/SHP60	24	—	1400	42.0	29.8	14.00	12.00
FRHS0481BD	AHP48	24	—	1600	45.5	32.7	13.25	11.00
	AHP/SHP60	24	—	1600	45.5	32.7	13.50	11.00
<p>Rated in accordance with DOE test procedures (Federal Register 12-27-79 and 3-18-88) and ARI Standards 210. Cooling MBH based on 80°F entering air temperature, 50% RH, and rated air flow. EER (Energy Efficiency Ratio) is the total cooling output in BTU's at 95°F outdoor ambient divided by the total electric power in watt-hours at those conditions. SEER (Seasonal Energy Efficiency Ratio) is the total cooling output in BTU's during a normal annual usage period for cooling divided by the total electric power input in watt-hours during the same period.</p>								

1. MC coils available with a factory installed horizontal drain pan. See price pages for specific model number.

— = Not applicable.

Go to www.ari.org/aridirectory for the latest additional matches.

COOLING CAPACITY - Upflow, Downflow & Horizontal Furnaces and Coils

UNIT MODEL	FURNACE**		COIL MODEL	COOLING				
	CFM RANGE (MIN.-MAX.)	W		RATED CFM	NET MBH		SEER ¹	EER
					TOTAL	SENS.		
FRHS0181BE	450 750	14,17,21	FC/MC/PC/UC36	600	17.0	11.7	14.00	12.00
		17	HC36	600	17.0	11.7	14.00	12.00
		-	HD36	600	17.0	11.7	14.00	12.00
		19	MH30S	600	17.0	11.7	14.00	11.50
FRHS0241CD	600 1000	17,21	FC/MC/PC35	800	24.0	17.7	14.00	12.00
		17,21	FC/MC/PC/UC42	800	24.0	17.7	14.00	12.00
		21,24	FC/MC/PC/UC48	800	24.0	17.7	14.00	12.00
		21	HC42	800	24.0	17.7	14.00	12.00
		-	HD36	800	24.0	17.7	14.00	12.00
		19	MH36S	800	24.0	11.7	14.00	11.50
FRHS0301CD	800 1200	17,21	FC/MC/PC35	1000	30.0	21.9	13.40	11.00
		17,21	FC/MC/PC/UC42	1000	30.0	21.9	13.40	11.00
		21,24	FC/MC/PC/UC48	1000	30.0	21.9	13.80	11.00
		21,24	FC/MC/PC/UC60	1000	30.0	21.9	13.80	11.00
		21	HC42	1000	30.0	21.9	13.70	11.00
		-	HD36	1000	29.4	21.4	13.50	11.00
		19	MH36S	1000	30.0	21.4	13.00	11.00
FRHS0361CD	1000 1400	17,21	FC/MC/PC35	1200	35.0	26.2	13.10	11.00
		17,21	FC/MC/PC/UC42	1200	35.0	26.2	13.10	11.00
		21,24	FC/MC/PC/UC48	1200	36.0	27.0	13.50	11.00
		21,24	FC/MC/PC/UC60	1200	36.0	27.0	13.80	11.00
		21	HC42	1200	35.6	26.7	13.20	11.00
		24	HC60	1200	35.4	26.5	13.70	11.00
		-	HD48	1200	35.6	26.7	13.20	11.00
		19	MH42S	1200	34.4	25.8	13.00	11.00
FRHS0421CD	1200 1600	21,24	FC/MC/PC/UC48	1400	42.0	29.8	13.25	11.00
		21,24	FC/MC/PC/UC60	1400	42.0	29.8	13.50	11.00
		24	HC60	1400	42.0	29.8	13.50	11.00
		-	HD60	1400	42.0	29.8	13.50	11.00
		24	MC61	1400	42.0	29.8	13.50	11.00
FRHS0481BD	1400 1800	21,24	FC/MC/PC/UC48	1600	45.0	32.4	13.00	11.00
		21,24	FC/MC/PC/UC60	1600	45.5	32.7	13.25	11.00
		24	HC60	1600	45.5	32.7	13.25	11.00
		-	HD60	1600	45.5	32.7	13.25	11.00
		24	MC61	1600	46.0	33.1	13.50	11.00
		24	FC/MC62	1600	46.0	33.1	13.50	11.00

1. Requires a 2FD06700224 Blower Time Delay unless a standard furnace is equipped with one.

** Refer to Quick Selection Chart for specific furnace match-up.

COOLING CAPACITY - With Variable Speed Furnaces

UNIT MODEL	VARIABLE SPEED FURNACE MODEL	COIL MODEL ¹	W	COOLING				
				RATED CFM	NET MBH		SEER	EER
					TOTAL	SENS.		
1 PH 14 SEER HP WITH VARIABLE SPEED FURNACES²								
FRHS0181BE	(F,L)C8V*A12	FC/MC/PC36A	14	600	17.5	12.0	15.00	12.00
	(F,L)C9V*B12	FC/MC/PC36B	17	600	17.5	12.0	15.00	12.00
	(F,L)C9V*A12	FC/MC/PC36A	14	600	17.5	12.0	15.00	12.00
	(F,L)C9V*B12	HC36	17	600	17.5	12.0	15.00	12.00
	(F,L)C9V*B12	HD36	-	600	17.5	12.0	15.00	12.00
FRHS0241CD	(F,L)C9V*B12	FC/MC/PC35B	17	800	24.0	18.3	15.00	12.00
	(F,L)C9V*B12	FC/MC/PC42B	17	800	24.0	18.3	15.00	12.00
	(F,L)C9V*B12	HD36	-	800	24.0	18.3	15.00	12.00
FRHS0301CD	(F,L)C9V*B12	FC/MC/PC35B	17	1000	30.0	22.3	14.50	12.00
	(F,L)C8V*B16	FC/MC/PC35B	17	1000	30.0	22.3	14.25	12.00
	(F,L)C8V*C16	FC/MC/PC35C	21	1000	30.0	22.3	15.00	12.00
	(F,L)C9V*C16	FC/MC/PC35C	21	1000	30.0	22.3	15.00	12.00
	(F,L)C9V*B12	FC/MC/PC42B	17	1000	30.0	22.3	14.50	12.00
	(F,L)C8V*B16	FC/MC/PC42B	17	1000	30.0	22.3	14.25	12.00
	(F,L)C8V*C16	FC/MC/PC42C	21	1000	30.0	22.3	15.00	12.00
	(F,L)C9V*C16	FC/MC/PC42C	21	1000	30.0	22.3	15.00	12.00
	(F,L)C8V*C16	FC/MC/PC48C	21	1000	30.0	22.3	15.00	12.00
	(F,L)C9V*C16	FC/MC/PC48C	21	1000	30.0	22.3	15.00	12.00
	(F,L)C9V*C16	FC/PC60C	21	1000	30.0	22.3	15.00	12.00
	(F,L)C8V*C16	FC/PC60C	21	1000	30.0	22.3	15.00	12.00
	(F,L)C9V*C16	HC42	21	1000	30.0	22.3	14.50	12.00
	(F,L)C8V*C16	HC42	21	1000	30.0	22.3	14.75	12.00
	(F,L)C8V*C20	HC42	21	1000	30.0	22.3	15.00	12.00
	(F,L)C9V*C16	HD36	-	1000	30.0	22.3	14.50	12.00
	(F,L)C8V*C16	HD36	-	1000	30.0	22.3	14.75	12.00
	(F,L)C8V*C20	HD36	-	1000	30.0	22.3	15.00	12.00

For Notes See Page 10.

COOLING CAPACITY - With Variable Speed Furnaces (Continued)

UNIT MODEL	VARIABLE SPEED FURNACE MODEL	COIL MODEL ¹	W	COOLING				
				RATED CFM	NET MBH		SEER	EER
					TOTAL	SENS.		
1 PH 14 SEER HP WITH VARIABLE SPEED FURNACES²								
FRHS0361CD	(F,L)C9V*B12	FC/MC/PC35B	17	1200	35.6	27.3	14.00	12.00
	(F,L)C8V*B16	FC/MC/PC35B	17	1200	35.2	27.3	13.50	11.00
	(F,L)C9V*C16	FC/MC/PC35C	21	1200	35.2	27.3	13.50	11.00
	(F,L)C9V*C20	FC/MC/PC35C	21	1200	35.2	27.3	13.75	11.00
	(F,L)C8V*C16	FC/MC/PC35C	21	1200	35.6	27.3	14.00	12.00
	(F,L)C8V*C20	FC/MC/PC35C	21	1200	35.6	27.3	14.00	12.00
	(F,L)C9V*B12	FC/MC/PC42B	17	1200	35.6	27.3	14.00	12.00
	(F,L)C8V*B16	FC/MC/PC42B	17	1200	35.2	27.3	13.50	11.00
	(F,L)C9V*C16	FC/MC/PC42C	21	1200	35.2	27.3	13.50	11.00
	(F,L)C9V*C20	FC/MC/PC42C	21	1200	35.2	27.3	13.75	11.00
	(F,L)C8V*C16	FC/MC/PC42C	21	1200	35.6	27.3	14.00	12.00
	(F,L)C8V*C20	FC/MC/PC42C	21	1200	35.6	27.3	14.00	12.00
	(F,L)C9V*C16	FC/MC/PC48C	21	1200	36.0	27.3	15.00	12.00
	(F,L)C9V*C20	FC/MC/PC48C	21	1200	36.0	27.3	15.00	12.00
	(F,L)C8V*C16	FC/MC/PC48C	21	1200	36.0	27.3	15.00	12.00
	(F,L)C8V*C20	FC/MC/PC48C	21	1200	36.0	27.3	15.00	12.00
	(F,L)C9V*D20	FC/MC/PC48D	24	1200	36.0	27.3	14.50	12.00
	(F,L)C9V*D20	FC/MC/PC60D	24	1200	36.0	27.3	15.00	12.00
	(F,L)C9V*C16	FC/PC60C	21	1200	36.0	27.3	15.00	12.00
	(F,L)C9V*C20	FC/PC60C	21	1200	36.0	27.3	15.00	12.00
	(F,L)C8V*C16	FC/PC60C	21	1200	36.0	27.3	15.00	12.00
	(F,L)C8V*C20	FC/PC60C	21	1200	36.0	27.3	15.00	12.00
	(F,L)C9V*C16	HC42	21	1200	36.0	27.3	14.25	12.00
	(F,L)C9V*C20	HC42	21	1200	36.0	27.3	14.25	12.00
	(F,L)C8V*C16	HC42	21	1200	36.0	27.3	14.25	12.00
	(F,L)C8V*C20	HC42	21	1200	36.0	27.3	14.50	12.00
	(F,L)C9V*D20	HC60	-	1200	36.0	27.3	15.00	12.00
	(F,L)C9V*C16	HD48	-	1200	36.0	27.3	14.25	12.00
	(F,L)C9V*C20	HD48	-	1200	36.0	27.3	14.25	12.00
	(F,L)C8V*C16	HD48	-	1200	36.0	27.3	14.25	12.00
(F,L)C8V*C20	HD48	-	1200	36.0	27.3	14.50	12.00	
FRHS0421CD	(F,L)C9V*C16	FC/MC/PC48C	21	1400	42.0	31.2	13.75	11.00
	(F,L)C9V*C20	FC/MC/PC48C	21	1400	42.0	31.2	14.00	12.00
	(F,L)C8V*C16	FC/MC/PC48C	21	1400	42.0	31.2	13.75	11.00
	(F,L)C8V*C20	FC/MC/PC48C	21	1400	42.0	31.2	13.75	11.00
	(F,L)C9V*D20	FC/MC/PC48D	24	1400	42.0	31.2	13.75	11.00
	(F,L)C9V*D20	FC/MC/PC60D	24	1400	42.0	31.2	14.00	12.00
	(F,L)C9V*C16	FC/PC60C	21	1400	42.0	31.2	14.00	12.00
	(F,L)C9V*C20	FC/PC60C	21	1400	42.0	31.2	14.00	12.00
	(F,L)C8V*C16	FC/PC60C	21	1400	42.0	31.2	14.00	12.00
	(F,L)C8V*C20	FC/PC60C	21	1400	42.0	31.2	14.00	12.00
	(F,L)C9V*D20	HC60	24	1400	42.0	31.2	14.00	12.00
	(F,L)C8V*C20	HD60	-	1400	42.0	31.2	14.00	12.00
	(F,L)C9V*D20	HD60	-	1400	42.0	31.2	14.00	12.00
	(F,L)C9V*D20	MC61D	24	1400	42.0	31.2	14.00	12.00

For Notes See Page 10.

COOLING CAPACITY - With Variable Speed Furnaces (Continued)

UNIT MODEL	VARIABLE SPEED FURNACE MODEL	COIL MODEL ¹	W	COOLING				
				RATED CFM	NET MBH		SEER	EER
					TOTAL	SENS.		
1 PH 14 SEER HP WITH VARIABLE SPEED FURNACES²								
FRHS0481BD	(F,L)C9V*C20	FC/MC/PC48C	21	1600	45.0	32.4	13.05	11.00
	(F,L)C8V*C20	FC/MC/PC48C	21	1600	45.0	32.4	13.25	11.00
	(F,L)C9V*D20	FC/MC/PC48D	24	1600	45.0	32.4	13.20	11.00
	(F,L)C9V*D20	FC/MC/PC60D	24	1600	45.5	32.4	13.35	11.00
	(F,L)C9V*C20	FC/PC60C	21	1600	45.5	32.4	13.25	11.00
	(F,L)C8V*C20	FC/PC60C	21	1600	45.5	32.4	13.50	11.00
	(F,L)C9V*D20	HC60	24	1600	45.5	32.4	13.35	11.00
	(F,L)C8V*C20	HD60	-	1600	45.5	32.4	13.50	11.00
	(F,L)C9V*C20	HD60	-	1600	45.5	32.4	13.25	11.00
	(F,L)C9V*D20	HD60	-	1600	45.5	32.4	13.35	11.00
(F,L)C9V*D20	MC61D	24	1600	44.5	32.4	13.50	11.00	

1. MC coils available with a factory installed horizontal drain pan. See price pages for specific model number.
2. Variable speed furnaces have B.O.D (Blower on Delay) standard.

HEATING CAPACITY - With Air Handler Coils

UNIT MODEL*	AIR HANDLER	COIL ¹ MODEL	ARI HEATING ²						
			47°F			17°F			HSPF
			MBH	COP	KW	MBH	COP	KW	STD
1 PH 14 SEER HP WITH MA									
FRHS0181BE	MA08B	FC/MC36B	17.0	3.50	1.42	9.8	2.36	1.22	8.20
FRHS0241CD	MA08B	FC/MC35B	23.8	3.64	1.91	14.8	2.50	1.73	8.50
	MA08B	FC/MC42B	23.8	3.64	1.91	14.8	2.50	1.73	8.50
FRHS0301CD	MA12B	FC/MC35B	30.0	3.30	2.66	20.6	2.40	2.51	8.00
	MA12B	FC/MC35B	30.0	3.30	2.66	20.6	2.40	2.51	8.00
	MA12B	FC/MC42B	30.0	3.30	2.66	20.6	2.40	2.51	8.00
	MA12B	FC/MC42B	30.0	3.30	2.66	20.6	2.40	2.51	8.00
FRHS0361CD	MA12B	FC/MC35B	36.0	3.64	2.89	23.0	2.40	2.80	8.10
	MA12B	FC/MC42B	36.0	3.64	2.89	23.0	2.40	2.80	8.10
	MA14D	FC/MC48D	36.0	3.84	2.74	23.2	2.54	2.67	8.60
	MA14D	FC/MC60D	36.0	3.84	2.74	23.2	2.50	2.71	9.00
FRHS0421CD	MA16C	FC/MC48C	42.0	3.80	3.23	27.2	2.54	3.13	8.75
	MA14D	FC/MC48D	42.0	3.80	3.23	27.2	2.54	3.13	8.75
	MA14D	FC/MC60D	42.0	3.74	3.29	27.2	2.54	3.13	9.00
	MA16C	FC60C	42.0	3.74	3.29	27.2	2.54	3.13	9.00
	MA14D	MC61D	42.0	3.64	3.38	27.2	2.60	3.06	9.00
FRHS0481BD	MA16C	FC/MC48C	46.0	3.50	3.85	27.4	2.36	3.40	8.00
	MA20D	FC/MC48D	46.0	3.50	3.85	27.4	2.36	3.40	8.00
	MA20D	FC/MC60D	45.5	3.52	3.78	28.0	2.40	3.41	8.10
	MA16C	FC60C	45.5	3.52	3.78	28.0	2.40	3.41	8.10
	MA20D	MC61D	45.0	3.78		28.6	2.56	3.27	9.00

For Notes See Page 11.

HEATING CAPACITY - With Air Handler Coils (Continued)

UNIT MODEL *	AIR HANDLER	COIL ¹ MODEL	ARI HEATING ²						
			47°F			17°F			HSPF
			MBH	COP	KW	MBH	COP	KW	STD
1 PH 14 SEER HP WITH MV - VARIABLE SPEED									
FRHS0181BE	MV12B	FC/MC36B	16.8	3.80	1.30	9.5	2.60	1.07	8.50
FRHS0241CD	MV12B	FC/MC35B	23.2	3.86	1.76	14.2	2.64	1.57	8.80
	MV12B	FC/MC42B	23.2	3.86	1.76	14.2	2.64	1.57	8.80
FRHS0301CD	MV12B	FC/MC35B	30.0	3.46	2.54	20.0	2.50	2.34	8.30
	MV16C	FC/MC35C	30.0	3.46	2.54	20.0	2.50	2.34	8.30
	MV12B	FC/MC42B	30.0	3.46	2.54	20.0	2.50	2.34	8.30
	MV16C	FC/MC42C	30.0	3.46	2.54	20.0	2.50	2.34	8.30
	MV16C	FC/MC48C	30.0	3.90	2.25	20.4	2.70	2.21	9.20
FRHS0361CD	MV12B	FC/MC35B	36.0	3.74	2.82	22.6	2.46	2.69	8.30
	MV12B	FC/MC42B	36.0	3.74	2.82	22.6	2.46	2.69	8.30
	MV16C	FC/MC48C	36.0	4.10	2.57	22.4	2.64	2.48	9.00
	MV20D	FC/MC48D	36.0	4.10	2.57	22.4	2.64	2.48	9.00
	MV16C	FC60C	36.0	4.10	2.57	22.4	2.64	2.48	9.00
	MV20D	FC/MC60D	36.0	3.84	2.74	22.4	2.64	2.48	9.00
FRHS0421CD	MV16C	FC/MC48C	42.0	3.90	3.15	26.6	2.70	2.88	9.10
	MV20D	FC/MC48D	42.0	3.90	3.15	26.6	2.70	2.88	9.10
	MV16C	FC60C	42.0	3.90	3.15	26.6	2.70	2.88	9.10
	MV20D	FC/MC60D	42.0	3.94	3.12	26.2	2.70	2.84	9.20
	MV20D	MC61D	42.0	3.94	3.12	26.2	2.70	2.84	9.20
FRHS0481BD	MV20D	FC/MC48D	46.0	3.54	3.80	27.2	2.38	3.34	8.00
	MV20D	FC/MC60D	45.0	3.62	3.64	27.4	2.46	3.26	8.20
	MV20D	MC61D	44.5	3.92	3.32	28.0	2.64	3.10	9.40
1 PH 14 SEER HP WITH AV / SV / F*FV - VARIABLE SPEED									
FRHS0181BE	AV24	—	16.8	3.80	1.30	9.5	2.60	1.07	8.75
FRHS0241CD	AV36	—	23.2	3.68	1.87	14.8	2.54	1.70	9.00
FRHS0301CD	AV36	—	30.0	3.46	2.54	20.0	2.50	2.34	8.80
FRHS0361CD	AV36	—	36.0	3.74	2.82	22.6	2.46	2.69	8.75
	AV/SV48	—	36.0	3.74	2.82	22.6	2.46	2.69	9.00
	F*FV060	—	36.0	4.10	2.57	22.4	2.64	2.49	9.00
FRHS0421CD	AV/SV48	—	42.0	3.90	3.15	26.6	2.70	2.88	9.30
	F*FV060	—	42.0	3.90	3.16	26.6	2.48	3.14	9.30
FRHS0481BD	AV/SV48	—	44.5	3.54	3.80	27.2	2.38	3.34	8.75
	AV/SV60	—	44.5	3.54	3.80	27.2	2.38	3.34	8.75
	F*FV060	—	44.5	3.62	3.60	27.4	2.36	3.40	8.75
1 PH 14 SEER HP WITH AHP / SHP / F*FP									
FRHS0181BE	AHP24	—	17.0	3.50	1.42	9.8	2.36	1.21	8.20
FRHS0241CD	AHP30	—	23.8	3.64	1.91	14.8	2.50	1.73	8.50
FRHS0301CD	AHP36	—	30.0	3.30	2.66	20.6	2.40	2.51	8.00
FRHS0361CD	AHP42	—	36.0	3.64	2.89	23.0	2.40	2.80	8.10
	F*FP045	—	36.0	3.80	2.85	23.4	2.54	2.69	9.00
	AHP/SHP60	—	36.0	3.80	2.85	23.4	2.54	2.69	9.00
FRHS0421CD	AHP/SHP48	—	42.0	3.74	3.29	27.2	2.54	3.13	9.00
	AHP/SHP60	—	42.0	3.74	3.29	27.2	2.54	3.13	9.00
FRHS0481BD	AHP/SHP48	—	45.5	3.52	3.78	28.0	2.40	3.41	8.10
	AHP/SHP60	—	45.5	3.52	3.78	28.0	2.40	3.41	8.10

1. Rated CFM same as for cooling.

2. Heating MBH based on ARI standards of 70° DB entering indoor air, 72% RH outdoor air with 25 feet of interconnecting piping and no supplemental electric heat operation.

CP equals MBH output divided by (total KW input x 3.412).

HSPF (Heating Seasonal Performance Factor) is the total heating output during a normal annual usage period for heating divided by the total electric power input during the same period.

— = Not Applicable.

HEATING CAPACITY - Upflow, Downflow & Horizontal Furnaces and Coils

UNIT MODEL*	COIL ¹ MODEL	ARI HEATING ²						
		47°F			17°F			HSPF
		MBH	COP	KW	MBH	COP	KW	
FRHS0181BE	FC/MC/PC/UC36	17.0	3.50	1.42	9.8	2.36	1.21	8.20
	HC36	17.0	3.50	1.42	9.8	2.36	1.21	8.20
	HD36	17.0	3.50	1.42	9.8	2.36	1.21	8.20
	MH30S	17.0	3.50	1.42	9.8	2.36	1.21	8.20
FRHS0241CD	FC/MC/PC/UC35	23.8	3.64	1.91	14.8	2.50	1.73	8.50
	FC/MC/PC/UC42	23.8	3.64	1.91	14.8	2.50	1.73	8.50
	FC/MC/PC/UC48	24.0	3.80	1.85	15.0	2.60	1.69	9.00
	HC42	23.8	3.64	1.91	14.8	2.50	1.73	8.50
	HD36	23.8	3.64	1.91	14.8	2.50	1.73	8.50
	MH36S	23.8	3.64	1.91	14.8	2.50	1.73	8.50
FRHS0301CD	FC/MC/PC/UC35	30.0	3.30	2.66	20.6	2.40	2.51	8.00
	FC/MC/PC/UC42	30.0	3.30	2.66	20.6	2.40	2.51	8.00
	FC/MC/PC/UC48	30.0	3.70	2.37	20.8	2.60	2.34	9.00
	FC/MC/PC/UC60	30.0	3.70	2.37	20.8	2.60	2.34	9.00
	HC42	30.0	3.44	2.55	20.2	2.44	2.42	8.40
	HD36	30.0	3.44	2.55	20.2	2.44	2.42	8.40
	MH36S	30.0	3.30	2.75	20.6	2.34	2.57	8.00
FRHS0361CD	FC/MC/PC/UC35	36.0	3.64	2.89	23.0	2.40	2.80	8.10
	FC/MC/PC/UC42	36.0	3.64	2.89	23.0	2.40	2.80	8.10
	FC/MC/PC/UC48	36.0	3.84	2.74	23.2	2.54	2.67	8.60
	FC/MC/PC/UC60	36.0	3.84	2.74	23.2	2.50	2.71	9.00
	HC42	36.0	3.70	2.85	23.4	2.44	2.80	8.25
	HC60	36.0	3.84	2.74	22.8	2.50	2.67	8.90
	HD48	36.0	3.70	2.85	23.4	2.44	2.80	8.25
	MH42S	36.0	3.60	3.04	23.0	2.40	2.80	8.00
FRHS0421CD	FC/MC/PC/UC48	42.0	3.80	3.23	27.2	2.54	3.13	8.75
	FC/MC/PC/UC60	42.0	3.74	3.29	27.2	2.54	3.13	9.00
	HC60	42.0	3.74	3.29	26.8	2.54	3.09	8.90
	HD60	42.0	3.74	3.29	26.8	2.54	3.09	8.90
	MC61	42.0	3.64	3.38	27.2	2.60	3.06	9.00
FRHS0481BD	FC/MC/PC/UC48	46.0	3.50	3.85	27.4	2.36	3.40	8.00
	FC/MC/PC/UC60	45.5	3.52	3.78	28.0	2.40	3.41	8.10
	HC60	45.5	3.52	3.78	28.0	2.40	3.41	8.10
	HD60	45.5	3.52	3.78	28.0	2.40	3.41	8.10
	MC61	45.0	3.78	3.48	28.6	2.56	3.27	9.00

1. Rated CFM same as for cooling.

2. Heating MBH based on ARI standards of 70° DB entering indoor air, 72% RH outdoor air with 25 feet of interconnecting piping and no supplemental electric heat operation.

CP equals MBH output divided by (total KW input x 3.412).

HSPF (Heating Seasonal Performance Factor) is the total heating output during a normal annual usage period for heating divided by the total electric power input during the same period.

— = Not Applicable.

HEATING CAPACITY - With Variable Speed Furnaces

UNIT MODEL	VARIABLE SPEED FURNACE	COIL ¹ MODEL	ARI HEATING ²						
			47°F			17°F			HSPF
			MBH	COP	KW	MBH	COP	KW	STD
1 PH 14 SEER HP WITH VARIABLE SPEED FURNACES									
FRHS0181BE	(F,L)C8V*A12	FC/MC/PC36A	16.8	3.80	1.30	9.5	2.60	1.07	8.75
	(F,L)C9V*B12	FC/MC/PC36B	16.8	3.80	1.30	9.5	2.60	1.07	8.75
	(F,L)C9V*A12	FC/MC/PC36B	16.8	3.80	1.30	9.5	2.60	1.07	8.75
	(F,L)C9V*B12	HC36	16.8	3.80	1.30	9.5	2.60	1.07	8.75
	(F,L)C9V*B12	HD36	16.8	3.80	1.30	9.5	2.60	1.07	8.75
FRHS0241CD	(F,L)C9V*B12	FC/MC/PC35B	23.2	3.86	1.76	14.2	2.64	1.57	8.65
	(F,L)C9V*B12	FC/MC/PC42B	23.2	3.86	1.76	14.2	2.64	1.57	8.65
	(F,L)C9V*B12	HD36	23.4	3.86	1.76	14.2	2.64	1.57	9.00
FRHS0301CD	(F,L)C9V*B12	FC/MC/PC35B	30.0	3.46	2.54	20.0	2.50	2.34	8.30
	(F,L)C8V*B16	FC/MC/PC35B	30.0	3.46	2.54	20.0	2.50	2.34	8.35
	(F,L)C9V*C16	FC/MC/PC35C	29.8	3.46	2.54	20.0	2.50	2.34	8.30
	(F,L)C8V*C16	FC/MC/PC35C	29.8	3.46	2.54	20.0	2.50	2.34	8.35
	(F,L)C9V*B12	FC/MC/PC42B	30.0	3.46	2.54	20.0	2.50	2.34	8.30
	(F,L)C8V*B16	FC/MC/PC42B	30.0	3.46	2.54	20.0	2.50	2.34	8.35
	(F,L)C9V*C16	FC/MC/PC42C	29.8	3.46	2.54	20.0	2.50	2.34	8.30
	(F,L)C8V*C16	FC/MC/PC42C	29.8	3.46	2.54	20.0	2.50	2.34	8.35
	(F,L)C8V*C16	FC/MC/PC48C	30.0	3.46	2.54	20.0	2.50	2.34	8.85
	(F,L)C9V*C16	FC/MC/PC48C	30.0	3.46	2.54	20.0	2.50	2.34	8.85
	(F,L)C9V*C16	FC/PC60C	30.0	3.46	2.54	20.0	2.50	2.34	8.30
	(F,L)C8V*C16	FC/PC60C	30.0	3.46	2.54	20.0	2.50	2.34	8.30
	(F,L)C9V*C16	HC42	30.0	3.46	2.54	20.0	2.50	2.34	8.55
	(F,L)C8V*C16	HC42	30.0	3.46	2.54	20.0	2.50	2.34	8.55
	(F,L)C8V*C20	HC42	30.0	3.46	2.54	20.0	2.50	2.34	8.80
	(F,L)C9V*C16	HD36	30.0	3.46	2.54	19.8	2.50	2.34	8.55
	(F,L)C8V*C16	HD36	30.0	3.46	2.54	19.8	2.50	2.34	8.55
(F,L)C8V*C20	HD36	30.0	3.46	2.54	19.8	2.50	2.34	8.80	

For Notes See Page 15.

HEATING CAPACITY - With Variable Speed Furnaces (Continued)

UNIT MODEL	VARIABLE SPEED FURNACE	COIL ¹ MODEL	ARI HEATING ²						
			47°F			17°F			HSPF
			MBH	COP	KW	MBH	COP	KW	STD
FRHS0361CD	(F,L)C9V*B12	FC/MC/PC35B	36.0	4.10	2.57	22.4	2.64	2.48	8.50
	(F,L)C8V*B16	FC/MC/PC35B	36.0	4.10	2.57	22.6	2.64	2.48	8.40
	(F,L)C9V*C16	FC/MC/PC35C	36.0	4.10	2.57	22.6	2.64	2.48	8.40
	(F,L)C9V*C20	FC/MC/PC35C	36.0	4.10	2.57	22.6	2.64	2.48	8.40
	(F,L)C8V*C16	FC/MC/PC35C	36.0	4.10	2.57	22.4	2.64	2.48	8.50
	(F,L)C8V*C20	FC/MC/PC35C	36.0	4.10	2.57	22.4	2.64	2.48	8.50
	(F,L)C9V*B12	FC/MC/PC42B	36.0	4.10	2.57	22.4	2.64	2.48	8.50
	(F,L)C8V*B16	FC/MC/PC42B	36.0	4.10	2.57	22.6	2.64	2.48	8.40
	(F,L)C9V*C16	FC/MC/PC42C	36.0	4.10	2.57	22.6	2.64	2.48	8.40
	(F,L)C9V*C20	FC/MC/PC42C	36.0	4.10	2.57	22.6	2.64	2.48	8.40
	(F,L)C8V*C16	FC/MC/PC42C	36.0	4.10	2.57	22.4	2.64	2.48	8.50
	(F,L)C8V*C20	FC/MC/PC42C	36.0	4.10	2.57	22.4	2.64	2.48	8.50
	(F,L)C9V*C16	FC/MC/PC48C	36.0	4.10	2.57	22.6	2.64	2.48	9.00
	(F,L)C9V*C20	FC/MC/PC48C	36.0	4.10	2.57	22.6	2.64	2.48	9.00
	(F,L)C8V*C16	FC/MC/PC48C	36.0	4.10	2.57	22.6	2.64	2.48	8.80
	(F,L)C8V*C20	FC/MC/PC48C	36.0	4.10	2.57	22.4	2.64	2.48	8.80
	(F,L)C9V*D20	FC/MC/PC48D	36.0	4.10	2.57	22.6	2.64	2.48	8.80
	(F,L)C9V*D20	FC/MC/PC60D	36.0	4.10	2.57	22.4	2.64	2.48	8.95
	(F,L)C9V*C16	FC/PC60C	36.0	4.10	2.57	22.6	2.64	2.48	9.00
	(F,L)C9V*C20	FC/PC60C	36.0	4.10	2.57	22.6	2.64	2.48	9.00
	(F,L)C8V*C16	FC/PC60C	36.0	4.10	2.57	22.6	2.64	2.48	9.00
	(F,L)C8V*C20	FC/PC60C	36.0	4.10	2.57	22.6	2.64	2.48	9.00
	(F,L)C9V*C16	HC42	36.0	4.10	2.57	23.2	2.64	2.48	8.65
	(F,L)C9V*C20	HC42	36.0	4.10	2.57	23.2	2.64	2.48	8.65
	(F,L)C8V*C16	HC42	36.0	4.10	2.57	23.2	2.64	2.48	8.65
	(F,L)C8V*C20	HC42	36.0	4.10	2.57	23.0	2.64	2.48	8.75
	(F,L)C9V*D20	HC60	36.0	4.10	2.57	22.4	2.64	2.48	8.95
	(F,L)C9V*C16	HD48	36.0	4.10	2.57	23.2	2.64	2.48	8.65
(F,L)C9V*C20	HD48	36.0	4.10	2.57	23.2	2.64	2.48	8.65	
(F,L)C8V*C16	HD48	36.0	4.10	2.57	23.2	2.64	2.48	8.65	
(F,L)C8V*C20	HD48	36.0	4.10	2.57	23.0	2.64	2.48	8.75	
FRHS0421CD	(F,L)C9V*C16	FC/MC/PC48C	42.0	3.90	3.15	26.8	2.70	2.88	8.55
	(F,L)C9V*C20	FC/MC/PC48C	42.0	3.90	3.15	26.8	2.70	2.88	8.55
	(F,L)C8V*C16	FC/MC/PC48C	42.0	3.90	3.15	26.8	2.70	2.88	8.55
	(F,L)C8V*C20	FC/MC/PC48C	42.0	3.90	3.15	26.8	2.70	2.88	8.55
	(F,L)C9V*D20	FC/MC/PC48D	42.0	3.90	3.15	26.8	2.70	2.88	8.55
	(F,L)C9V*D20	FC/MC/PC60D	42.0	3.90	3.15	26.8	2.70	2.88	8.60
	(F,L)C9V*C16	FC/PC60C	42.0	3.90	3.15	26.8	2.70	2.88	8.65
	(F,L)C9V*C20	FC/PC60C	42.0	3.90	3.15	26.6	2.70	2.88	8.60
	(F,L)C8V*C16	FC/PC60C	42.0	3.90	3.15	26.8	2.70	2.88	8.65
	(F,L)C8V*C20	FC/PC60C	42.0	3.90	3.15	26.8	2.70	2.88	9.15
	(F,L)C9V*D20	HC60	42.0	3.90	3.15	26.8	2.70	2.88	8.60
	(F,L)C8V*C20	HD60	42.0	3.90	3.15	26.8	2.70	2.88	8.60
	(F,L)C9V*D20	HD60	42.0	3.90	3.15	26.8	2.70	2.88	8.60
	(F,L)C9V*D20	MC61D	42.0	3.90	3.15	26.6	2.70	2.88	8.55

For Notes See Page 15.

HEATING CAPACITY - With Variable Speed Furnaces (Continued)

UNIT MODEL	VARIABLE SPEED FURNACE	COIL ¹ MODEL	ARI HEATING ²						
			47°F			17°F			HSPF
			MBH	COP	KW	MBH	COP	KW	STD
FRHS0481BD	(F,L)C9V*C20	FC/MC/PC48C	45.0	3.54	3.80	27.2	2.38	3.34	8.35
	(F,L)C8V*C20	FC/MC/PC48C	45.0	3.54	3.80	27.2	2.38	3.34	8.00
	(F,L)C9V*D20	FC/MC/PC48D	45.0	3.54	3.80	27.0	2.38	3.34	8.35
	(F,L)C9V*D20	FC/MC/PC60D	45.5	3.54	3.80	27.6	2.38	3.34	8.50
	(F,L)C9V*C20	FC/PC60C	45.5	3.54	3.80	27.8	2.38	3.34	8.50
	(F,L)C8V*C20	FC/PC60C	45.5	3.54	3.80	27.8	2.38	3.34	8.20
	(F,L)C9V*D20	HC60	45.0	3.54	3.80	27.6	2.38	3.34	8.50
	(F,L)C8V*C20	HD60	45.0	3.54	3.80	27.8	2.38	3.34	8.20
	(F,L)C9V*C20	HD60	45.0	3.54	3.80	27.8	2.38	3.34	8.50
	(F,L)C9V*D20	HD60	45.0	3.54	3.80	27.6	2.38	3.34	8.50
	(F,L)C9V*D20	MC61D	46.0	3.54	3.80	27.2	2.38	3.34	8.00

1. Rated CFM same as for cooling.

2. Heating MBH based on ARI standards of 70° DB entering indoor air, 72% RH outdoor air with 25 feet of interconnecting piping and no supplemental electric heat operation.

CP equals MBH output divided by (total KW input x 3.412).

HSPF (Heating Seasonal Performance Factor) is the total heating output during a normal annual usage period for heating divided by the total electric power input during the same period.

— = Not Applicable.

ACCESSORIES

Refer to Price Manual for specific model numbers.

Start Assist Kit (2SA067*)

Blower Time Delay - Available to increase efficiency when installed. Installs on indoor section and maintains blower for approximately one minute after cooling thermostat has been satisfied.

Hard Start Kits - Provides required starting torque for use with Thermal Expansion Valve Kit.

Low Temperature Cutout (2LT06700224) - Prevents heat pump operation below -10°F ambient temperature.

Compressor Blanket - Designed to further reduce the normal operating sound.

Add-on Fossil Fuel Control - Interface controls for use with gas, oil furnaces and the heat pump system are available.

Thermal Expansion Valve Kit - 1TVM700 Series TXV kit used to improve system performance.

ROOM THERMOSTATS - A wide selection of compatible thermostats are available to provide optimum performance and features for any installation.

1H/1C, manual changeover electronic non-programmable thermostat.

1H/1C, auto/manual changeover, electronic programmable, deluxe 7-day, thermostat.

1H/1C, auto/manual changeover, electronic programmable.

* For the most current accessory information, refer to the price book or consult factory.

SOUND POWER RATINGS*

UNIT MODEL	(dBA)
018	TBD
024	72
030	73
036	77
042	76
048	78

* Rated in accordance with ARI 270-95 Standards.

TYPICAL INSTALLATION

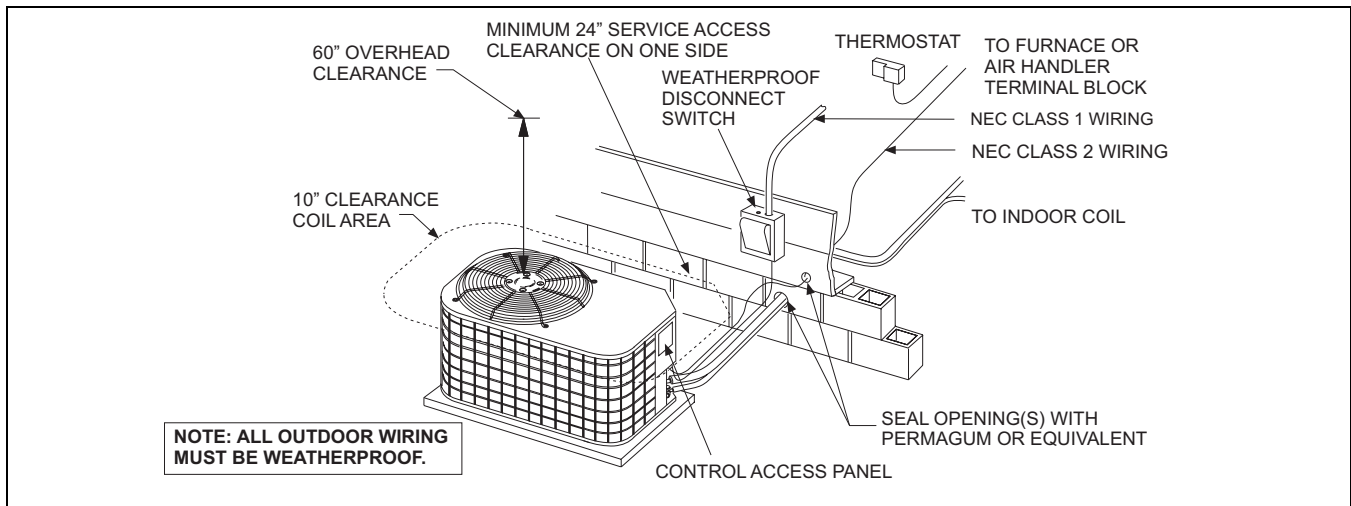

TYPICAL FIELD WIRING - 1 Phase Application

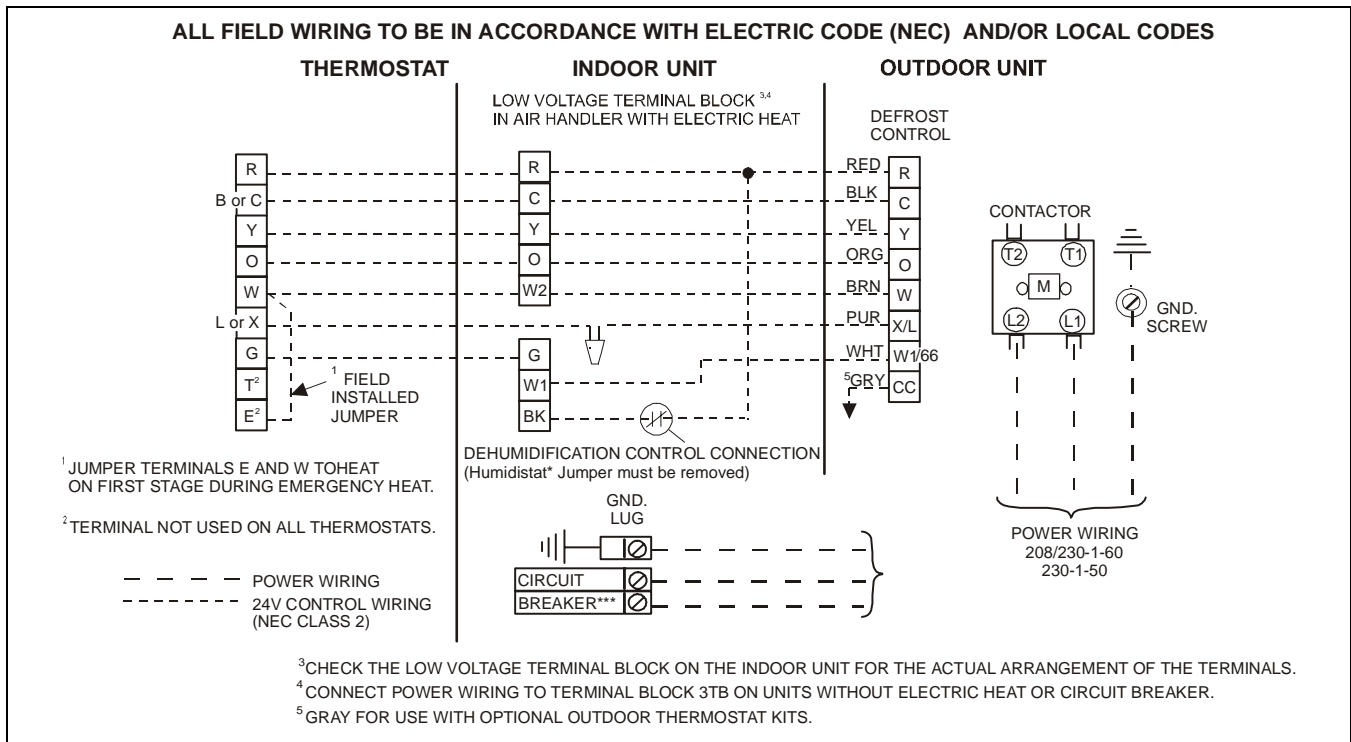

COOLING PERFORMANCE DATA																
AIR CONDITIONER MODEL NO.		FRHS0181BE														
INDOOR COIL MODEL NO.		FC/MC/PC36														
CONDENSING ENTERING AIR TEMPERATURE	IDCFM	450					600					750				
	ID DB (°F)	80	80	75	80	80	80	80	75	80	80	80	80	75	80	80
	ID WB (°F)	57	62	62	67	72	57	62	62	67	72	57	62	62	67	72
65	T.C.	16.7	17.9	17.6	20.9	23.4	18.3	18.8	19.2	21.1	24.4	19.9	19.7	20.7	21.3	25.4
	S.C.	16.3	13.9	11.9	12.8	10.6	18.1	16.1	14.1	13.8	11.6	19.8	18.2	16.2	14.9	12.6
	KW	1.0	1.0	1.0	1.0	1.0	1.0	1.0	1.0	1.0	0.9	1.0	1.0	1.0	0.9	0.9
75	T.C.	15.6	16.8	16.6	19.4	21.7	17.0	17.7	17.8	19.8	22.6	18.4	18.7	18.9	20.2	23.6
	S.C.	15.3	13.3	11.4	11.9	9.8	16.8	15.5	13.3	13.2	10.9	18.3	17.7	15.2	14.5	12.1
	KW	1.0	1.0	1.0	1.0	1.1	1.0	1.0	1.0	1.1	1.0	1.0	1.0	1.0	1.1	1.0
85	T.C.	14.6	15.7	15.6	17.8	20.0	15.7	16.6	16.4	18.4	20.9	16.8	17.6	17.1	19.0	21.8
	S.C.	14.4	12.7	10.9	11.1	9.1	15.6	14.9	12.6	12.6	10.3	16.8	17.1	14.2	14.1	11.5
	KW	1.1	1.1	1.1	1.1	1.1	1.1	1.1	1.1	1.1	1.2	1.1	1.1	1.1	1.2	1.2
95	T.C.	13.5	14.5	14.7	16.3	18.3	14.4	15.6	15.0	17.1	19.2	15.3	16.6	15.4	17.9	20.1
	S.C.	13.4	12.1	10.4	10.3	8.3	14.3	14.3	11.8	12.0	9.7	15.3	16.6	13.2	13.7	11.0
	KW	1.2	1.2	1.2	1.2	1.2	1.2	1.2	1.2	1.2	1.3	1.2	1.2	1.2	1.3	1.3
105	T.C.	12.5	13.3	13.4	15.0	17.0	13.3	14.1	13.7	15.6	17.7	14.1	15.0	14.1	16.2	18.3
	S.C.	12.4	11.5	9.7	9.6	7.8	13.2	13.2	11.1	11.2	9.0	14.0	14.9	12.5	12.8	10.2
	KW	1.3	1.3	1.3	1.3	1.3	1.3	1.3	1.3	1.3	1.4	1.3	1.3	1.3	1.3	1.4
115	T.C.	11.5	12.1	12.1	13.7	15.7	12.2	12.8	12.5	14.1	16.2	12.8	13.4	12.8	14.5	16.6
	S.C.	11.4	10.9	9.0	9.0	7.2	12.1	12.1	10.4	10.5	8.3	12.8	13.3	11.8	12.0	9.4
	KW	1.3	1.3	1.3	1.4	1.4	1.4	1.4	1.3	1.4	1.4	1.4	1.4	1.4	1.4	1.5
125	T.C.	10.5	11.0	10.9	12.5	14.4	11.0	11.4	11.2	12.7	14.7	11.6	11.8	11.6	12.9	14.9
	S.C.	10.4	10.3	8.3	8.3	6.7	11.0	11.0	9.7	9.7	7.6	11.5	11.7	11.1	11.2	8.6
	KW	1.4	1.4	1.4	1.5	1.5	1.4	1.4	1.4	1.5	1.5	1.5	1.5	1.4	1.5	1.6

NOTE: ALL CAPACITIES INCLUDE INDOOR FAN HEAT AT 1250 BTUH/1000 CFM.

Multipliers for determining the performance with other indoor sections.

NOTE: For dry bulb temperatures different than those listed (between 73-87 F), sensible capacity increases by 1060 BTUH per 1000 CFM per degree above the listed temperature and decreases by 1060 BTUH per 1000 CFM per degree below the listed temperature.

Air Handler	Coil	T.C.	S.C.	KW
MA08B	F /MC36B	1.00	1.00	1.00
AHP24	–	1.00	1.00	1.00
MV12B	FC/MC36B	1.03	1.03	0.96
AV24	–	1.03	1.03	0.96
–	HC36	1.00	1.00	1.00
–	HD36	1.00	1.00	1.00
–	MH30S	1.00	1.00	1.00

Variable Speed Furnace	Coil	T.C.	S.C.	KW
(F,L)C8V*A12	FC/MC/PC36A	1.03	1.03	0.96
(F,L)C9V*B12	FC/MC/PC36B	1.03	1.03	0.96
(F,L)C9V*A12	FC/MC/PC36B	1.03	1.03	0.96
(F,L)C9V*B12	HC36	1.03	1.03	0.96
(F,L)C9V*B12	HD36	1.03	1.03	0.96

COOLING PERFORMANCE DATA										
AIR CONDITIONER MODEL NO.		FRHS0241CD								
INDOOR COIL MODEL NO.		FC/MC/PC/UC48								
CONDENSER ENTERING AIR TEMPERATURE	ID CFM	600			800			1000		
	ID DB (°F)	85	80	70	85	80	70	85	80	70
	ID WB (°F)	72	67	57	72	67	57	72	67	57
75	T.C.	28.0	25.8	23.5	28.5	26.7	24.6	29.0	27.6	25.8
	S.C.	18.1	16.9	16.8	19.3	18.6	18.8	20.4	20.3	20.9
	KW	1.63	1.61	1.60	1.70	1.68	1.67	1.78	1.76	1.75
85	T.C.	26.4	24.5	22.4	27.2	25.6	23.5	28.0	26.6	24.6
	S.C.	17.6	16.6	16.9	19.3	18.5	18.7	20.9	20.4	20.5
	KW	1.79	1.77	1.76	1.86	1.84	1.83	1.94	1.92	1.91
95	T.C.	24.8	23.2	21.4	26.0	24.4	22.4	27.1	25.6	23.5
	S.C.	16.3	15.6	16.4	18.5	17.8	18.0	20.7	19.9	19.5
	KW	1.94	1.93	1.91	2.01	2.00	1.98	2.09	2.08	2.06
105	T.C.	23.3	22.0	20.3	24.7	23.2	21.3	26.1	24.4	22.3
	S.C.	15.8	15.6	16.2	18.4	17.7	17.9	21.0	19.8	19.6
	KW	2.15	2.13	2.12	0.22	2.20	2.19	2.30	2.28	2.27
115	T.C.	21.9	20.8	19.2	23.5	22.0	20.1	25.2	23.2	21.0
	S.C.	14.6	14.9	15.3	17.6	16.9	17.1	20.5	19.0	19.0
	KW	2.23	2.34	2.33	2.42	2.41	2.40	2.50	2.49	2.48
125	T.C.	20.4	19.5	18.1	22.2	20.7	19.0	24.2	21.9	19.8
	S.C.	13.5	14.2	14.5	16.9	16.1	16.4	20.1	18.2	18.5
	KW	2.31	2.55	2.54	4.62	2.62	2.61	2.70	2.70	2.69

NOTE: ALL CAPACITIES INCLUDE INDOOR FAN HEAT AT 1250 BTUH/1000 CFM.

Multipliers for determining the performance with other indoor sections.

NOTE: For dry bulb temperatures different than those listed (between 73-87 F), sensible capacity increases by 1060 BTUH per 1000 CFM per degree above the listed temperature and decreases by 1060 BTUH per 1000 CFM per degree below the listed temperature.

Air Handler	Coil	T.C.	S.C.	KW
MA08B	FC/MC35B	1.00	0.98	1.00
MA08B	FC/MC42B	1.00	0.98	1.00
AHP30	–	1.00	0.98	1.00
MV12B	FC/MC35B	1.00	1.02	0.96
MV12B	FC/MC42B	1.00	1.02	0.96
AV36	–	1.00	1.02	0.96
–	FC/MC/PC35	1.00	0.98	1.00
–	FC/MC/PC/UC42	1.00	0.98	1.00
–	HC42	1.00	0.98	1.00
–	HD36	1.00	0.98	1.00
–	MH36S	1.00	0.99	1.00

Variable Speed Furnace	Coil	T.C.	S.C.	KW
(F,L)C9V*B12	FC/MC/PC35	1.00	1.02	0.96
(F,L)C9V*B12	FC/MC/PC42	1.00	1.02	0.96
(F,L)C9V*B12	HD36	1.00	1.02	0.96

COOLING PERFORMANCE DATA										
AIR CONDITIONER MODEL NO.		FRHS0301CD								
INDOOR COIL MODEL NO.		FC/MC48D + MA14D								
CONDENSER ENTERING AIR TEMPERATURE	ID CFM	800			1000			1200		
	ID DB (°F)	85	80	70	85	80	70	85	80	70
	ID WB (°F)	72	67	57	72	67	57	72	67	57
75	T.C.	34.7	32.3	29.7	35.7	33.5	30.8	36.7	34.7	31.9
	S.C.	20.9	19.8	20.6	22.9	22.0	22.5	24.9	24.2	24.4
	KW	1.95	1.99	1.99	2.03	2.05	2.07	2.10	2.12	2.14
85	T.C.	33.0	30.8	28.5	34.1	32.0	29.5	35.1	33.1	30.4
	S.C.	20.1	19.3	19.9	22.4	21.5	21.8	24.6	23.7	23.8
	KW	2.21	2.22	2.22	2.29	2.30	2.30	2.36	2.37	2.37
95	T.C.	31.3	29.4	27.3	32.4	30.5	28.1	33.5	31.6	28.9
	S.C.	19.4	18.8	19.2	21.9	21.0	21.2	24.4	23.2	23.2
	KW	2.47	2.47	2.46	2.55	2.55	2.54	2.62	2.62	2.61
105	T.C.	29.8	28.0	26.0	30.7	28.9	26.7	31.7	29.9	27.5
	S.C.	18.9	18.2	18.8	21.3	20.4	20.8	22.6	21.5	21.8
	KW	2.74	2.73	2.72	2.82	2.81	2.80	2.89	2.88	2.87
115	T.C.	28.2	26.5	24.6	29.0	27.3	25.3	29.8	28.1	26.0
	S.C.	18.4	17.7	18.4	20.8	19.9	20.3	20.8	19.9	20.3
	KW	3.00	2.99	2.98	3.08	3.07	3.06	3.15	3.14	3.13
125	T.C.	26.6	25.1	23.3	27.3	25.8	24.0	27.9	26.4	24.6
	S.C.	18.0	17.1	18.0	20.3	19.3	19.8	19.1	18.2	18.8
	KW	3.26	3.25	3.24	3.34	3.33	3.32	3.41	3.40	3.39

NOTE: ALL CAPACITIES INCLUDE INDOOR FAN HEAT AT 1250 BTUH/1000 CFM.

Multipliers for determining the performance with other indoor sections.

NOTE: For dry bulb temperatures different than those listed (between 73-87 F), sensible capacity increases by 1060 BTUH per 1000 CFM per degree above the listed temperature and decreases by 1060 BTUH per 1000 CFM per degree below the listed temperature.

Air Handler	Coil	T.C.	S.C.	KW
MA12B	FC/MC35B	1.00	1.00	1.00
MA12B	FC/MC42B	1.00	1.00	1.00
AHP36	-	1.00	1.00	1.00
F*FP045	-	1.00	1.02	0.96
MV12B	FC/MC35B	1.00	1.02	0.96
MV16C	FC/MC35C	1.00	1.02	0.92
MV12B	FC/MC42B	1.00	1.02	0.96
MV16C	FC/MC42C	1.00	1.02	0.92
MV16C	FC/MC48C	1.00	1.03	0.92
MV16C	FC60C	1.00	1.02	0.92
AV36	-	1.00	1.02	0.96
-	FC/MC/PC35	1.00	1.00	1.00
-	FC/MC/PC/UC42	1.00	1.00	1.00
-	FC/MC/PC/UC48	1.00	1.00	1.00
-	FC/MC/PC/UC60	1.00	1.00	1.00
-	HC42	1.00	1.00	1.00
-	HD36	0.98	0.98	1.00
-	MH36S	1.00	0.98	1.00

Variable Speed Furnace	Coil	T.C.	S.C.	KW
(F,L)C9V*B12	FC/MC/PC35B	1.00	1.02	0.96
(F,L)C8V*B16	FC/MC/PC35B	1.00	1.02	0.96
(F,L)C8V*C16	FC/MC/PC35C	1.00	1.02	0.92
(F,L)C9V*C16	FC/MC/PC35C	1.00	1.02	0.92
(F,L)C9V*B12	FC/MC/PC42B	1.00	1.02	0.96
(F,L)C8V*B16	FC/MC/PC42B	1.00	1.02	0.96
(F,L)C8V*C16	FC/MC/PC42C	1.00	1.02	0.92
(F,L)C9V*C16	FC/MC/PC42C	1.00	1.02	0.92
(F,L)C8V*C16	FC/MC/PC48C	1.00	1.02	0.92
(F,L)C9V*C16	FC/MC/PC48C	1.00	1.02	0.92
(F,L)C9V*C16	FC/PC60C	1.00	1.02	0.92
(F,L)C8V*C16	FC/PC60C	1.00	1.02	0.92
(F,L)C9V*C16	HC42	1.00	1.02	0.96
(F,L)C8V*C16	HC42	1.00	1.02	0.96
(F,L)C8V*C20	HC42	1.00	1.02	0.92
(F,L)C9V*C16	HD36	1.00	1.02	0.96
(F,L)C8V*C16	HD36	1.00	1.02	0.96
(F,L)C8V*C20	HD36	1.00	1.02	0.92

COOLING PERFORMANCE DATA										
AIR CONDITIONER MODEL NO.		FRHS0361CD								
INDOOR COIL MODEL NO.		FC/MC60D + MA14D								
CONDENSER ENTERING AIR TEMPERATURE	ID CFM	1000			1200			1400		
	ID DB (°F)	85	80	70	85	80	70	85	80	70
	ID WB (°F)	72	67	57	72	67	57	72	67	57
75	T.C.	41.8	38.9	35.7	42.1	39.9	36.9	42.4	40.9	38.1
	S.C.	26.8	25.8	24.5	28.2	28.2	26.9	29.7	30.6	29.3
	KW	2.39	2.38	2.37	2.46	2.45	2.44	2.54	2.53	2.52
85	T.C.	39.8	37.1	34.0	40.3	38.0	35.0	40.7	38.9	36.1
	S.C.	26.1	25.1	23.7	27.7	27.4	26.1	29.4	29.8	28.4
	KW	2.66	2.65	2.64	2.74	2.73	2.72	2.81	2.80	2.79
95	T.C.	37.9	35.2	32.2	38.4	36.0	33.2	39.0	36.8	34.1
	S.C.	25.3	24.4	23.0	27.2	26.6	25.2	29.2	28.9	27.5
	KW	2.94	2.92	2.91	3.02	3.00	2.99	3.09	3.07	3.06
105	T.C.	36.0	33.5	30.6	36.7	34.2	31.4	37.3	34.9	32.2
	S.C.	24.6	23.8	22.4	26.8	26.0	24.6	29.0	28.2	26.8
	KW	3.21	3.19	3.19	3.29	3.27	3.26	3.36	3.35	3.34
115	T.C.	34.1	31.7	28.9	34.9	32.3	29.6	35.7	32.9	30.3
	S.C.	24.0	23.1	21.8	26.4	25.3	24.0	28.9	27.4	26.2
	KW	3.49	3.47	3.47	3.56	3.55	3.54	3.64	3.62	3.61
125	T.C.	32.2	30.0	27.3	33.1	30.5	27.9	34.1	30.9	28.4
	S.C.	23.3	22.5	21.2	26.0	24.6	23.4	28.8	26.7	25.5
	KW	3.77	3.75	3.75	3.83	3.83	3.82	3.92	3.89	3.88

NOTE: ALL CAPACITIES INCLUDE INDOOR FAN HEAT AT 1250 BTUH/1000 CFM.

Multipliers for determining the performance with other indoor sections.

NOTE: For dry bulb temperatures different than those listed (between 73-87 F), sensible capacity increases by 1060 BTUH per 1000 CFM per degree above the listed temperature and decreases by 1060 BTUH per 1000 CFM per degree below the listed temperature.

Air Handler	Coil	T.C.	S.C.	KW
MA12B	FC/MC35B	0.97	0.97	1.00
MA12B	FC/MC42B	0.97	0.97	1.00
MA14D	FC/MC48D	1.00	1.00	1.00
AHP42	-	0.97	0.97	1.00
AHP/SHP60	-	1.00	1.01	0.92
F*FP045	-	1.00	1.10	0.88
MV12B	FC/MC35B	0.98	0.98	1.00
MV12B	FC/MC42B	0.98	0.98	1.00
MV16C	FC/MC48C	1.00	1.01	0.96
MV20D	FC/MC48D	1.00	1.01	0.92
MV20D	FC/MC60D	1.00	1.03	0.92
MV16C	FC60C	1.00	1.01	0.96
AV36	-	1.00	0.98	0.92
AV/SV48	-	1.00	1.01	0.96
F*FV060	-	1.00	1.01	0.96
-	FC/MC/PC35	0.97	0.97	1.00
-	FC/MC/PC/UC42	0.97	0.97	1.00
-	FC/MC/PC/UC48	1.00	1.00	1.00
-	FC/MC/PC/UC60	1.00	1.00	1.00
-	HC42	0.99	0.99	1.00
-	HC60	0.98	0.98	1.00
-	HD48	0.99	0.99	1.00
-	MH42S	0.96	0.96	1.00

Variable Speed Furnace *	Coil	T.C.	S.C.	KW
(F,L)C9V*B12	FC/MC/PC35B	0.99	1.01	0.96
(F,L)C8V*B16	FC/MC/PC35B	0.98	1.01	1.00
(F,L)C9V*C16	FC/MC/PC35C	0.98	1.01	1.00
(F,L)C9V*C20	FC/MC/PC35C	0.98	1.01	1.00
(F,L)C8V*C16	FC/MC/PC35C	0.99	1.01	0.96
(F,L)C8V*C20	FC/MC/PC35C	0.99	1.01	0.96
(F,L)C9V*B12	FC/MC/PC42B	0.99	1.01	0.96
(F,L)C8V*B16	FC/MC/PC42B	0.98	1.01	1.00
(F,L)C9V*C16	FC/MC/PC42C	0.98	1.01	1.00
(F,L)C9V*C20	FC/MC/PC42C	0.98	1.01	1.00
(F,L)C8V*C16	FC/MC/PC42C	0.99	1.01	0.96
(F,L)C8V*C20	FC/MC/PC42C	0.99	1.01	0.96
(F,L)C9V*C16	FC/MC/PC48C	1.00	1.01	0.92
(F,L)C9V*C20	FC/MC/PC48C	1.00	1.01	0.92
(F,L)C8V*C16	FC/MC/PC48C	1.00	1.01	0.92
(F,L)C8V*C20	FC/MC/PC48C	1.00	1.01	0.92
(F,L)C9V*D20	FC/MC/PC48D	1.00	1.01	0.96
(F,L)C9V*D20	FC/MC/PC60D	1.00	1.01	0.92
(F,L)C9V*C16	FC/PC60C	1.00	1.01	0.92
(F,L)C9V*C20	FC/PC60C	1.00	1.01	0.92
(F,L)C8V*C16	FC/PC60C	1.00	1.01	0.92
(F,L)C8V*C20	FC/PC60C	1.00	1.01	0.92
(F,L)C9V*C16	HC42	1.00	1.01	0.96
(F,L)C9V*C20	HC42	1.00	1.01	0.96
(F,L)C8V*C16	HC42	1.00	1.01	0.96
(F,L)C8V*C20	HC42	1.00	1.01	0.96
(F,L)C9V*D20	HC60	1.00	1.01	0.92
(F,L)C9V*C16	HD48	1.00	1.01	0.96
(F,L)C9V*C20	HD48	1.00	1.01	0.96
(F,L)C8V*C16	HD48	1.00	1.01	0.96
(F,L)C8V*C20	HD48	1.00	1.01	0.96

COOLING PERFORMANCE DATA										
AIR CONDITIONER MODEL NO.		FRHS0421CD								
INDOOR COIL MODEL NO.		AHP/SHP48								
CONDENSER ENTERING AIR TEMPERATURE	ID CFM	1200			1400			1600		
	ID DB (°F)	85	80	70	85	80	70	85	80	70
	ID WB (°F)	72	67	57	72	67	57	72	67	57
75	T.C.	48.9	45.6	42.1	49.9	46.9	43.0	50.9	48.2	43.9
	S.C.	30.9	28.7	30.4	33.2	32.0	32.4	35.5	35.3	34.4
	KW	3.01	2.99	2.97	3.08	3.06	3.04	3.15	3.13	3.11
85	T.C.	46.9	43.9	40.5	47.9	44.9	41.3	48.8	45.9	42.1
	S.C.	30.2	28.5	29.5	32.5	31.2	31.7	34.9	34.0	33.9
	KW	3.31	3.29	3.27	3.38	3.36	3.34	3.45	3.43	3.41
95	T.C.	44.9	42.3	38.9	45.8	43.0	39.6	46.7	43.7	40.3
	S.C.	29.4	28.3	28.7	31.8	30.5	31.1	34.2	32.7	33.5
	KW	3.61	3.59	3.56	3.68	3.66	3.63	3.75	3.73	3.70
105	T.C.	43.0	40.4	37.1	43.7	41.0	37.7	44.4	41.6	38.3
	S.C.	28.7	27.6	27.8	31.0	29.8	30.2	33.4	31.9	32.6
	KW	4.00	3.98	3.95	4.07	4.05	4.02	4.14	4.12	4.09
115	T.C.	41.0	38.4	35.3	41.5	38.9	35.8	42.0	39.4	36.3
	S.C.	28.0	26.9	26.9	30.3	29.0	29.3	32.6	31.1	31.7
	KW	4.39	4.36	4.34	4.46	4.43	4.41	4.53	4.50	4.48
125	T.C.	39.0	36.5	33.5	39.3	36.9	33.9	39.6	37.3	34.3
	S.C.	27.2	26.2	26.1	29.5	28.3	28.5	31.7	30.3	30.9
	KW	4.78	4.75	4.73	4.85	4.82	4.80	4.92	4.89	4.87

NOTE: ALL CAPACITIES INCLUDE INDOOR FAN HEAT AT 1250 BTUH/1000 CFM.

Multipliers for determining the performance with other indoor sections.

NOTE: For dry bulb temperatures different than those listed (between 73-87 F), sensible capacity increases by 1060 BTUH per 1000 CFM per degree above the listed temperature and decreases by 1060 BTUH per 1000 CFM per degree below the listed temperature.

Air Handler	Coil	T.C.	S.C.	KW
MA16C	FC/MC48C	1.00	1.00	1.00
MA14D	FC/MC48D	1.00	1.00	1.00
MA14D	FC/MC60D	1.00	1.00	1.00
MA16C	FC60C	1.00	1.00	1.00
MA14D	MC61D	1.00	1.00	1.00
AHP/SHP60	–	1.00	1.00	0.92
MV16C	FC/MC48C	1.00	1.02	0.96
MV20D	FC/MC48D	1.00	1.02	0.96
MV20D	FC/MC60D	1.00	1.05	0.92
MV16C	FC60C	1.00	1.02	0.96
MV20D	MC61D	1.00	1.05	0.92
AV/SV48	–	1.00	1.05	0.96
F*FV060	–	1.00	1.05	0.96
–	FC/MC/PC/UC48	1.00	1.00	1.00
–	FC/MC/PC/UC60	1.00	1.00	1.00
–	HC60	1.00	1.00	1.00
–	HD60	1.00	1.00	1.00
–	MC61	1.00	1.00	1.00

Variable Speed Furnace	Coil	T.C.	S.C.	KW
(F,L)C9V*C16	FC/MC/PC48C	1.00	1.05	1.00
(F,L)C9V*C20	FC/MC/PC48C	1.00	1.05	0.96
(F,L)C8V*C16	FC/MC/PC48C	1.00	1.05	1.00
(F,L)C8V*C20	FC/MC/PC48C	1.00	1.05	1.00
(F,L)C9V*D20	FC/MC/PC48D	1.00	1.05	1.00
(F,L)C9V*D20	FC/MC/PC60D	1.00	1.05	0.96
(F,L)C9V*C16	FC/PC60C	1.00	1.05	0.96
(F,L)C9V*C20	FC/PC60C	1.00	1.05	0.96
(F,L)C8V*C16	FC/PC60C	1.00	1.05	0.96
(F,L)C8V*C20	FC/PC60C	1.00	1.05	0.96
(F,L)C9V*D20	HC60	1.00	1.05	0.96
(F,L)C8V*C20	HD60	1.00	1.05	0.96
(F,L)C9V*D20	HD60	1.00	1.05	0.96
(F,L)C9V*D20	MC61D	1.00	1.05	0.96

COOLING PERFORMANCE DATA										
AIR CONDITIONER MODEL NO.		FRHS0481BD								
INDOOR COIL MODEL NO.		FC/MC62								
CONDENSER ENTERING AIR TEMPERATURE	ID CFM	1300			1500			1700		
	ID DB (°F)	85	80	70	85	80	70	85	80	70
	ID WB (°F)	72	67	57	72	67	57	72	67	57
75	T.C.	51.8	48.4	46.0	52.2	49.3	46.5	52.6	50.1	47.0
	S.C.	33.6	32.1	31.0	35.4	34.2	33.0	37.2	36.3	35.0
	KW	3.19	3.18	3.17	3.28	3.26	3.25	3.35	3.34	3.32
85	T.C.	49.8	46.6	43.5	50.3	47.4	44.3	50.9	48.2	45.0
	S.C.	32.8	31.4	30.0	34.8	33.6	32.1	36.9	35.9	34.1
	KW	3.51	3.49	3.48	3.59	3.58	3.57	3.67	3.65	3.64
95	T.C.	47.8	44.7	41.1	48.5	45.5	42.0	49.2	46.3	42.9
	S.C.	31.9	30.7	29.0	34.3	33.0	31.1	36.6	35.4	33.3
	KW	3.83	3.81	3.80	3.91	3.89	3.88	3.99	3.96	3.95
105	T.C.	45.2	42.3	38.8	45.9	42.9	39.6	46.5	43.5	40.4
	S.C.	31.1	29.9	28.4	33.4	32.1	30.5	35.8	34.3	32.6
	KW	4.24	4.23	4.20	4.33	4.31	4.29	4.40	4.38	4.36
115	T.C.	42.6	39.8	36.5	43.2	40.2	37.1	43.8	40.7	37.8
	S.C.	30.2	29.2	27.8	32.6	31.2	29.9	35.0	33.2	32.0
	KW	4.65	4.64	4.61	4.74	4.73	4.69	4.82	4.80	4.77
125	T.C.	40.1	37.3	34.2	40.6	37.6	34.7	41.2	37.9	35.2
	S.C.	29.4	28.4	27.1	31.8	30.2	29.3	34.2	32.0	31.4
	KW	5.06	5.05	5.02	5.15	5.15	5.09	5.24	5.22	5.18

NOTE: ALL CAPACITIES INCLUDE INDOOR FAN HEAT AT 1250 BTUH/1000 CFM.

Multipliers for determining the performance with other indoor sections.

NOTE: For dry bulb temperatures different than those listed (between 73-87 F), sensible capacity increases by 1060 BTUH per 1000 CFM per degree above the listed temperature and decreases by 1060 BTUH per 1000 CFM per degree below the listed temperature.

Air Handler	Coil	T.C.	S.C.	KW
MA16C	FC/MC48C	1.00	1.00	1.00
MA20D	FC/MC48D	1.00	1.00	1.00
MA20D	FC/MC60D	1.01	1.01	1.00
MA16C	FC60C	1.01	1.01	1.00
MA20D	MC61D	1.02	1.02	1.00
AHP/SHP48	–	1.01	1.01	1.00
AHP/SHP60	–	1.01	1.01	1.00
MV20D	FC/MC48D	1.00	1.00	1.00
MV20D	FC/MC60D	1.02	1.02	0.96
MV20D	MC61D	1.03	1.03	0.96
AV/SV48	–	1.02	1.00	0.96
AV/SV60	–	1.02	1.03	0.96
F*FV060	–	1.02	1.00	0.96
–	FC/MC/PC/UC48	1.00	1.00	1.00
–	FC/MC/PC/UC60	1.01	1.01	1.00
–	HC60	1.01	1.01	1.00
–	HD60	1.01	1.01	1.00
–	MC61	1.02	1.02	1.00

Variable Speed Furnace *	Coil	T.C.	S.C.	KW
(F,L)C9V*C20	FC/MC/PC48C	1.00	1.00	1.00
(F,L)C8V*C20	FC/MC/PC48C	1.00	1.00	1.00
(F,L)C9V*D20	FC/MC/PC48D	1.00	1.00	1.00
(F,L)C9V*D20	FC/MC/PC60D	1.01	1.00	1.00
(F,L)C9V*C20	FC/PC60C	1.01	1.00	1.00
(F,L)C8V*C20	FC/PC60C	1.01	1.00	1.00
(F,L)C9V*D20	HC60	1.01	1.00	1.00
(F,L)C8V*C20	HD60	1.01	1.00	1.00
(F,L)C9V*C20	HD60	1.01	1.00	1.00
(F,L)C9V*D20	HD60	1.01	1.00	1.00
(F,L)C9V*D20	MC61D	0.99	1.00	1.00

HEATING PERFORMANCE DATA										
CONDENSING UNIT MODEL NO		FRHS0181BE								
EVAPORATOR COIL MODEL NO		FC/MC/PC36								
AIR TEMP. ENTERING OUTDOOR UNIT	AIR TEMP. ENTERING INDOOR COIL	ID CFM								
		450			600			750		
		MBTUH	KW	C.O.P.	MBTUH	KW	C.O.P.	MBTUH	KW	C.O.P.
60	60	21.7	4.6	1.4	22.9	5.1	1.3	24.0	5.7	1.2
	70	20.0	4.1	1.4	21.1	4.5	1.4	22.2	5.0	1.3
	80	18.3	3.7	1.5	19.4	4.0	1.4	20.5	4.4	1.4
47	60	17.8	4.2	1.3	18.4	4.5	1.2	19.0	4.8	1.2
	70	16.3	3.7	1.3	17.1	4.0	1.2	17.9	4.4	1.2
	80	14.9	3.3	1.3	15.9	3.6	1.3	16.9	4.0	1.2
40	60	15.9	4.0	1.2	16.4	4.2	1.1	17.0	4.5	1.1
	70	14.2	3.5	1.2	14.8	3.7	1.2	15.4	3.9	1.1
	80	12.6	3.0	1.2	13.2	3.2	1.2	13.8	3.5	1.2
30	60	10.5	3.3	0.9	11.2	3.6	0.9	11.9	3.9	0.9
	70	10.8	3.1	1.0	11.3	3.3	1.0	11.8	3.5	1.0
	80	11.1	2.9	1.1	11.4	3.0	1.1	11.7	3.1	1.1
17	60	7.4	2.5	0.9	7.7	2.6	0.9	8.1	2.8	0.9
	70	7.6	2.3	1.0	8.1	2.5	1.0	8.6	2.6	0.9
	80	7.7	2.1	1.1	8.4	2.3	1.1	9.0	2.5	1.0
10	60	9.1	2.7	1.0	9.3	2.9	1.0	9.4	3.0	0.9
	70	7.7	2.2	1.0	7.9	2.3	1.0	8.2	2.5	1.0
	80	6.2	1.7	1.1	6.5	1.8	1.0	6.9	2.0	1.0

NOTE: ALL CAPACITIES ARE NET (KBTUH) WITH INDOOR FAN HEAT ALREADY DEDUCTED AT 1250 BTUH/1000 CFM.

Multipliers for determining the performance with other indoor sections.

Air Handler	Coil	T.C.	S.C.	KW
MA08B	FC/MC36B	1.00	1.00	1.00
AHP24	–	1.00	1.00	1.00
MV12B	FC/MC36B	0.99	1.09	0.91
AV24	–	0.99	1.09	0.91
–	HC36	1.00	1.00	1.00
–	HD36	1.00	1.00	1.00
–	MH30S	1.00	1.00	1.00

Variable Speed Furnace *	Coil	T.C.	S.C.	KW
(F,L)C8V*A12	FC/MC/PC36A	0.99	1.09	0.91
(F,L)C9V*B12	FC/MC/PC36B	0.99	1.09	0.91
(F,L)C9V*A12	FC/MC/PC36B	0.99	1.09	0.91
(F,L)C9V*B12	HC36	0.99	1.09	0.91
(F,L)C9V*B12	HD36	0.99	1.09	0.91

HEATING PERFORMANCE DATA										
CONDENSING UNIT MODEL NO		FRHS0241CD								
EVAPORATOR COIL MODEL NO		FC/MC/PC/UC48								
AIR TEMP. ENTERING OUTDOOR UNIT	AIR TEMP. ENTERING INDOOR COIL	ID CFM								
		600			800			1000		
		MBTUH	KW	C.O.P.	MBTUH	KW	C.O.P.	MBTUH	KW	C.O.P.
60	60	28.2	1.84	4.50	29.1	1.76	4.84	29.9	1.69	5.18
	70	26.8	2.00	3.94	27.8	1.91	4.27	28.8	1.83	4.61
	80	25.4	2.21	3.36	26.5	2.10	3.70	27.7	2.01	4.04
47	60	24.8	1.78	4.08	25.2	1.73	4.26	25.6	1.69	4.44
	70	23.4	1.95	3.53	24.0	1.88	3.74	24.5	1.81	3.97
	80	22.0	2.17	2.98	22.8	2.06	3.23	23.5	1.97	3.49
40	60	22.1	1.75	3.70	23.1	1.72	3.94	24.1	1.69	4.18
	70	21.0	1.90	3.24	21.9	1.86	3.45	22.8	1.82	3.67
	80	19.9	2.11	2.78	20.7	2.05	2.97	21.5	1.99	3.17
30	60	19.6	1.69	3.41	20.0	1.67	3.51	20.4	1.66	3.61
	70	18.3	1.84	2.92	18.9	1.81	3.07	19.5	1.78	3.22
	80	17.0	2.05	2.43	17.8	1.98	2.63	18.6	1.93	2.83
17	60	15.6	1.60	2.86	16.1	1.61	2.94	16.6	1.61	3.02
	70	14.5	1.73	2.46	15.0	1.73	2.54	15.6	1.73	2.64
	80	13.5	1.91	2.07	14.0	1.89	2.17	14.5	1.87	2.27
10	60	13.7	1.54	2.61	14.0	1.55	2.64	14.2	1.57	2.66
	70	12.6	1.66	2.23	13.0	1.67	2.28	13.3	1.68	2.33
	80	11.5	1.82	1.85	11.9	1.82	1.93	12.4	1.81	2.00

NOTE: ALL CAPACITIES ARE NET WITH INDOOR FAN HEAT ALREADY DEDUCTED AT 1250 BTUH/1000 CFM.

Multipliers for determining the performance with other indoor sections.

Air Handler	Coil	MBH	KW	COP
MA08B	FC/MC35B	0.99	0.97	1.02
MA08B	FC/MC42B	0.99	0.97	1.02
AHP30	–	0.99	0.97	1.02
MV12B	FC/MC35B	0.97	1.03	0.94
MV12B	FC/MC42B	0.97	1.03	0.94
AV36	–	0.97	0.98	0.99
–	FC/MC/PC35	0.99	0.97	1.02
–	FC/MC/PC/UC42	0.99	0.97	1.02
–	FC/MC/PC/UC48	1.00	1.02	0.98
–	HC42	0.99	0.97	1.02
–	HD36	0.99	0.97	1.02
–	MH30S	0.99	0.97	1.02

Variable Speed Furnace	Coil	MBH	KW	COP
(F,L)C9V*B12	FC/MC/PC35	0.97	1.03	0.94
(F,L)C9V*B12	FC/MC/PC42	0.97	1.03	0.94
(F,L)C9V*B12	HD36	0.98	1.03	0.94

HEATING PERFORMANCE DATA										
CONDENSING UNIT MODEL NO		FRHS0301CD								
EVAPORATOR COIL MODEL NO		FC/MC48D + MA14D								
AIR TEMP. ENTERING OUTDOOR UNIT	AIR TEMP. ENTERING INDOOR COIL	ID CFM								
		800			1000			1200		
		MBTUH	KW	C.O.P.	MBTUH	KW	C.O.P.	MBTUH	KW	C.O.P.
60	60	35.1	2.54	4.04	35.5	2.46	4.23	36.0	2.38	4.44
	70	35.1	2.79	3.69	35.6	2.69	3.88	36.1	2.60	4.08
	80	35.2	3.05	3.39	35.8	2.94	3.57	36.4	2.83	3.77
47	60	30.5	2.46	3.64	31.3	2.41	3.81	32.0	2.35	3.98
	70	30.5	2.71	3.31	31.0	2.64	3.45	31.5	2.57	3.60
	80	30.6	2.96	3.03	30.9	2.88	3.14	31.2	2.80	3.27
40	60	28.6	2.39	3.51	29.0	2.37	3.58	29.3	2.35	3.65
	70	28.4	2.64	3.16	28.6	2.60	3.22	28.7	2.56	3.28
	80	28.4	2.89	2.87	28.2	2.84	2.92	28.1	2.78	2.96
30	60	24.2	2.31	3.07	25.7	2.32	3.24	27.2	2.33	3.42
	70	24.6	2.56	2.82	25.0	2.55	2.88	25.4	2.53	2.94
	80	25.2	2.82	2.62	24.4	2.78	2.58	23.7	2.74	2.54
17	60	21.1	2.22	2.78	21.4	2.23	2.82	21.7	2.24	2.85
	70	20.1	2.45	2.41	20.4	2.45	2.45	20.7	2.44	2.49
	80	19.2	2.68	2.10	19.5	2.66	2.15	19.8	2.64	2.20
10	60	18.8	2.14	2.58	19.1	2.17	2.58	19.4	2.20	2.59
	70	17.8	2.37	2.20	18.0	2.38	2.22	18.1	2.39	2.23
	80	16.8	2.59	1.91	16.9	2.58	1.92	16.9	2.56	1.93

NOTE: ALL CAPACITIES ARE NET WITH INDOOR FAN HEAT ALREADY DEDUCTED AT 1250 BTUH/1000 CFM.

Multipliers for determining the performance with other indoor sections.

Air Handler	Coil	T.C.	S.C.	KW
MA12B	FC/MC35B	1.00	0.89	1.12
MA12B	FC/MC42B	1.00	0.89	1.12
AHP36	–	1.00	0.89	1.12
MV12B	FC/MC35B	1.00	0.94	1.07
MV16C	FC/MC35C	1.00	0.94	1.07
MV12B	FC/MC42B	1.00	0.94	1.07
MV16C	FC/MC42C	1.00	0.94	1.07
MV16C	FC/MC48C	1.00	1.05	0.95
MV16C	FC60C	0.99	1.06	0.93
AV36	–	1.00	0.94	1.07
–	FC/MC/PC35	1.00	0.89	1.12
–	FC/MC/PC/UC42	1.00	0.89	1.12
–	FC/MC/PC/UC48	1.00	1.00	1.00
–	FC/MC/PC/UC60	1.00	1.00	1.00
–	HC42	1.00	0.93	1.08
–	HD36	1.00	0.93	1.08
–	MH36S	1.00	0.89	1.16

Variable Speed Furnace *	Coil	T.C.	S.C.	KW
(F,L)C9V*B12	FC/MC/PC35B	1.00	0.94	1.07
(F,L)C8V*B16	FC/MC/PC35B	1.00	0.94	1.07
(F,L)C8V*C16	FC/MC/PC35C	0.99	0.94	1.07
(F,L)C9V*C16	FC/MC/PC35C	0.99	0.94	1.07
(F,L)C9V*B12	FC/MC/PC42B	1.00	0.94	1.07
(F,L)C8V*B16	FC/MC/PC42B	1.00	0.94	1.07
(F,L)C8V*C16	FC/MC/PC42C	0.99	0.94	1.07
(F,L)C9V*C16	FC/MC/PC42C	0.99	0.94	1.07
(F,L)C8V*C16	FC/MC/PC48C	1.00	0.94	1.07
(F,L)C9V*C16	FC/MC/PC48C	1.00	0.94	1.07
(F,L)C9V*C16	FC/PC60C	1.00	0.94	1.07
(F,L)C8V*C16	FC/PC60C	1.00	0.94	1.07
(F,L)C9V*C16	HC42	1.00	0.94	1.07
(F,L)C8V*C16	HC42	1.00	0.94	1.07
(F,L)C8V*C20	HC42	1.00	0.94	1.07
(F,L)C9V*C16	HD36	1.00	0.94	1.07
(F,L)C8V*C16	HD36	1.00	0.94	1.07
(F,L)C8V*C20	HD36	1.00	0.94	1.07

HEATING PERFORMANCE DATA										
CONDENSING UNIT MODEL NO		FRHS0361CD								
EVAPORATOR COIL MODEL NO		FC/MC60D + MA14D								
AIR TEMP. ENTERING OUTDOOR UNIT	AIR TEMP. ENTERING INDOOR COIL	ID CFM								
		1000			1200			1400		
		MBTUH	KW	C.O.P.	MBTUH	KW	C.O.P.	MBTUH	KW	C.O.P.
60	60	41.7	2.90	4.22	42.9	2.84	4.44	44.2	2.78	4.65
	70	43.7	3.04	4.21	45.2	3.16	4.19	46.6	2.93	4.67
	80	43.5	3.43	3.72	45.1	3.35	3.95	46.7	3.28	4.17
47	60	36.8	2.83	3.81	37.3	2.78	3.93	37.8	2.73	4.06
	70	38.0	2.98	3.74	38.5	2.93	3.85	39.0	2.88	3.97
	80	37.7	3.36	3.29	38.1	3.29	3.40	38.5	3.22	3.51
40	60	33.8	2.77	3.57	34.2	2.74	3.67	34.7	2.71	3.76
	70	34.4	2.92	3.45	34.9	2.89	3.54	35.3	2.85	3.63
	80	33.9	3.29	3.03	34.3	3.24	3.11	34.7	3.19	3.19
30	60	29.5	2.69	3.21	30.0	2.69	3.27	30.4	2.68	3.33
	70	29.2	2.93	2.92	29.8	2.83	3.09	30.4	2.73	3.26
	80	28.3	3.19	2.60	29.0	3.17	2.68	29.7	3.15	2.76
17	60	23.9	2.57	2.73	24.4	2.58	2.77	24.9	2.60	2.81
	70	22.5	2.71	2.44	23.2	2.72	2.50	23.9	2.73	2.56
	80	21.2	3.02	2.05	22.0	3.03	2.14	22.9	3.03	2.22
10	60	21.0	2.49	2.48	21.4	2.52	2.49	21.8	2.54	2.51
	70	19.2	2.62	2.15	19.6	2.64	2.18	20.1	2.65	2.22
	80	17.8	2.92	1.79	18.3	2.92	1.84	18.8	2.92	1.89

NOTE: ALL CAPACITIES ARE NET WITH INDOOR FAN HEAT ALREADY DEDUCTED AT 1250 BTUH/1000 CFM.

Multipliers for determining the performance with other indoor sections.

Air Handler	Coil	T.C.	S.C.	KW
MA12B	FC/MC35B	1.00	0.95	1.05
MA12B	FC/MC42B	1.00	0.95	1.05
MA14D	FC/MC48D	1.00	1.00	1.00
MA14D	FC/MC60D	1.00	1.00	1.00
AHP42	–	1.00	0.95	1.05
AHP/SHP60	–	1.00	0.99	1.04
F*FP045	–	1.00	0.99	1.04
MV12B	FC/MC35B	1.00	0.97	1.03
MV12B	FC/MC42B	1.00	0.97	1.03
MV16C	FC/MC48C	1.00	1.07	0.94
MV20D	FC/MC48D	1.00	1.07	0.94
MV20D	FC/MC60D	1.00	1.00	1.00
MV16C	FC60C	1.00	1.07	0.94
AV36	–	1.00	0.97	1.03
AV/SV48	–	1.00	0.97	1.03
F*FV060	–	1.00	0.97	1.03
–	FC/MC/PC35	1.00	0.95	1.05
–	FC/MC/PC/UC42	1.00	0.95	1.05
–	FC/MC/PC/UC48	1.00	1.00	1.00
–	FC/MC/PC/UC60	1.00	1.00	1.00
–	HC42	1.00	0.96	1.04
–	HC60	1.00	1.00	1.00
–	HD48	1.00	0.96	1.04
–	MH42S	1.00	0.94	1.11

Variable Speed Furnace *	Coil	T.C.	S.C.	KW
(F,L)C9V*B12	FC/MC/PC42B	1.00	1.07	0.94
(F,L)C8V*B16	FC/MC/PC42B	1.00	1.07	0.94
(F,L)C9V*C16	FC/MC/PC42C	1.00	1.07	0.94
(F,L)C9V*C20	FC/MC/PC42C	1.00	1.07	0.94
(F,L)C8V*C16	FC/MC/PC42C	1.00	1.07	0.94
(F,L)C8V*C20	FC/MC/PC42C	1.00	1.07	0.94
(F,L)C9V*C16	FC/MC/PC48C	1.00	1.07	0.94
(F,L)C9V*C20	FC/MC/PC48C	1.00	1.07	0.94
(F,L)C8V*C16	FC/MC/PC48C	1.00	1.07	0.94
(F,L)C8V*C20	FC/MC/PC48C	1.00	1.07	0.94
(F,L)C9V*D20	FC/MC/PC48D	1.00	1.07	0.94
(F,L)C9V*D20	FC/MC/PC60D	1.00	1.07	0.94
(F,L)C9V*C16	FC/PC60C	1.00	1.07	0.94
(F,L)C9V*C20	FC/PC60C	1.00	1.07	0.94
(F,L)C8V*C16	FC/PC60C	1.00	1.07	0.94
(F,L)C8V*C20	FC/PC60C	1.00	1.07	0.94
(F,L)C9V*C16	HC42	1.00	1.07	0.94
(F,L)C9V*C20	HC42	1.00	1.07	0.94
(F,L)C8V*C16	HC42	1.00	1.07	0.94
(F,L)C8V*C20	HC42	1.00	1.07	0.94
(F,L)C9V*D20	HC60	1.00	1.07	0.94
(F,L)C9V*C16	HD48	1.00	1.07	0.94
(F,L)C9V*C20	HD48	1.00	1.07	0.94
(F,L)C8V*C16	HD48	1.00	1.07	0.94
(F,L)C8V*C20	HD48	1.00	1.07	0.94

HEATING PERFORMANCE DATA										
CONDENSING UNIT MODEL NO		FRHS0421CD								
EVAPORATOR COIL MODEL NO		AHP/SHP48								
AIR TEMP. ENTERING OUTDOOR UNIT	AIR TEMP. ENTERING INDOOR COIL	ID CFM								
		1200			1400			1600		
		MBTUH	KW	C.O.P.	MBTUH	KW	C.O.P.	MBTUH	KW	C.O.P.
60	60	49.3	3.19	4.53	50.1	3.15	4.66	51.0	3.11	4.80
	70	49.4	3.62	4.00	50.4	3.56	4.14	51.3	3.52	4.28
	80	47.3	4.04	3.43	48.4	3.97	3.57	49.4	3.91	3.71
47	60	43.6	2.97	4.31	43.6	3.04	4.21	43.6	3.11	4.11
	70	43.0	3.37	3.74	43.5	3.40	3.75	44.0	3.43	3.76
	80	40.8	3.82	3.13	41.8	3.77	3.25	42.8	3.73	3.37
40	60	39.5	2.94	3.93	40.2	2.93	4.02	40.9	2.92	4.11
	70	39.2	3.28	3.50	39.9	3.26	3.59	40.7	3.25	3.67
	80	37.6	3.62	3.05	38.4	3.60	3.12	39.2	3.59	3.20
30	60	34.2	2.88	3.48	34.8	2.88	3.54	35.3	2.89	3.59
	70	33.5	3.17	3.10	34.3	3.17	3.17	35.0	3.17	3.24
	80	32.1	3.49	2.69	33.0	3.48	2.78	34.0	3.47	2.87
17	60	27.8	2.71	3.01	28.0	2.73	3.01	28.2	2.75	3.01
	70	26.7	2.92	2.68	27.2	2.93	2.72	27.7	2.95	2.75
	80	25.5	3.18	2.34	26.2	3.19	2.41	27.0	3.19	2.48
10	60	23.9	2.61	2.68	24.3	2.64	2.70	24.7	2.66	2.72
	70	23.3	2.77	2.47	23.3	2.79	2.45	23.3	2.80	2.43
	80	23.0	2.99	2.25	22.5	3.01	2.20	22.1	3.02	2.14

NOTE: ALL CAPACITIES ARE NET WITH INDOOR FAN HEAT ALREADY DEDUCTED AT 1250 BTUH/1000 CFM.

Multipliers for determining the performance with other indoor sections.

Air Handler	Coil	T.C.	S.C.	KW
MA16C	FC/MC48C	1.00	1.02	0.98
MA14D	FC/MC48D	1.00	1.02	0.98
MA14D	FC/MC60D	1.00	1.00	1.00
MA16C	FC60C	1.00	1.00	1.00
MA14D	MC61D	1.00	0.97	1.03
AHP/SHP48	–	1.00	1.00	1.00
AHP/SHP60	–	1.00	1.00	1.00
MV16C	FC/MC48C	1.00	1.04	0.96
MV20D	FC/MC48D	1.00	1.04	0.96
MV20D	FC/MC60D	1.00	1.05	0.95
MV16C	FC60C	1.00	1.04	0.96
MV20D	MC61D	1.00	1.05	0.95
AV/SV48	–	1.00	1.04	0.96
F*FV060	–	1.00	1.04	0.96
–	FC/MC/PC/UC48	1.00	1.02	0.98
–	FC/MC/PC/UC60	1.00	1.00	1.00
–	HC60	1.00	1.00	1.00
–	HD60	1.00	1.00	1.00
–	MC61	1.00	0.97	1.03

Variable Speed Furnace *	Coil	T.C.	S.C.	KW
(F,L)C9V*C16	FC/MC/PC48C	1.00	1.04	0.96
(F,L)C9V*C20	FC/MC/PC48C	1.00	1.04	0.96
(F,L)C8V*C16	FC/MC/PC48C	1.00	1.04	0.96
(F,L)C8V*C20	FC/MC/PC48C	1.00	1.04	0.96
(F,L)C9V*D20	FC/MC/PC48D	1.00	1.04	0.96
(F,L)C9V*D20	FC/MC/PC60D	1.00	1.04	0.96
(F,L)C9V*C16	FC/PC60C	1.00	1.04	0.96
(F,L)C9V*C20	FC/PC60C	1.00	1.04	0.96
(F,L)C8V*C16	FC/PC60C	1.00	1.04	0.96
(F,L)C8V*C20	FC/PC60C	1.00	1.04	0.96
(F,L)C9V*D20	HC60	1.00	1.04	0.96
(F,L)C8V*C20	HD60	1.00	1.04	0.96
(F,L)C9V*D20	HD60	1.00	1.04	0.96
(F,L)C9V*D20	MC61D	1.00	1.04	0.96

HEATING PERFORMANCE DATA										
CONDENSING UNIT MODEL NO		FRHS0481BD								
EVAPORATOR COIL MODEL NO		FC/MC62								
AIR TEMP. ENTERING OUTDOOR UNIT	AIR TEMP. ENTERING INDOOR COIL	ID CFM								
		1300			1500			1700		
		MBTUH	KW	C.O.P.	MBTUH	KW	C.O.P.	MBTUH	KW	C.O.P.
60	60	52.7	3.70	4.17	54.3	3.63	4.39	55.8	3.56	4.60
	70	51.3	3.97	3.79	53.0	3.89	3.99	54.7	3.82	4.20
	80	50.2	4.46	3.30	52.1	4.36	3.50	54.0	4.27	3.71
47	60	46.0	3.59	3.75	46.6	3.53	3.87	47.3	3.47	3.99
	70	44.9	3.86	3.41	45.5	3.79	3.52	46.0	3.72	3.62
	80	44.1	4.32	2.99	44.5	4.22	3.09	45.0	4.14	3.19
40	60	41.9	3.51	3.51	42.5	3.46	3.60	43.1	3.42	3.69
	70	40.9	3.77	3.18	41.4	3.72	3.26	41.9	3.67	3.34
	80	40.0	4.19	2.79	40.4	4.13	2.87	40.9	4.07	2.95
30	60	36.1	3.37	3.14	36.6	3.36	3.20	37.2	3.36	3.25
	70	34.9	3.74	2.73	35.6	3.62	2.88	36.2	3.49	3.05
	80	33.8	4.01	2.47	34.6	3.99	2.54	35.4	3.96	2.62
17	60	28.4	3.16	2.64	29.0	3.18	2.68	29.6	3.20	2.72
	70	27.2	3.40	2.34	28.0	3.42	2.40	28.8	3.44	2.46
	80	25.9	3.72	2.05	27.0	3.72	2.13	28.1	3.73	2.21
10	60	24.5	3.01	2.38	24.9	3.05	2.40	25.3	3.08	2.41
	70	23.4	3.26	2.10	23.9	3.28	2.14	24.4	3.30	2.17
	80	22.3	3.53	1.85	22.9	3.54	1.90	23.6	3.54	1.95

NOTE: ALL CAPACITIES ARE NET WITH INDOOR FAN HEAT ALREADY DEDUCTED AT 1250 BTUH/1000 CFM.

Multipliers for determining the performance with other indoor sections.

Air Handler	Coil	T.C.	S.C.	KW
MA16C	FC/MC48C	1.00	1.00	1.00
MA20D	FC/MC48D	1.00	1.00	1.00
MA20D	FC/MC60D	0.99	1.01	0.98
MA16C	FC60C	0.99	1.01	0.98
MA20D	MC61D	0.98	1.08	0.00
AHP/SHP48	-	0.99	1.01	0.98
AHP/SHP60	-	0.99	1.01	0.98
MV20D	FC/MC48D	1.00	1.01	0.99
MV20D	FC/MC60D	0.98	1.03	0.95
MV20D	MC61D	0.97	1.12	0.86
AV/SV48	-	0.97	1.01	0.99
AV/SV60	-	0.97	1.01	0.99
F*FV060	-	0.97	1.01	0.99
-	FC/MC/PC/UC48	1.00	1.00	1.00
-	FC/MC/PC/UC60	0.99	1.01	0.98
-	HC60	0.99	1.01	0.98
-	HD60	0.99	1.01	0.98
-	MC61	0.98	1.08	0.90

Variable Speed Furnace *	Coil	T.C.	S.C.	KW
(F,L)C9V*C20	FC/MC/PC48C	0.98	1.01	0.99
(F,L)C8V*C20	FC/MC/PC48C	0.98	1.01	0.99
(F,L)C9V*D20	FC/MC/PC48D	0.98	1.01	0.99
(F,L)C9V*D20	FC/MC/PC60D	0.99	1.01	0.99
(F,L)C9V*C20	FC/PC60C	0.99	1.01	0.99
(F,L)C8V*C20	FC/PC60C	0.99	1.01	0.99
(F,L)C9V*D20	HC60	0.98	1.01	0.99
(F,L)C8V*C20	HD60	0.98	1.01	0.99
(F,L)C9V*C20	HD60	0.98	1.01	0.99
(F,L)C9V*D20	HD60	0.98	1.01	0.99
(F,L)C9V*D20	MC61D	1.00	1.01	0.99

Subject to change without notice. Printed in U.S.A.
Copyright © by Untiary Products Group. 2008. All rights reserved.

261176-BTG-E-0108
Supersedes: 261176-BTG-D-0107

**Unitary
Products
Group**

**5005
York
Drive**

**Norman
OK
73069**