

# SUBMITTAL DATA SHEET

## R-22 SPLIT SYSTEM HEAT PUMP UNITS

### 1.5 THRU 4 TONS

### MODELS: 14 SEER FRHS018\* Thru 048\*, 1 PHASE

JOB NAME:			LOCATION:		
PURCHASER:			ORDER NO.:		
ENGINEER:					
SUBMITTED TO:		FOR:	REF:	APPROVAL:	CONSTRUCTION:
SUBMITTED BY:			DATE:		
UNIT DESIGNATION:			SCHEDULE NO.	MODEL NO.	

### PRODUCT DATA

#### Cooling Performance

Total Capacity \_\_\_\_\_ MBH  
 Outdoor Design Temp \_\_\_\_\_ °F

#### Electrical Data

Power Supply \_\_\_\_\_ / \_\_\_\_\_ / \_\_\_\_\_  
 Total Unit Ampacity \_\_\_\_\_ AMPs  
 Power Input Req \_\_\_\_\_ KW  
 Minimum Wire Size \_\_\_\_\_ AWG  
 Overcurrent Device  
 Fuses    Circuit Breaker

#### Unit Weight

Unit Weight \_\_\_\_\_ LBS

### DIMENSIONS - INCHES

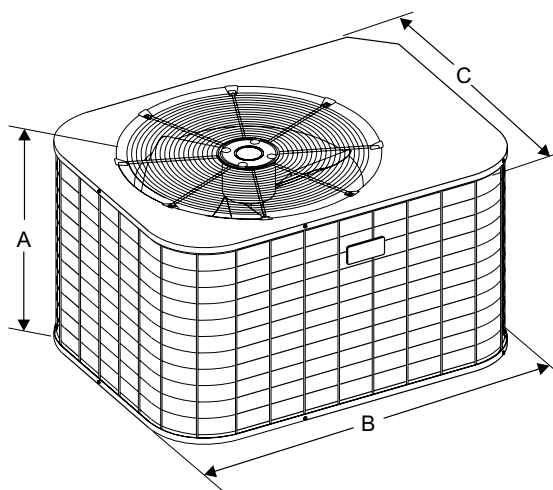

All dimensions are in inches. They are subject to change without notice. Certified dimensions will be provided upon request.

Unit Model	Dimensions (Inches)			Refrigerant Connection Service Valve Size	
	A <sup>1</sup>	B	C	Liquid	Vapor
	31	37	27	3/8	3/4
	26	43	32		7/8
	26	43	32		1-1/8
	32	43	32		
	32	43	32		
	38	43	32		

1. Including Fan Guard.



CERTIFICATION APPLIES ONLY WHEN THE COMPLETE SYSTEM IS LISTED WITH AHRI.



## FEATURES

- UL and CUL listed approval (units & accessories).
- Certified in accordance with the Unitary Small Equipment certification program, which the ARI Standard 210/240.
- 5-year limited parts warranty.
- 5-year limited warranty on the compressor.
- Copper tube aluminum fin coil.
- Internally protected compressor.
- Propeller type fan.
- Durable construction.
- Pre-painted steel cabinet.
- Factory wired and tested.
- Sweat refrigerant connections.
- Re-useable brass service valves.
- Easy access to electrical compartment.
- Liquid line filter dryer.
- PVC wire coated fan guard and enhanced protection coil guard.
- 18 gauge G90 galvanized formed base pan.
- Condenser fan molex plug connector.

## MATCHING AIR SIDE EQUIPMENT

Model No. \_\_\_\_\_  
 Submittal Form No. \_\_\_\_\_

## FIELD INSTALLED ACCESSORIES

Start Assist Kit \_\_\_\_\_  
 Blower Time Delay \_\_\_\_\_  
 Hard Start Kits - \_\_\_\_\_  
 Low Temperature Cutout \_\_\_\_\_  
 Compressor Blanket \_\_\_\_\_  
 Add-on Fossil Fuel Control \_\_\_\_\_  
 Thermal Expansion Valve Kit \_\_\_\_\_  
 Outdoor Thermostat (2TD06700124) \_\_\_\_\_

## CLEARANCES

Service Access	18 Inches
All Other Sides	10 Inches
Above Unit	48 Inches
Below Unit	0 Inches

**NOTES:**

---



---



---