

TECHNICAL GUIDE

SPLIT-SYSTEM HEAT PUMPS

10 SEER

MODELS:

**E*BA-F018 THRU 060
(1.5 THRU 5 NOMINAL TONS, 1 PH)**

**E*BA-(T,W)036 THRU 090
(3 THRU 7.5 NOMINAL TONS, 3 PH)**



MODELS: 018 - 060 (1 PH)
MODELS: 036-048 (3 PH)



MODELS: 060, 090 (3 PH)



This product was manufactured in a plant whose quality system is certified/registered as being in conformity with ISO 9001.



Certification applies only when the complete system is listed with ARI.



Due to continuous product improvement, specifications are subject to change without notice.

Visit us on the web at www.york.com for the most up-to-date technical information.

Additional rating information can be found at www.ariprimer.net.org.

DESCRIPTION

The 10 SEER Series heat pumps is the outdoor part of a versatile system of heat pumps. It is designed to be custom-matched with one of UPG's complete line of evaporator sections, with each serving a specific function. Matching Air Handlers are available for upflow, downflow, or horizontal applications to provide a complete system. Electric Heaters are available, if required. Add-On coils are available for use with upflow, downflow, or horizontal furnaces and air handlers.

WARRANTY

Single Phase Units:

5-year limited parts warranty.

5-year limited compressor warranty.

Three Phase Units:

1-year limited parts warranty.

5-year limited compressor warranty.

FEATURES

- **QUALITY COILS** - The coil is constructed of copper tube and aluminum fins.
- **COIL PROTECTION** - Coils are protected from damage by a polymer mesh applied between the coil face, and a PVC coated steel coil guard.
- **PROTECTED COMPRESSOR** - The compressor is internally protected against high pressure and temperature. This is accomplished by the simultaneous operation of high pressure relief valve and a temperature sensor which protects the compressor if undesirable operating conditions occur. A liquid line filter-drier further protects the compressor.
- **DURABLE FINISH** - Cabinet is made of pre-painted steel. The pre-treated flat galvanized steel provides a better paint to steel bond, which resists corrosion and rust creep. Special primer formulas and matted-textured finish insure less fading when exposed to sunlight.
- **LOWER INSTALLED COST** - Installation time and costs are reduced by easy power and control wiring connections. Discharge line heat exchanger knockouts are provided, if required. Available in sweat connect models only. The unit contains enough refrigerant for matching indoor coils and 15 feet of interconnecting piping. The small base dimension means less space is required on the ground or roof.
- **TOP DISCHARGE** - The warm air from the top mounted fan is blown up away from the structure and any landscaping. This allows compact location on multi-unit applications.
- **LOW OPERATING SOUND LEVEL** - The upward air flow carries the normal operating noise away from the living area. The rigid top panel effectively isolates any motor sound. Isolator mounted compressor and the rippled fins of the condenser coil muffle the normal fan motor and compressor operating sounds.
- **LOW MAINTENANCE** - Long life permanently lubricated motor-bearings need no annual servicing.
- **EASY SERVICE ACCESS** - Fully exposed refrigerant connections, a single panel covering the electrical controls, and the mox plug in the control box connecting the condenser fan make for easy servicing of the unit.
- **SECURED SERVICE VALVES** - Secured re-usable service valves are provided on both the liquid and vapor sweat connections for ease of evacuating and charging.
- **U.L. and C.U.L. listed** - approved for outdoor application.

Certified in accordance with the Unitary Small Equipment certification program, which is based on ARI Standard 210/240.

Physical and Electrical Data - 1 Phase

MODEL		EBBA-F018S	EBBA-F024S	EABA-F030S	EABA-F036S	EABA-F042S	EBBA-F048S	EABA-F060S
Unit Supply Voltage		208/230 – 1 – 60						
Normal Voltage Range ¹		187 to 252						
Minimum Circuit Ampacity		11.8	14.9	19.0	23	28.5	31.7	40.7
Max. Overcurrent Device Amps ²		20	25	30	40	40	55	60
Compressor Type ³		Recip	Recip	Recip	Recip	Recip	Scroll ^B	Scroll ^C
Compressor Amps	Rated Load	9.0	11.5	14.1	17.3	21.7	24.3	31.5
	Locked Rotor	48	60	73	94	105	140	169
Crankcase Heater		Yes	Yes	Yes	Yes	Yes	No	No
Fan Motor Amps	Rated Load	0.5	0.5	1.4	1.4	1.3	1.3	1.3
Fan Diameter Inches		18	18	18	18	22	22	22
Fan Motor	Rated HP	1/12	1/12	1/4	1/4	1/4	1/4	1/4
	Nominal RPM	1,100	1,100	1,100	1,100	850	850	850
	Nominal CFM	1,850	1,850	2,750	2,750	3,150	3,350	3,350
Coil	Face Area Sq. Ft.	9.15	12.58	12.58	12.58	15.72	19.65	23.58
	Rows Deep	1	1	1	1	1	1	1
	Fin / Inches	13	13	14	14	13	13	13
Liquid Line OD		3/8	3/8	3/8	3/8	3/8	3/8	3/8
Vapor Line OD		3/4	3/4	3/4	3/4	3/4	7/8	7/8
Unit Charge (Lbs. - Oz.) ⁴		4 - 14	5 - 0	4 - 8	5 - 12	6 - 9	8 - 3	9 - 8
Charge Per Foot, Oz.		0.68	0.68	0.68	0.68	0.68	0.70	0.70
Operating Weight Lbs.		131	141	154	159	172	204	217

Physical and Electrical Data - 3 Phase

MODEL		EABA-T036S	EBBA-T048S	EABA-T060S	EABA-T090S	EABA-W036S	EBBA-W048S	EABA-W060S	EABA-W090S
Unit Supply Voltage		208/230-3-60				460 - 3 - 60			
Normal Voltage Range ¹		187 to 252				432 to 504			
Minimum Circuit Ampacity		15.0	18.9	24.5	40.6	8.0	10.1	12.0	20.7
Max. Overcurrent Device Amps ²		25	30	40	60	15	15	20	35
Compressor Type ³		Inertia	Scroll ^B	Scroll ^C	Scroll ^C	Inertia	Scroll ^B	Scroll ^C	Scroll ^C
Compressor Amps	Rated Load	10.9	14.1	18.6	28.8	5.8	7.0	9.0	14.7
	Locked Rotor	78	125	128	195	40	55	63	95
Crankcase Heater		Yes	No	No	No	Yes	No	No	No
Fan Motor Amps	Rated Load	1.4	1.3	1.3	4.6	.8	.7	.8	2.3
Fan Diameter Inches		18	22	24	24	18	22	24	24
Fan Motor	Rated HP	1/4	1/4	1/4	3/4	1/4	1/5	1/4	3/4
	Nominal RPM	1,100	850	850	1100	1,100	825	850	1100
	Nominal CFM	2,750	3,500	3,100	5000	2,750	3,500	3,100	5000
Coil	Face Area Sq. Ft.	12.58	19.65	18.00	22.5	12.58	19.65	18.00	22.5
	Rows Deep	1	1	2	2	1	1	2	2
	Fin / Inches	14	13	14	16	14	13	14	16
Liquid Line OD		3/8	3/8	3/8	1/2	3/8	3/8	3/8	1/2
Vapor Line OD		3/4	7/8	7/8	1-1/8	3/4	7/8	7/8	1-1/8
Unit Charge (Lbs. - Oz.) ⁴		5 - 12	8 - 3	11 - 3	16	5 - 12	8 - 3	11 - 3	16
Charge Per Foot, Oz.		.68	.70	.70	1.26	.68	.70	.70	1.26
Operating Weight Lbs.		178	232	243	354	178	232	243	354

1. Rated in accordance with ARI Standard 110, utilization range "A".
2. Dual element fuses or HACR circuit breaker.
3. All scrolls listed with a superscript "B" are Bristol scrolls. All scrolls listed with a superscript "C" are Copeland scrolls.
4. The Unit Charge is correct for the outdoor unit, matched indoor coil and 15 feet of refrigerant tubing. For tubing lengths other than 15 feet, add or subtract the amount of refrigerant, using the difference in length multiplied by the per foot value.

Additional R-22 Charge / Orifice Size for Various Matched Systems - 1 Phase

Outdoor Unit	EBBA-F018S	EBBA-F024S	EABA-F030S	EABA-F036S	EABA-F042S	EBBA-F048S	EABA-F060S
Unit Orifice (s) ¹	51,53	59,61	67, 69	67, 69, 71	75,78,81	81,84,87	87
Factory R-22 Charge, lbs-oz	4 - 14	5 - 0	4 - 8	5 - 12	6 - 9	8 - 3	9 - 8

Indoor Coil	Coil Orifice ²	System Orifice - Additional Charge, Oz						
G2FD024S(H)17	61	53 + 12	59 + 9	—	—	—	—	—
G2FD030S(H)17	65	—	61 + 9	67 + 17	—	—	—	—
G2FD035S(H)14	65	—	61 + 9	67 + 17	—	—	—	—
G2FD036S(H)17/21	75	—	—	—	69 + 2	—	—	—
G2FD042S(H)21	78	—	—	—	71 + 7	—	—	—
G2FD046S(H)17	78	—	—	—	71 + 7	81 + 8	—	—
G2FD048S(H)21/24	84	—	—	—	—	81 + 15	87 + 6	—
G2FD060S(H)24	90	—	—	—	—	—	84 + 4	703 ³ + 1
G1HD024	59	53 + 13	59 + 9	—	—	—	—	—
G1HD036	69	—	—	67 + 22	69 + 4	—	—	—
G1HD048	81	—	—	—	—	81 + 10	84 + 6	—
G1HD060	93	—	—	—	—	—	84 + 0	703 ³ + 1
G1FA/G1UA024S14/17	59	53 + 10	—	—	—	—	—	—
G1FA/G1UA030S14	65	—	59 + 10	—	—	—	—	—
G1FA/G1UA036S14	73	—	—	67 + 17	—	—	—	—
G1FA/G1UA03617/21	73	—	61 + 9	67 + 15	—	—	—	—
G1FA/G1UA048S21/24	84	—	—	—	71 + 12	81 + 13	84 + 3	—
G1FA/G1UA060S24	90	—	—	—	—	—	84 + 4	703 ³ + 1
G1NA030S17H	57	53 + 0	59 + 0	69 + 0	—	—	—	—
G1NA030S21B	57	53 + 0	59 + 0	69 + 0	—	—	—	—
G1NA036S17L	71	—	—	—	67 + 7	—	—	—
G1NA048S21D	78	—	—	—	67 + 7	75 + 0	81 + 8	—
G1NA048S24P	78	—	—	—	—	75 + 0	81 + 8	—
G1NA060S24T	87	—	—	—	—	—	—	87 + 0
G1NF024SOF	63	—	59 + 0 ⁴	—	—	—	—	—
G1NF036SOF	67	—	—	69 + 0 ⁴	67 + 7 ⁴	—	—	—
G1NF048SOF	78	—	—	—	—	75 + 0 ⁴	84 + 4 ⁴	—
G1NF060SOF	87	—	—	—	—	—	—	87 + 0 ⁴
F2RP/F2FP018	53	51 + 10	—	—	—	—	—	—
F2RP/F2FP024	61	51 + 21	59 + 9	—	—	—	—	—
F2RP/F2FP030	65	—	—	69 + 19	—	—	—	—
F2RP/F2FP036	75	—	—	69 + 23	71 + 4	—	—	—
F2RP/F2FP042	78	—	—	—	71 + 7	81 + 8	—	—
F2FP048	84	—	—	—	—	81 + 15	84 + 0	—
F2FP060	90	—	—	—	—	—	87 + 4	703 ³ + 1

FOOTNOTES:

1. These orifices are packed in the customer packet of each outdoor unit.
2. These orifices are factory mounted in the flow control device of each indoor coil.
3. TXV kit must be used with these coils to obtain system performance. (701,702,703 indicates 1TV07 ...series).
4. Systems matched with furnaces or air handlers not equipped with blower-off delays, may require blower Time Delay Kit #2FD0670224.

PROCEDURES:

1. Unit factory charge listed on the unit nameplate includes refrigerant for the condenser, the smallest evaporator and for 15 feet of interconnecting line tubing.
2. Verify the orifice size and additional charge required for specific evaporator coil in the system using the above table.
3. Additional charge for the amount of interconnecting line tubing greater than 15 feet at the rate specified in the table above.
4. Permanently mark the unit nameplate with the total system charge. Total System Charge = Base Charge (as shipped) + adder for evaporator + adder for line set.
5. If the orifice in the evaporator was changed, verify the evaporator nameplate has been marked with the correct orifice size.

Additional R-22 Charge / Orifice Size for Various Matched Systems - 3 Phase

Outdoor Unit	EABA-(T,W)036S	EBBA-(T,W)048S	EABA-(T,W)060S	EABA-(T,W)090S
Unit Orifice (s) ¹	71, 75	81, 84, 87	99	—
Factory R-22 Charge, lbs-oz	5 - 12	8 - 3	11 - 3	16.0

Indoor Coil	Coil Orifice ²	System Orifice = Additional Charge, Oz			
G1NA036S17L	67	71 + 7	—	—	—
G1NA048S21D	67	71 + 7	81 + 8	—	—
G1NA048S24P	78	—	81 + 8	—	—
G1UA048S21	84	81 + 13	84 + 3	—	—
G1UA060S24	90	—	84 + 4	99 + 0	—
G1FA048S21	84	81 + 13	84 + 3	—	—
G1FA060S24	90	—	84 + 4	99 + 0	—
G2FD042(S,H)21	78	81 + 8	—	—	—
G2FD048(S,H)21/24	84	—	87 + 6	—	—
G2FD060(S,H)24	90	—	84 + 4	99 + 0	—
F3EH090A33	TXV	—	—	—	TXV ³ + 0

FOOTNOTES:

1. These orifices are packed in the instruction/warranty packet of each outdoor unit.
2. These orifices are factory mounted in the flow control device of each indoor coil.
3. A TXV is factory mounted in the coil or air handler.

PROCEDURES:

1. Unit factory charge listed on the unit nameplate includes refrigerant for the condenser, the smallest evaporator and for 15 feet of interconnecting line tubing.
2. Verify the orifice size and additional charge required for specific evaporator coil in the system using the above table.
3. Additional charge for the amount of interconnecting line tubing greater than 15 feet at the rate specified in the table above.
4. Permanently mark the unit nameplate with the total system charge. Total System Charge = Base Charge (as shipped) + adder for evaporator + adder for line set.
5. If the orifice in the evaporator was changed, verify the evaporator nameplate has been marked with the correct orifice size.

COOLING CAPACITY - With Air Handler Coils

UNIT MODEL	AIR HANDLER			COIL ¹ MODEL	COOLING					
	MODEL	ELECTRIC ² HEAT KW	W		RATED CFM	NET MBH		SEER W/O TXV	SEER WITH TXV ³	EER
						TOTAL	SENS.			
1 PH 10 SEER HP WITH N-AH / G2FD										
EBBA-F018S	N1AHB0806	2,5,8,10	17	G2FD024(S,H)17	650	17.8	12.8	10.10	-	8.95
EBBA-F024S	N1AHB0806	2,5,8,10	17	G2FD030(S,H)17	840	22.6	16.2	10.00	-	9.30
EABA-F030S	N1AHB1206	5,8,10,15,19	17	G2FD030(S,H)17	1000	28.0	19.6	10.00	-	9.10
EABA-F036S	N1AHB1206	5,8,10,15,19	17	G2FD036(S,H)17	1250	33.6	24.9	10.00	-	8.80
EABA-F042S	N1AHC1606	5,8,10,15,20	21	G2FD048(S,H)21	1400	40.0	29.6	10.10	-	9.15
EBBA-F048S	N1AHC1606	5,8,10,15,20	21	G2FD048(S,H)21	1600	45.5	33.7	10.00	-	9.45
	N1AHD2006	8,10,15,20,25,30	24	G2FD048(S,H)24	1600	45.5	33.7	10.00	-	9.45
	N1AHD2006	8,10,15,20,25,30	24	G2FD060(S,H)24	1600	46.5	34.4	10.20	-	9.60
EABA-F060S	N1AHD2006	8,10,15,20,25,30	24	G2FD060(S,H)24	1800	54.5	39.2	-	10.00	8.95
3 PH 10 SEER HP WITH N-AH / G2FD										
EABA-(T,W)036S	N1AHC1646	10,15	21	G2FD042(S,H)21	1250	34.2	25.3	10.00	-	8.95
EBBA-(T,W)048S	N1AHC1646	10,15	21	G2FD048(S,H)21	1600	45.5	33.7	10.00	-	9.45
	N1AHD2046	10,15,29	24	G2FD048(S,H)24	1600	45.5	33.7	10.00	-	9.45
EABA-(T,W)060S	N1AHD2046	10,15,29	24	G2FD060(S,H)24	1700	57.0	41.0	10.00	-	9.80
1 PH 10 SEER HP / F2RP / RC / FP / FC										
EBBA-F018S	F2RP/FP018	2,5,8	18	-	600	17.0	12.3	10.00	-	8.90
	F2RP/FP024	5,8,10	18	-	650	17.8	12.4	10.00	-	8.95
EBBA-F024S	F2RP/FP024	5,8,10	18	-	800	22.0	16.5	10.00	-	9.30
	F2RP/FP030	5,8,10,15	18	-	840	22.6	16.8	10.00	-	9.40
EABA-F030S	F2RP/FP030	5,8,10,15	18	-	1000	28.4	21.0	10.00	-	9.20
	F2RP/FP036	5,8,10,15,19	21	-	1000	29.0	20.9	10.00	-	9.40
EABA-F036S	F2RP/FP036	5,8,10,15,19	21	-	1250	34.0	24.9	10.00	-	9.00
	F2RP/FP042	5,8,10,15	21	-	1250	34.0	24.9	10.00	-	9.00
EABA-F042S	F2RP/FP042	5,8,10,15	21	-	1400	39.0	28.4	10.00	-	8.90
	F2FP048	5,8,10,15,20,25	24	-	1400	39.5	28.8	10.00	-	9.15
EBBA-F048S	F2FP048	5,8,10,15,20,25	24	-	1600	45.0	33.5	10.00	-	9.40
	F2FP060	5,8,10,15,20,25	24	-	1600	46.5	34.4	10.00	-	9.60
EABA-F060S	F2FP060	5,8,10,15,20,25	24	-	1850	54.0	40.5	-	10.00	8.60
3 PH 10 SEER HP / F2RP / RC / FP / FC^{4,5}										
EABA-(T,W)036S	F2RP/FP036	5,8,10,15,19	21	-	1250	34.0	24.9	10.00	-	9.00
	F2RP/FP042	5,8,10,15	21	-	1250	34.0	25.6	10.00	-	9.00
EBBA-(T,W)048S	F2FP048	5,8,10,15,20,25	24	-	1600	45.0	33.5	10.00	-	9.40
	F2FP060	5,8,10,15,20,25	24	-	1600	46.5	34.4	10.00	-	9.60
EABA-(T,W)060S	F2FP060	5,8,10,15,20,25	24	-	1700	56.0	40.0	10.00	-	9.40
3 PH 10 SEER HP / FHP										
EABA-(T,W)090S	FCEH090	10,16,26,36	25-1/8	-	3000	91.0	87.4	-	-	9.50

Rated in accordance with DOE test procedures (Federal Register 12-27-79 and 3-18-88) and ARI Standards 210/240.
 Cooling MBH based on 80°F entering air temperature, 50% RH, and rated air flow.
 KW includes compressor, outdoor fan and indoor blower motor watts. Add-on coils include 365 watts/1000 CFM for blower motor.
 EER (Energy Efficiency Ratio) is the total cooling output in BTU's at a 95°F outdoor ambient divided by the total electric power in watt-hours at those conditions.
 SEER (Seasonal Energy Efficiency Ratio) is the total cooling output in BTU's during a normal annual usage period for cooling divided by the total electric power input in watt-hours during the same period.

1. G2FD coils available with a factory installed horizontal drain pan. See price pages for specific model number.
2. Single phase units require single phase 2HK heaters.
3. TXV = Use 1TV700 Series Kit.
4. To meet R=4.2 insulation requirements, substitute F2FP for F2RP, and F2FC for F2RC. models. All ratings remain the same.
5. FG8, FG9, and FL8 furnaces and F2RP / F2RC air handlers have B.O.D. standard.
 - = Not applicable

COOLING CAPACITY - Upflow, Downflow, & Horizontal Furnaces and Coils

UNIT MODEL	FURNACE**		COIL MODEL	COOLING					
	CFM RANGE (MIN.-MAX.)	W		RATED CFM	NET MBH		SEER W/O TXV	SEER + TXV ¹ + TDR*	EER
					TOTAL	SENS.			
EBBA-F018S	575 725	14,17	G1FA024S14,17	650	17.6	12.7	10.00	-	8.85
		14	G1FA030S14	650	17.8	12.9	10.10	-	8.95
		-	G1HD024	650	18.0	12.9	10.10	-	9.00
		17	G1NA030S17H	650	18.0	13.5	10.00	-	9.20
		21	G1NA030S21B	650	18.0	13.5	10.00	-	9.20
		14,17	G1UA024S14,17	650	17.6	12.7	10.00	-	8.85
		14	G1UA030S14	650	17.8	12.9	10.10	-	8.95
		14,17	G2FD024(S,H)14,17	650	17.8	12.8	10.10	-	8.95
EBBA-F024S	750 950	14	G1FA030S14	830	22.2	16.4	10.00	-	9.25
		17,21	G1FA036S17,21	840	22.6	16.2	10.00	-	9.30
		-	G1HD024	800	22.2	16.4	10.00	-	9.35
		17	G1NA030S17H	850	23.0	16.1	10.00	-	9.50
		21	G1NA030S21B	850	23.0	16.1	10.00	-	9.50
		14	G1UA030S14	830	22.2	16.4	10.00	-	9.25
		17,21	G1UA036S17,21	840	22.6	16.2	10.00	-	9.30
		14,17	G2FD024(S,H)14,17	800	22.0	15.8	10.00	-	9.30
EABA-F030S	875 1125	14	G1FA036S14	1000	28.4	20.6	10.00	-	9.10
		17,21	G1FA036S17,21	1000	28.0	20.2	10.00	-	9.10
		-	G1HD036	1000	28.4	21.0	10.10	-	9.20
		17	G1NA030S17H	1050	29.0	20.6	10.00	-	9.40
		21	G1NA030S21B	1050	29.0	20.6	10.00	-	9.40
		14	G1UA036S14	1000	28.4	20.6	10.00	-	9.10
		17,21	G1UA036S17,21	1000	28.0	19.6	10.00	-	9.10
		17	G2FD030(S,H)17	1000	28.0	19.6	10.00	-	9.10
		14	G2FD035(S,H)14	1000	28.0	19.6	10.00	-	9.10
		17	G2FD036(S,H)17	1025	28.4	19.9	10.10	-	9.20
21	G2FD036(S,H)21	1000	28.6	19.9	10.15	-	9.25		
EABA-F036S	1100 1400	21,24	G1FA048S21	1250	34.4	24.7	10.00	-	9.05
		-	G1HD036	1200	33.4	24.7	10.00	-	8.85
		-	G1HD048	1200	35.2	26.0	10.00	-	9.10
		17	G1NA036S17L	1250	35.0	26.2	10.00	-	9.00
		21	G1NA048S21D	1250	35.0	26.2	10.00	-	8.95
		21,24	G1UA048S21	1250	34.4	24.7	10.00	-	9.05
		17	G2FD036(S,H)17	1250	33.6	24.9	10.00	-	8.80
		21	G2FD036(S,H)21	1200	34.0	24.5	10.00	-	9.05
		21	G2FD042(S,H)21	1250	34.2	25.3	10.00	-	8.95
EABA-(T,W)036S)	1100 1400	21,24	G1FA048S21	1250	34.4	24.7	10.00	-	9.05
		17	G1NA036S17L	1250	35.0	26.2	10.00	-	9.00
		21	G1NA048S21D	1250	35.0	26.2	10.00	-	8.95
		21,24	G1UA048S21	1250	34.4	24.7	10.00	-	9.05
		21	G2FD042S21	1250	34.2	25.3	10.00	-	8.95
EABA-F042S	1225 1575	21,24	G1FA048S21	1400	39.5	28.4	10.00	-	9.20
		-	G1HD048	1400	39.5	32.9	10.00	-	9.10
		21	G1NA048S21D	1400	40.5	28.6	10.00	-	9.50
		21,24	G1UA048S21	1400	39.5	28.4	10.00	-	9.20
		21	G2FD042(S,H)21	1400	39.0	28.9	10.00	-	9.05
		17	G2FD046(S,H)17	1400	39.5	29.3	10.00	-	9.10
		21,24	G2FD048(S,H)21,24	1400	40.0	29.6	10.10	-	9.15
24	G2FD060(S,H)24	1450	40.0	29.6	10.20	-	9.30		

For Notes see Page 5.

COOLING CAPACITY - Upflow, Downflow, & Horizontal Furnaces and Coils (Continued)

UNIT MODEL	FURNACE**		COIL MODEL	COOLING					
	CFM RANGE (MIN.-MAX.)	W		RATED CFM	NET MBH		SEER W/O TXV	SEER + TXV ¹ + TDR*	EER
					TOTAL	SENS.			
EBBA-F048S	1400 1800	21,24	G1FA048S21	1600	44.5	33.1	10.00	-	9.30
		21,24	G1FA060S21,24	1600	46.5	34.4	10.20	-	9.60
		-	G1HD048	1600	44.5	33.1	10.00	-	9.30
		-	G1HD060	1600	46.0	34.1	10.10	-	9.55
		21	G1NA048S21D	1600	43.5	32.2	10.00	-	9.25
		21,24	G1UA048S21	1600	44.5	33.1	10.00	-	9.30
		21,24	G1UA060S21,24	1600	46.5	34.4	10.20	-	9.60
		21,24	G2FD048(S,H)21,24	1600	45.5	33.7	10.00	-	9.45
EBBA-(T,W)048S)	1400 1800	21,24	G1FA048S21	1600	45.5	32.7	10.00	-	9.30
		21	G1NA048S21D	1600	45.0	31.2	10.00	-	9.50
		21,24	G1UA048S21	1600	45.5	32.7	10.00	-	9.30
		21,24	G2FD048(S,H)21,24	1600	45.5	33.7	10.00	-	9.40
EABA-F060S	1600 2100	21,24	G1FA060S21,24	1800	54.5	39.2	-	10.00	8.90
		-	G1HD060	2000	54.5	33.9	-	10.00	8.80
		24	G1NA060S24T	1850	53.5	35.5	10.00	-	9.00
		21,24	G1UA060S21,24	1800	54.5	39.2	-	10.00	8.90
		24	G2FD060(S,H)24	1800	54.5	39.2	-	10.00	8.90
EABA-(T,W)060S	1600 2100	21,24	G1FA060S21,24	1700	57.0	41.0	10.00	-	9.80
		21,24	G1UA060S21,24	1700	57.0	41.0	10.00	-	9.80
		24	G2FD060(S,H)24	1700	57.0	41.0	10.00	-	9.80

1. TXV = Use 1TV700 Series Kit.

* Requires a 2FD Blower Time Delay unless a standard furnace is equipped with one.

** Refer to Quick Selection Chart for specific furnace match-up.

HEATING PERFORMANCE - With Air Handler

UNIT MODEL*	COIL ¹ MODEL	ARI HEATING ²					OUTDOOR TEMP ³													
		47°F		17°F		HSPF	-3°F		7°F		17°F		27°F		37°F		47°F		57°F	
		MBH	COP	MBH	COP	STD	MBH	KW	MBH	KW	MBH	KW	MBH	KW	MBH	KW	MBH	KW	MBH	KW
EBBA-F018S	F2RP/F2FP018	17.0	2.96	9.1	1.78	6.80	6.2	1.43	7.4	1.46	9.1	1.50	11.2	1.61	14.0	1.62	17.0	1.68	18.2	1.75
	F2RP/F2FP024	17.0	3.00	10.6	2.06	7.00	7.2	1.44	8.6	1.47	10.6	1.52	13.0	1.63	14.0	1.59	17.0	1.66	18.2	1.73
EBBA-F024S	F2RP/F2FP024	22.0	3.20	11.5	1.88	7.00	7.5	1.56	9.3	1.66	11.5	1.78	13.0	1.87	19.4	1.91	22.0	2.00	24.8	2.08
	F2RP/F2FP030	24.0	3.16	14.0	2.06	7.30	7.7	1.52	9.6	1.62	14.0	1.74	13.4	1.83	19.8	1.90	24.0	2.00	25.4	2.07
EABA-F030S	F2RP/F2FP030	28.8	3.10	16.2	2.00	7.20	10.5	1.99	13.5	2.19	16.2	2.26	19.6	2.46	25.3	2.59	28.8	2.72	33.0	2.86
	F2RP/F2FP036	29.0	3.10	18.0	2.22	7.40	11.6	2.11	15.0	2.32	18.0	2.39	19.8	2.47	25.5	2.61	29.0	2.74	33.2	2.88
EABA-F036S	F2RP/F2FP036	34.0	3.00	20.4	2.16	7.20	15.5	2.40	15.6	2.54	20.4	2.80	24.9	3.03	29.9	3.20	34.0	3.32	38.5	3.50
	F2RP/F2FP042	34.0	3.00	20.4	2.14	7.20	11.3	2.41	15.9	2.67	20.4	2.79	25.7	3.11	31.0	3.44	34.0	3.32	38.5	3.50
EABA(T,W)036S	F2RP/F2FP036	34.0	3.00	20.4	2.16	7.20	15.5	2.40	15.6	2.54	20.4	2.80	24.9	3.03	29.9	3.20	34.0	3.32	38.5	3.50
EABA-F042S	F2RP/F2FP042	39.0	3.18	23.4	2.06	7.40	13.0	3.15	18.2	3.24	23.4	3.33	27.0	3.28	30.6	3.23	39.0	3.59	44.2	3.68
	F2FP048	39.5	3.30	23.4	2.12	7.40	12.4	2.97	17.9	3.10	23.4	3.23	28.9	3.37	32.5	3.39	39.5	3.51	47.5	3.64
EBBA-F048S	F2FP048	45.5	3.18	30.4	2.38	7.5	20.1	3.42	25.3	3.57	30.4	3.73	35.5	3.85	38.8	3.98	45.5	4.16	53.1	4.40
	F2FP060	46.0	3.24	30.4	2.38	7.5	21.3	3.44	25.3	3.63	30.4	3.75	35.9	3.84	39.2	3.97	46.0	4.16	53.6	4.40
EBBA-(T,W)048S)	F2FP048	47.0	3.08	31.4	2.32	7.50	20.8	3.64	26.1	3.80	31.4	3.97	36.7	4.13	40.1	4.27	47.0	4.47	54.6	4.71
EABA-F060S	F2FP060	57.0	3.04	37.4	2.22	7.50	24.3	4.59	30.9	4.76	37.4	4.94	44.0	5.11	48.6	5.25	57.0	5.50	67.0	5.79
EABA-(T,W)060S	F2FP060	58.5	3.12	39.0	2.34	7.60	26.0	4.48	32.5	4.68	39.0	4.88	42.1	4.98	45.1	5.07	58.5	5.49	65.0	5.70
EABA(T,W)090S	F2EH090	83.0	3.00	54.0	2.15	--	34.7	7.15	44.3	7.34	54.0	7.53	55.0	7.57	55.9	7.60	83.0	8.11	92.7	8.30

1. Rated CFM same as for cooling.

2. Heating MBH based on ARI standards of 70° DB entering indoor air, 72% RH outdoor air with 25 feet of interconnecting piping and no supplemental electric heat operation.

3. Integrated heating capacities include the effect of defrost cycles in the temperature range where they occur.

COP equals MBH output divided by (total KW input x 3.412).

HSPF (Heating Seasonal Performance Factor) is the total heating output during a normal annual usage period for heating divided by the total electric power input during the same period.

-- = Not Applicable.

HEATING PERFORMANCE - With Furnace Coils

UNIT MODEL*	COIL ¹ MODEL	ARI HEATING ²					OUTDOOR TEMP ³													
		47°F		17°F		HSP F	-3°F		7°F		17°F		27°F		37°F		47°F		57°F	
		MBH	COP	MBH	COP	STD	MBH	KW	MBH	KW	MBH	KW	MBH	KW	MBH	KW	MBH	KW	MBH	KW
EBBA-F018S	G2FD024(S,H)14,17	17.0	3.02	10.6	2.06	7.0	6.4	1.41	8.5	1.46	10.6	1.51	12.7	1.56	14.8	1.60	17.0	1.65	20.3	1.69
	G1HD024	17.2	3.04	10.6	2.06	7.0	6.2	1.41	8.4	1.46	10.6	1.51	12.4	1.59	14.3	1.67	17.2	1.66	19.4	1.71
	G1NA030S17H	17.2	2.96	10.6	2.06	7.1	6.2	1.38	8.4	1.44	10.6	1.51	12.4	1.55	14.3	1.59	17.2	1.70	19.4	1.77
	G1NA030S21B	17.2	2.96	10.6	2.06	7.1	6.2	1.38	8.4	1.44	10.6	1.51	12.4	1.55	14.3	1.59	17.2	1.70	19.4	1.77
	G1UA024S14,17	16.8	2.95	10.6	2.02	6.9	6.4	1.44	8.5	1.49	10.6	1.54	12.7	1.59	14.8	1.64	16.8	1.67	20.3	1.80
	G1FA024S14,17	16.8	2.95	10.6	2.02	6.9	6.4	1.44	8.5	1.49	10.6	1.54	12.7	1.59	14.8	1.64	16.8	1.67	20.3	1.80
EBBA-F024S	G2FD035(S,H)14	22.6	3.28	11.9	2.00	7.3	4.7	1.55	8.3	1.65	11.9	1.74	15.5	1.84	19.1	1.93	22.6	2.02	27.3	2.18
	G2FD030(S,H)17	22.6	3.28	11.9	2.00	7.3	4.7	1.55	8.3	1.65	11.9	1.74	15.5	1.84	19.1	1.93	22.6	2.02	27.3	2.18
	G2FD024(S,H)14,17	22.4	3.20	11.6	2.00	7.1	4.4	1.46	8.0	1.58	11.6	1.70	15.2	1.82	18.8	1.94	22.4	2.05	27.1	2.23
	G1HD024	22.4	3.24	11.8	2.00	7.1	4.7	1.53	8.2	1.63	11.8	1.73	15.4	1.83	18.9	1.93	22.3	2.02	27.3	2.18
	G1NA030S17H	23.4	3.28	13.3	2.10	7.4	6.1	1.63	9.5	1.72	13.0	1.81	16.0	1.92	19.0	2.03	23.4	2.09	26.9	2.18
	G1NA030S21B	23.4	3.28	13.3	2.10	7.4	6.1	1.63	9.5	1.72	13.0	1.81	16.0	1.92	19.0	2.03	23.4	2.09	26.9	2.18
	G1UA030S14	22.4	3.20	11.6	2.00	7.1	4.4	1.46	8.0	1.58	11.6	1.70	15.2	1.82	18.8	1.94	22.4	2.05	27.1	2.23
	G1UA036S17,21	22.6	3.28	11.9	2.00	7.3	4.7	1.55	8.3	1.65	11.9	1.74	15.5	1.84	19.1	1.93	22.6	2.02	27.3	2.18
	G1FA030S14	22.4	3.20	11.6	2.00	7.1	4.4	1.46	8.0	1.58	11.6	1.70	15.2	1.82	18.8	1.94	22.4	2.05	27.1	2.23
	G1FA036S17,21	22.6	3.28	11.9	2.00	7.3	4.7	1.55	8.3	1.65	11.9	1.74	15.5	1.84	19.1	1.93	22.6	2.02	27.3	2.18
EABA-F030S	G2FD030(S,H)14,17	29.0	3.08	18.0	2.20	7.4	9.4	2.08	13.7	2.24	18.0	2.40	22.3	2.56	26.9	2.71	29.0	2.76	34.6	2.98
	G2FD035(S,H)14	29.0	3.08	18.0	2.20	7.4	9.4	2.08	13.7	2.24	18.0	2.40	22.3	2.56	26.9	2.71	29.0	2.76	34.6	2.98
	G2FD036(S,H)14	29.2	3.10	18.2	2.20	7.4	10.9	2.20	14.5	2.31	18.2	2.42	21.3	2.56	24.3	2.69	29.2	2.76	32.9	2.87
	G2FD036(S,H)21	29.4	3.10	18.0	2.20	7.4	10.4	2.14	14.2	2.27	18.0	2.40	21.2	2.54	24.3	2.68	29.4	2.78	33.2	2.91
	G1HD036	29.4	3.10	18.0	2.20	7.4	9.7	2.09	13.8	2.24	18.0	2.40	22.2	2.55	26.7	2.71	29.4	2.78	33.1	2.94
	G1NA030S17H	29.0	3.06	18.0	2.22	7.4	10.7	2.11	14.3	2.24	18.0	2.38	21.5	2.50	25.0	2.62	29.0	2.78	32.7	2.91
	G1NA030S21B	29.0	3.06	18.0	2.22	7.4	10.7	2.11	14.3	2.24	18.0	2.38	21.5	2.50	25.0	2.62	29.0	2.78	32.7	2.91
	G1UA036S14	29.2	3.10	18.2	2.22	7.4	11.4	2.21	14.8	2.31	18.2	2.40	20.4	2.43	22.6	2.46	28.4	2.68	31.8	2.78
	G1UA036S17,21	29.0	3.08	18.0	2.20	7.4	9.4	2.08	13.7	2.24	18.0	2.40	22.3	2.56	26.9	2.71	29.0	2.76	34.6	2.98
	G1FA036S17,21	29.0	3.08	18.0	2.20	7.4	9.4	2.08	13.7	2.24	18.0	2.40	22.3	2.56	26.9	2.71	29.0	2.76	34.6	2.98
EABA-F036S	G2FD036(S,H)17	34.0	3.02	20.2	2.16	7.2	11.3	2.37	15.7	2.55	20.2	2.74	24.7	2.93	29.5	3.13	34.0	3.30	40.5	3.48
	G2FD036(S,H)21	33.4	2.92	19.8	2.12	7.0	11.0	2.33	15.4	2.53	19.8	2.74	24.2	2.94	28.9	3.16	33.4	3.34	39.8	3.55
	G2FD042(S,H)21	34.0	3.00	20.2	2.14	7.2	11.3	2.40	15.7	2.58	20.2	2.77	24.7	2.94	29.5	3.15	34.0	3.32	40.5	3.50
	G2FD046(S,H)17	33.6	3.00	20.0	2.14	7.2	10.9	2.38	15.5	2.56	20.0	2.74	23.8	2.91	27.6	3.08	33.6	3.28	38.1	3.46
	G1HD036	34.0	3.03	20.2	2.14	7.2	11.2	2.39	15.7	2.57	20.2	2.75	24.7	2.93	29.5	3.12	34.0	3.29	40.5	3.47
	G1HD048	34.2	3.06	20.4	2.18	7.2	11.2	2.39	15.8	2.56	20.4	2.74	24.2	2.98	28.1	3.21	34.2	3.28	38.8	3.45
	G1NA036S17L	35.0	3.20	22.0	2.26	7.6	13.3	2.62	17.7	2.74	22.0	2.85	23.3	2.71	24.5	2.57	35.0	3.21	39.3	3.32
	G1NA048S21D	35.0	3.20	22.0	2.26	7.6	13.3	2.62	17.7	2.74	22.0	2.85	23.3	2.71	24.5	2.57	35.0	3.21	39.3	3.32
	G1UA048S21	34.0	3.00	20.2	2.14	7.2	11.3	2.40	15.7	2.58	20.2	2.77	24.7	2.95	29.5	3.15	34.0	3.32	40.5	3.50
	G1FA048S21	34.0	3.00	20.2	2.14	7.2	11.3	2.40	15.7	2.58	20.2	2.77	24.7	2.95	29.5	3.15	34.0	3.32	40.5	3.50
EABA-(T,W)036S	G2FD042(S,H)21	34.0	3.00	20.2	2.14	7.2	11.3	2.40	15.7	2.58	20.2	2.77	24.7	2.94	29.5	3.15	34.0	3.32	40.5	3.50
	G1NA036S17L	35.0	3.20	22.0	2.26	7.6	13.3	2.62	17.7	2.74	22.0	2.85	23.3	2.71	24.5	2.57	35.0	3.21	39.3	3.32
	G1NA048S21D	35.0	3.20	22.0	2.26	7.6	13.3	2.62	17.7	2.74	22.0	2.85	23.3	2.71	24.5	2.57	35.0	3.21	39.3	3.32
	G1UA048S21	34.0	3.00	20.2	2.14	7.2	11.3	2.40	15.7	2.58	20.2	2.77	24.7	2.95	29.5	3.15	34.0	3.32	40.5	3.50
	G1FA048S21	34.0	3.00	20.2	2.14	7.2	11.3	2.40	15.7	2.58	20.2	2.77	24.7	2.95	29.5	3.15	34.0	3.32	40.5	3.50
EABA-F042S	G2FD042(S,H)21	39.0	3.22	23.4	2.08	7.4	13.0	3.13	18.2	3.21	23.4	3.30	27.7	3.35	32.1	3.40	39.0	3.55	44.2	3.63
	G2FD046(S,H)17	39.0	3.24	23.4	2.08	7.4	13.0	3.14	18.2	3.22	23.4	3.30	27.7	3.35	32.1	3.41	39.0	3.53	44.2	3.60
	G2FD048(S,H)21,24	39.5	3.34	23.4	2.10	7.4	12.4	3.04	17.9	3.15	23.4	3.27	28.9	3.38	34.9	3.46	39.5	3.47	46.8	3.66
	G1HD048	39.0	3.24	23.4	2.10	7.4	11.8	2.96	17.6	3.11	23.4	3.27	29.2	3.42	33.1	3.43	39.0	3.52	47.8	3.82
	G1NA048S21D	40.5	3.26	23.4	2.10	7.4	12.0	3.02	17.7	3.14	23.4	3.27	27.0	3.30	30.5	3.33	40.5	3.64	46.2	3.77
	G1NA048S24P	40.5	3.26	23.4	2.10	7.4	12.0	3.02	17.7	3.14	23.4	3.27	27.0	3.30	30.5	3.33	40.5	3.64	46.2	3.77
	G1UA048S21	39.0	3.24	23.4	2.10	7.4	11.8	2.97	17.6	3.12	23.4	3.27	29.2	3.41	35.6	3.53	39.0	3.52	46.1	3.75
	G1FA048S21	39.0	3.24	23.4	2.10	7.4	11.8	2.97	17.6	3.12	23.4	3.27	29.2	3.41	35.6	3.53	39.0	3.52	46.1	3.75
EBBA-F048S	G2FD048(S,H)21,24	47.0	3.02	31.2	2.32	7.5	21.0	3.56	26.1	3.75	31.2	3.94	36.3	4.13	40.1	4.32	47.0	4.56	54.1	4.59
	G2FD060(S,H)24	47.0	3.00	31.2	2.30	7.5	21.0	3.60	26.1	3.79	31.2	3.98	36.3	4.17	42.0	4.39	47.0	4.59	54.1	4.61
	G1HD048	47.0	3.00	31.2	2.30	7.5	20.9	3.60	26.1	3.79	31.2	3.98	36.3	4.17	42.0	4.41	47.0	4.59	53.9	4.63
	G1HD060	47.0	3.00	31.2	2.30	7.5	20.7	3.56	25.9	3.77	31.2	3.98	35.6	4.21	40.0	4.45	47.0	4.59	52.3	4.80
	G1NA048S21D	47.0	2.96	31.2	2.30	7.5	20.7	3.52	25.9	3.75	31.2	3.98	35.2	4.13	39.2	4.29	47.0	4.65	52.3	4.88
	G1NA048S24P	47.0	2.96	31.2	2.30	7.5	20.7	3.52	25.9	3.75	31.2	3.98	35.2	4.13	39.2	4.29	47.0	4.65	52.3	4.88
	G1UA048S21	47.0	3.00	31.2	2.30	7.5	20.9	3.60	26.1	3.79	31.2	3.98	36.3	4.16	42.0	4.39	47.0	4.59	54.0	4.61
	G1UA060S21,24	47.0	3.00	31.2	2.30	7.5	21.0	3.60	26.1	3.79	31.2	3.98	36.3	4.17	42.0	4.39	47.0	4.59	54.1	4.61
	G1FA048S21	47.0	3.00	31.2	2.30	7.5	20.9	3.60	26.1	3.79	31.2	3.98	36.3	4.16	42.0	4.39	47.0	4.59	54.0	4.61
	G1FA060S21,24	47.0	3.00	31.2	2.30	7.5	21.0	3.60	26.1	3.79	31.2	3.98	36.3	4.17	42.0	4.39	47.0	4.59	54.1	4.61

For Notes see Page 7.

HEATING PERFORMANCE - With Furnace Coils (Continued)

UNIT MODEL*	COIL ¹ MODEL	ARI HEATING ²					OUTDOOR TEMP ³													
		47°F		17°F		HSP F	-3°F		7°F		17°F		27°F		37°F		47°F		57°F	
		MBH	COP	MBH	COP	STD	MBH	KW	MBH	KW	MBH	KW	MBH	KW	MBH	KW	MBH	KW	MBH	KW
EBBA-(T,W)048S	G2FD048(S,H)21,24	47.0	3.02	31.2	2.32	7.5	21.0	3.56	26.1	3.75	31.2	3.94	36.3	4.13	40.1	4.32	47.0	4.56	54.1	4.59
	G1NA048S21D	47.0	2.96	31.2	2.30	7.5	20.7	3.52	25.9	3.75	31.2	3.98	35.2	4.13	39.2	4.29	47.0	4.65	52.3	4.88
	G1UA048S21	47.0	3.00	31.2	2.30	7.5	20.9	3.60	26.1	3.79	31.2	3.98	36.3	4.16	42.0	4.39	47.0	4.59	54.0	4.61
	G1FA048S21	47.0	3.00	31.2	2.30	7.5	20.9	3.60	26.1	3.79	31.2	3.98	36.3	4.16	42.0	4.39	47.0	4.59	54.0	4.61
EABA-F060S	G2FD060(S,H)24	56.5	3.10	37.0	2.30	7.5	24.1	4.30	30.6	4.51	37.0	4.71	43.4	4.92	48.2	5.09	56.5	5.34	65.9	5.59
	G1HD060	57.0	3.10	37.0	2.30	7.5	24.0	4.30	30.5	4.51	37.0	4.71	43.5	4.92	48.3	5.10	57.0	5.37	66.1	5.55
	G1NA060S24T	58.0	3.16	37.0	2.38	7.5	23.0	4.01	30.0	4.28	37.0	4.56	40.9	4.69	44.8	4.82	58.0	5.38	65.0	5.65
	G1UA060S21,24	56.5	3.10	37.0	2.30	7.5	24.1	4.30	30.6	4.51	37.0	4.71	43.4	4.92	48.2	5.09	56.5	5.34	65.9	5.59
EABA-(T,W)060S	G1FA060S21,24	56.5	3.10	37.0	2.30	7.5	24.1	4.30	30.6	4.51	37.0	4.71	43.4	4.92	48.2	5.09	56.5	5.34	65.9	5.59
	G2FD060(S,H)24	58.0	3.20	38.5	2.40	7.7	25.5	4.29	32.0	4.50	3.9	4.70	42.1	4.91	45.7	5.11	58.0	5.31	64.5	5.51
	G1UA060S24	58.0	3.20	38.5	2.40	7.7	25.5	4.29	32.0	4.50	3.9	4.70	42.1	4.91	45.7	5.11	58.0	5.31	64.5	5.51
	G1FA060S24	58.0	3.20	38.5	2.40	7.7	25.5	4.29	32.0	4.50	3.9	4.70	42.1	4.91	45.7	5.11	58.0	5.31	64.5	5.51

1. Rated CFM same as for cooling.
2. Heating MBH based on ARI standards of 70° DB entering indoor air, 72% RH outdoor air with 25 feet of interconnecting piping and no supplemental electric heat operation.
3. Integrated heating capacities include the effect of defrost cycles in the temperature range where they occur.
 COP equals MBH output divided by (total KW input x 3.412).
 HSPF (Heating Seasonal Performance Factor) is the total heating output during a normal annual usage period for heating divided by the total electric power input during the same period.
 — = Not Applicable.

ACCESSORIES

Refer to Price Manual for specific model numbers.

Start Assist Kit (2SA067*)

Blower Time Delay - Available to increase efficiency when installed. Installs on indoor section and maintains blower for approximately one minute after cooling thermostat has been satisfied.

Hard Start Kits - Provides required starting torque for use with Thermal Expansion Valve Kit.

Low Temperature Cutout (2LT06700224) - Prevents heat pump operation below -10°F ambient temperature.

Compressor Blanket - Designed to further reduce the normal operating sound.

Add-on Fossil Fuel Control - Interface controls for use with gas, oil furnaces and the heat pump system are available.

Thermal Expansion Valve Kit - 1TV0700 Series TXV kit used to improve system performance.

Outdoor Thermostat (2TD06700124) - Provides additional staging of supplemental electric heat.

Room Thermostats - A wide selection of matching thermostats is available to provide features required for any installation.

2H/1C, manual change-over electronic non-programmable thermostat.

3H/2C, non-programmable digital thermostat.

3H/2C, auto/manual changeover, electronic programmable, 7-day, hardwire thermostat.

* For the most current accessory information, refer to the price book or consult factory.

SOUND RATINGS*

UNIT MODEL	SOUND RATINGS DECIBELS
018	80
024	80
030	80
036	82
042	82
048	77
060	82

*Rated in accordance with ARI Standard 270.

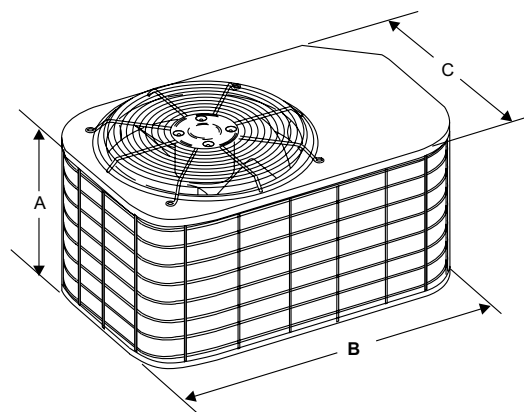

All dimensions are in inches. They are subject to change without notice. Certified dimensions will be provided upon request.

DIMENSIONS - 1 PHASE

UNIT MODEL	DIMENSIONS (INCHES)			REFRIGERANT CONNECTION LINE SIZE	
	A ¹	B	C	Liquid	Vapor
018	19	35	23	3/8"	3/4"
024	25	35	23		
030	25	35	23		
036	25	35	23		
042	27	37	27		
048	33	37	27		
060	39	37	27	7/8"	

1. Including fan guard.

DIMENSIONS - 3 PHASE

UNIT MODEL	DIMENSIONS (INCHES)			REFRIGERANT CONNECTION LINE SIZE	
	A ¹	B	C	Liquid	Vapor
036	25	35	23	3/8"	3/4"
048	33	37	27		7/8"
060	26	43	32		7/8"
090	32	43	32	1/2"	1-1/8"

1. Including fan guard.

TYPICAL INSTALLATION

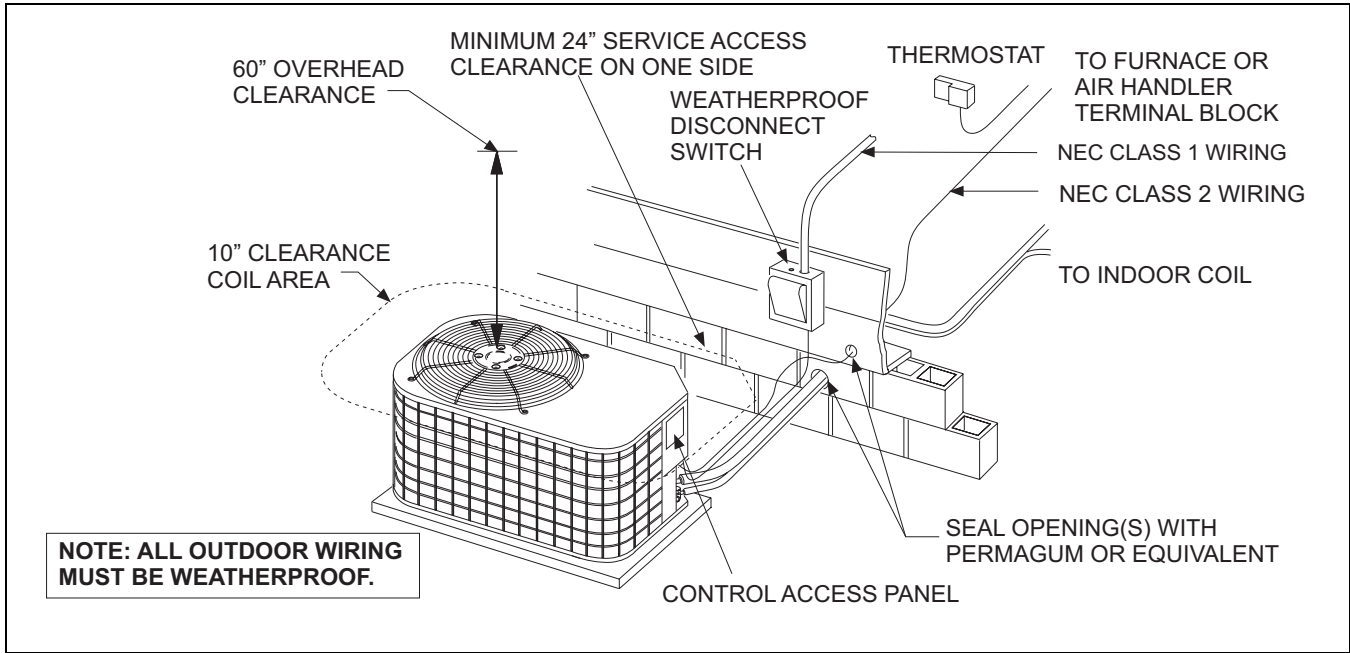

TYPICAL FIELD WIRING - 1 PH

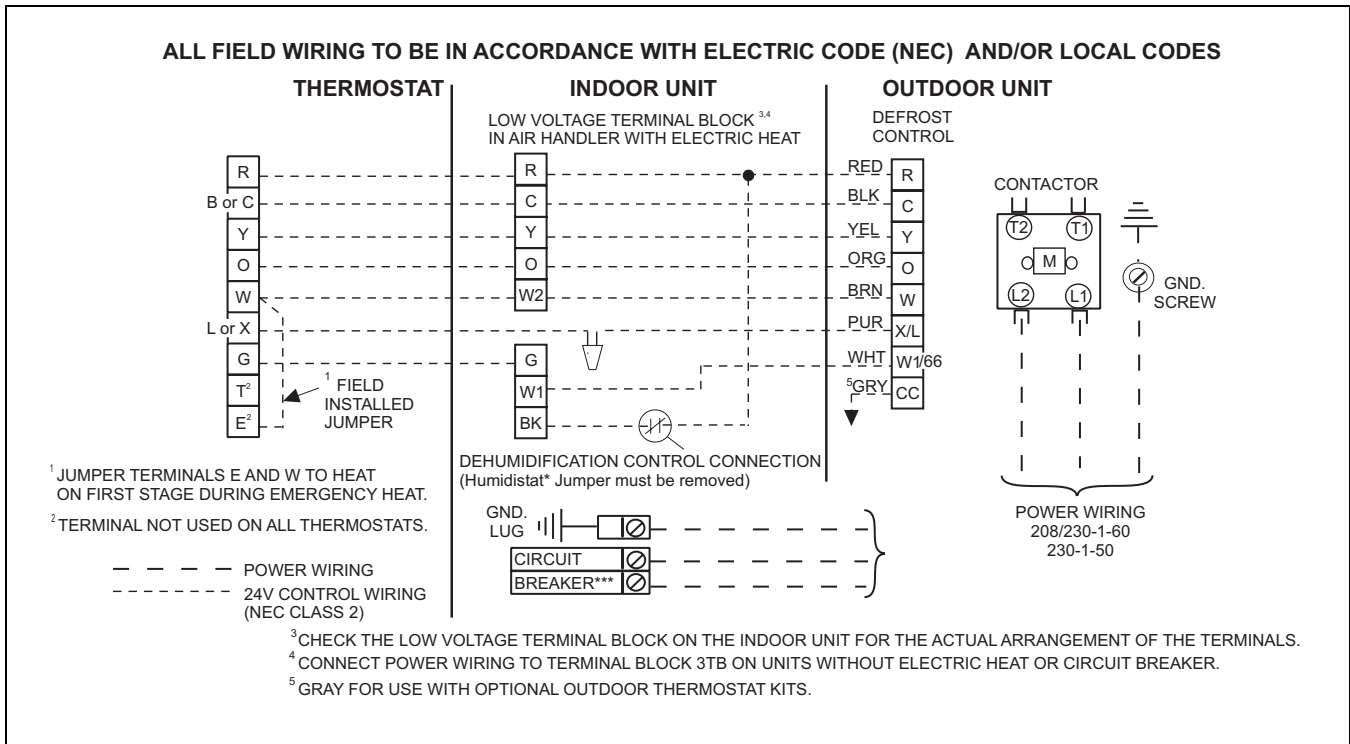

TYPICAL FIELD WIRING - 3 PH (036 - 060)

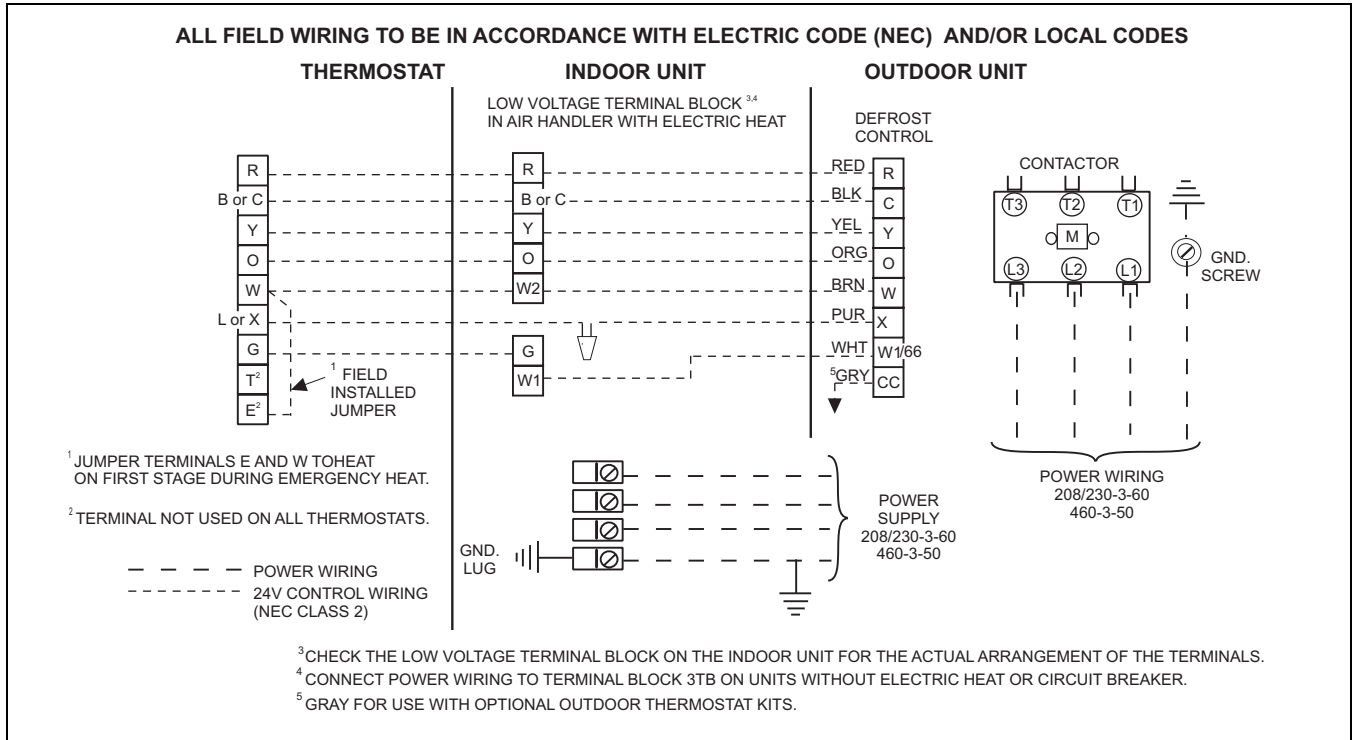

TYPICAL FIELD WIRING - 3 PH (090)

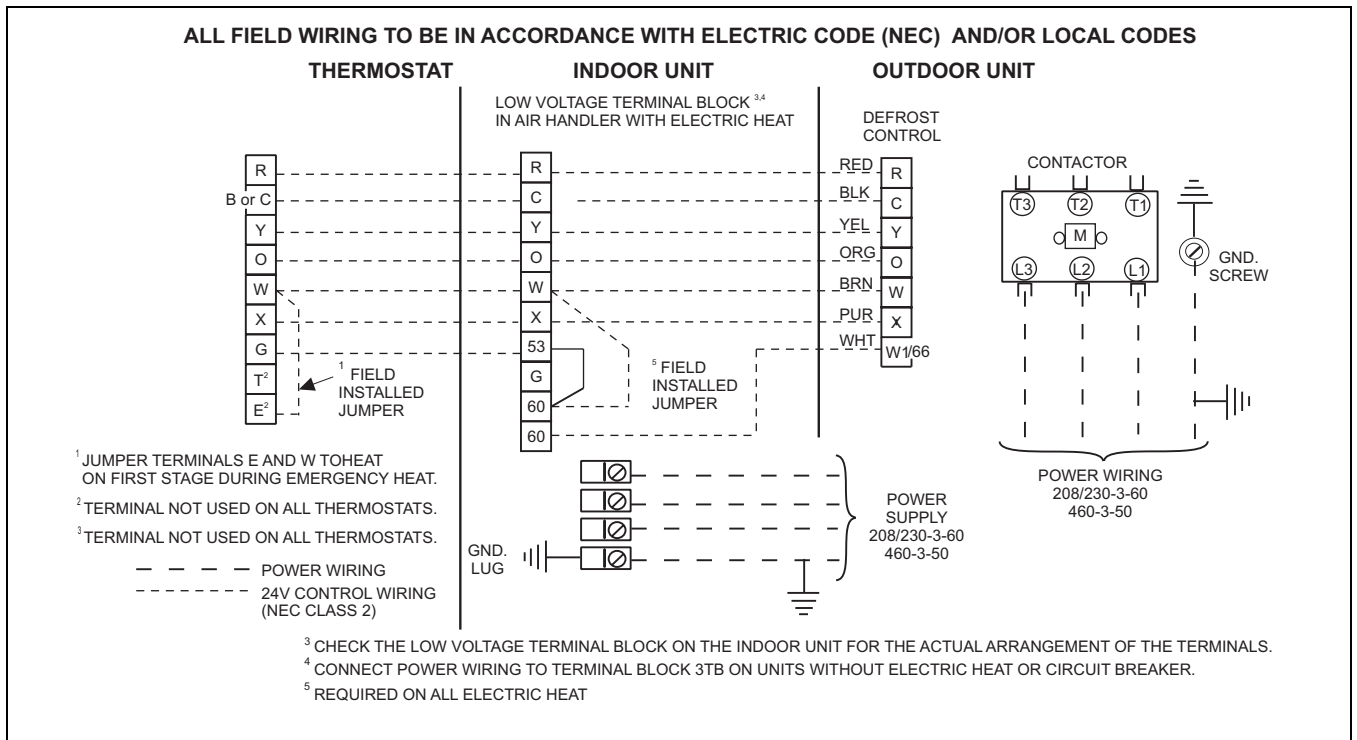

COOLING PERFORMANCE DATA										
AIR CONDITIONER MODEL NO.		EBBA-F018S								
INDOOR COIL MODEL NO.		F2RP/F2FP018								
CONDENSER ENTERING AIR TEMPERATURE	ID CFM	500			650			800		
	ID DB (°F)	85	80	70	85	80	70	85	80	70
	ID WB (°F)	72	67	57	72	67	57	72	67	57
75	T.C.	20.8	18.3	15.1	22.4	19.4	16.0	23.1	20.0	16.6
	S.C.	11.7	11.0	9.8	13.8	12.7	11.5	15.5	14.2	12.8
	KW	1.71	1.91	1.83	1.73	1.94	1.86	1.76	1.98	1.88
85	T.C.	19.4	17.2	14.5	20.5	18.2	15.5	21.1	18.7	16.0
	S.C.	11.4	10.8	10.0	13.4	12.5	11.7	15.0	14.0	13.0
	KW	1.78	1.90	1.92	1.80	1.93	1.95	1.83	1.96	1.97
95	T.C.	17.9	16.1	13.8	18.7	17.0	15.0	19.0	17.5	15.5
	S.C.	11.2	10.5	10.2	13.0	12.3	11.9	14.5	13.8	13.3
	KW	1.85	1.89	2.02	1.87	1.92	2.04	1.89	1.94	2.06
105	T.C.	15.5	14.9	12.5	16.3	15.7	13.3	16.6	16.3	13.8
	S.C.	10.5	10.0	9.3	12.3	11.9	11.0	13.8	13.4	12.4
	KW	2.08	1.99	2.02	2.11	2.02	2.04	2.13	2.04	2.06
115	T.C.	13.0	13.8	11.2	13.9	14.5	11.7	14.3	15.0	12.0
	S.C.	9.8	9.5	8.4	11.7	11.6	10.1	13.1	13.1	11.5
	KW	2.32	2.09	2.03	2.35	2.12	2.05	2.36	2.13	2.07
125	T.C.	10.5	12.6	9.8	11.6	13.3	10.0	11.9	13.8	10.3
	S.C.	9.2	9.0	7.5	11.0	11.2	9.3	12.4	12.7	10.5
	KW	2.56	2.19	2.04	2.59	2.22	2.06	2.60	2.23	2.07

NOTE: ALL CAPACITIES INCLUDE INDOOR FAN HEAT AT 1250 BTUH/1000 CFM.

Multipliers for determining the performance with other indoor sections.

NOTE: For dry bulb temperatures different than those listed (between 73-87 F), sensible capacity increases by 1060 BTUH per 1000 CFM per degree above the listed temperature and decreases by 1060 BTUH per 1000 CFM per degree below the listed temperature.

Air Handler	Coil	T.C.	S.C.	KW
N1AHB0806	G2FD024(S,H)17	1.05	1.04	1.04
F2RP/F2FP024		1.05	1.01	1.04
	G1FA024S14,17	1.04	1.03	1.04
	G1FA030S14	1.05	1.05	1.04
	G1HD024	1.06	1.05	1.05
	G1NA030S17H	1.06	1.10	1.02
	G1NA030S21B	1.06	1.10	1.02
	G1UA024S14,17	1.04	1.03	1.04
	G1UA030S14	1.05	1.05	1.04
	G2FD024(S,H)14,17	1.05	1.04	1.04

COOLING PERFORMANCE DATA													
AIR CONDITIONER MODEL NO.		EBBA-F024S											
INDOOR COIL MODEL NO.		F2RP/F2FP030											
CONDENSER ENTERING AIR TEMPERATURE	ID CFM	650				850				1050			
	ID DB (°F)	85	80	75	70	85	80	75	70	85	80	75	70
	ID WB (°F)	72	67	62	57	72	67	62	57	72	67	62	57
75	T.C.	26.6	24.3	22.4	20.0	27.0	24.7	22.7	20.3	27.1	24.8	22.8	20.9
	S.C.	15.7	15.7	15.0	15.8	16.4	16.4	15.8	16.6	16.8	16.8	16.2	17.4
	KW	2.20	2.12	2.06	1.97	2.21	2.13	2.07	1.99	2.21	2.14	2.08	2.01
85	T.C.	25.7	23.5	21.5	19.4	26.1	23.8	21.9	19.8	26.2	23.9	22.0	20.0
	S.C.	15.8	15.8	15.1	16.1	16.7	16.7	16.0	17.0	17.1	17.1	16.5	17.4
	KW	2.35	2.25	2.18	2.11	2.37	2.27	2.19	2.12	2.37	2.27	2.20	2.12
95	T.C.	23.9	21.7	20.1	17.9	24.2	22.0	20.4	18.2	24.3	22.1	20.5	18.6
	S.C.	15.5	15.4	15.0	15.5	16.5	16.5	15.9	16.6	17.0	17.0	16.4	17.1
	KW	2.50	2.40	2.30	2.21	2.51	2.41	2.33	2.22	2.52	2.42	2.34	2.25
105	T.C.	21.7	19.7	18.2	16.4	21.9	20.1	18.5	16.8	22.1	20.2	18.6	17.0
	S.C.	15.0	15.0	14.3	15.1	16.1	16.2	15.2	15.5	16.7	16.6	15.6	15.7
	KW	2.64	2.51	2.42	2.32	2.65	2.53	2.44	2.35	2.66	2.53	2.45	2.37
115	T.C.	19.5	17.8	16.3	14.8	19.8	18.1	16.7	15.2	19.9	18.1	17.0	15.4
	S.C.	14.4	14.3	13.6	13.7	15.5	15.4	14.5	14.1	15.9	15.8	14.7	14.2
	KW	2.74	2.61	2.51	2.41	2.76	2.62	2.54	2.45	2.77	2.64	2.56	2.46
125	T.C.	17.3	15.9	14.5	13.2	17.7	16.1	15.0	13.6	17.7	16.0	15.3	13.8
	S.C.	13.8	13.6	12.9	12.2	14.9	14.6	13.7	12.7	15.1	15.0	13.7	12.7
	KW	2.84	2.72	2.61	2.50	2.87	2.72	2.65	2.55	2.88	2.74	2.68	2.55

NOTE: ALL CAPACITIES INCLUDE INDOOR FAN HEAT AT 1250 BTUH/1000 CFM.

Multipliers for determining the performance with other indoor sections.

NOTE: For dry bulb temperatures different than those listed (between 73-87 F), sensible capacity increases by 1060 BTUH per 1000 CFM per degree above the listed temperature and decreases by 1060 BTUH per 1000 CFM per degree below the listed temperature.

Air Handler	Coil	T.C.	S.C.	KW
N1AHB0806	G2FD030(S,H)17	1.00	0.96	1.01
F2RP/F2FP024		0.97	0.98	0.98
	G1FA030S14	0.98	0.98	1.00
	G1FA036S17,21	1.00	0.96	1.01
	G1HD024	0.98	0.98	0.99
	G1NA030S17H	1.02	0.96	1.01
	G1NA030S21B	1.02	0.96	1.01
	G1UA030S14	0.98	0.98	1.00
	G1UA036S17,21	1.00	0.96	1.01
	G2FD024(S,H)14,17	0.97	0.94	0.98
	G2FD030(S,H)17	1.00	0.96	1.01
	G2FD035(S,H)14	1.00	0.96	1.01

COOLING PERFORMANCE DATA										
AIR CONDITIONER MODEL NO.		EABA-F030S								
INDOOR COIL MODEL NO.		F2RP/F2FP036								
CONDENSER ENTERING AIR TEMPERATURE	ID CFM	850			1050			1250		
	ID DB (°F)	85	80	70	85	80	70	85	80	70
	ID WB (°F)	72	67	57	72	67	57	72	67	57
75	T.C.	27.1	27.3	26.5	28.3	28.3	28.6	28.8	29.1	29.7
	S.C.	19.7	19.9	19.1	20.9	20.9	21.2	21.4	21.7	22.3
	KW	2.77	2.75	2.71	2.79	2.74	2.72	2.79	2.75	2.72
85	T.C.	27.3	26.9	26.9	29.1	28.4	27.9	30.0	29.8	29.3
	S.C.	19.9	19.5	19.5	21.7	21.0	20.5	22.6	22.4	21.9
	KW	2.95	2.90	2.86	2.98	2.91	2.87	2.99	2.93	2.88
95	T.C.	27.6	26.5	27.2	29.8	28.4	27.2	31.2	30.4	28.9
	S.C.	20.2	19.1	19.8	22.4	21.0	19.8	23.8	23.0	21.5
	KW	3.13	3.06	3.01	3.16	3.09	3.03	3.18	3.12	3.05
105	T.C.	26.6	25.6	25.4	29.0	27.7	26.5	30.6	29.6	28.2
	S.C.	19.2	18.2	18.0	21.6	20.3	19.1	23.2	22.2	20.8
	KW	3.29	3.22	3.15	3.32	3.25	3.18	3.34	3.28	3.20
115	T.C.	25.5	24.7	23.5	28.1	27.0	25.8	30.0	28.8	27.6
	S.C.	18.1	17.3	16.1	20.7	19.6	18.4	22.6	21.4	20.2
	KW	3.44	3.38	3.29	3.47	3.41	3.33	3.50	3.44	3.35
125	T.C.	24.5	23.9	21.7	27.3	26.4	25.0	29.4	28.0	26.9
	S.C.	17.1	16.5	14.3	19.9	19.0	17.6	22.0	20.6	19.5
	KW	3.60	3.53	3.43	3.63	3.56	3.48	3.66	3.59	3.50

NOTE: ALL CAPACITIES INCLUDE INDOOR FAN HEAT AT 1250 BTUH/1000 CFM.

Multipliers for determining the performance with other indoor sections.

NOTE: For dry bulb temperatures different than those listed (between 73-87 F), sensible capacity increases by 1060 BTUH per 1000 CFM per degree above the listed temperature and decreases by 1060 BTUH per 1000 CFM per degree below the listed temperature.

Air Handler	Coil	T.C.	S.C.	KW
N1AHB1206	G2FD030(S,H)17	0.97	0.94	1.00
F2RP/F2FP030		0.98	1.00	1.00
	G1FA036S14	0.98	0.99	1.01
	G1FA036S17,21	0.97	0.97	1.00
	G1HD036	0.98	1.00	1.00
	G1NA030S17H	1.00	0.99	1.00
	G1NA030S21B	1.00	0.99	1.00
	G1UA036S14	0.98	0.99	1.01
	G1UA036S17,21	0.97	0.94	1.00
	G2FD030(S,H)17	0.97	0.94	1.00
	G2FD035(S,H)14	0.97	0.94	1.00
	G2FD036(S,H)17	0.98	0.95	1.00
	G2FD036(S,H)21	0.99	0.95	1.00

COOLING PERFORMANCE DATA													
AIR CONDITIONER MODEL NO.		EABA-F036S, EABA-(T,W)036S)											
INDOOR COIL MODEL NO.		F2RP/F2FP036											
CONDENSER ENTERING AIR TEMPERATURE	ID CFM	1000				1250				1400			
	ID DB (°F)	85	80	75	70	85	80	75	70	85	80	75	70
	ID WB (°F)	72	67	62	57	72	67	62	57	72	67	62	57
75	T.C.	38.1	35.0	32.5	29.4	38.6	35.5	32.9	29.9	38.8	35.7	33.2	30.2
	S.C.	22.9	22.9	22.1	23.6	24.1	24.2	23.4	24.8	24.9	24.9	24.1	25.5
	KW	3.15	3.08	3.02	2.94	3.16	3.10	3.03	2.96	3.17	3.10	3.04	2.97
85	T.C.	37.6	34.6	32.0	28.9	38.1	35.1	32.7	29.4	38.3	35.3	33.0	29.7
	S.C.	23.3	23.4	22.6	23.9	24.8	24.9	24.1	25.3	25.7	25.7	25.0	26.1
	KW	3.39	3.30	3.22	3.12	3.40	3.32	3.24	3.14	3.41	3.33	3.25	3.15
95	T.C.	36.2	33.3	30.9	27.7	36.7	33.7	31.4	28.3	36.8	34.0	31.6	28.6
	S.C.	23.3	23.3	22.6	23.7	24.9	24.9	24.0	25.4	25.8	25.9	24.9	26.2
	KW	3.71	3.60	3.51	3.38	3.72	3.62	3.53	3.40	3.74	3.64	3.55	3.42
105	T.C.	34.4	31.5	29.2	26.3	34.7	32.0	29.6	26.8	35.0	32.2	29.9	27.3
	S.C.	22.9	22.9	22.1	23.3	24.5	24.5	23.5	24.7	25.6	25.5	24.6	25.5
	KW	4.03	3.90	3.79	3.63	4.06	3.93	3.82	3.67	4.06	3.94	3.82	3.71
115	T.C.	32.2	29.6	27.4	24.7	32.6	30.0	27.8	25.5	32.8	30.2	28.1	25.8
	S.C.	22.2	22.2	21.4	22.4	23.9	23.8	22.9	23.8	24.8	24.8	23.8	24.1
	KW	4.34	4.19	4.05	3.88	4.37	4.22	4.09	3.93	4.38	4.24	4.10	3.96
125	T.C.	30.0	27.7	25.6	23.1	30.5	28.0	26.0	24.2	30.6	28.2	26.3	24.3
	S.C.	21.5	21.5	20.6	21.5	23.3	23.1	22.2	22.9	24.0	24.1	23.1	22.7
	KW	4.65	4.48	4.31	4.13	4.68	4.51	4.36	4.19	4.70	4.54	4.38	4.21

NOTE: ALL CAPACITIES INCLUDE INDOOR FAN HEAT AT 1250 BTUH/1000 CFM.

Multipliers for determining the performance with other indoor sections.

NOTE: For dry bulb temperatures different than those listed (between 73-87 F), sensible capacity increases by 1060 BTUH per 1000 CFM per degree above the listed temperature and decreases by 1060 BTUH per 1000 CFM per degree below the listed temperature.

1 Phase

Air Handler	Coil	T.C.	S.C.	KW
N1AHB1206	G2FD036(S,H)17	0.99	1.00	1.01
F2RP/F2FP042		1.00	1.00	1.00
	G1FA048S21	1.01	0.99	1.01
	G1HD036	0.98	0.99	1.00
	G1HD048	1.04	1.04	1.02
	G1NA036S17L	1.03	1.05	1.03
	G1NA048S21D	1.03	1.05	1.04
	G1UA048S21	1.01	0.99	1.01
	G2FD036(S,H)17	0.99	1.00	1.01
	G2FD036(S,H)21	1.00	0.98	0.99
	G2FD042(S,H)21	1.01	1.02	1.01
	G2FD046(S,H)17	1.02	1.03	1.01

3 Phase

Air Handler	Coil	T.C.	S.C.	KW
N1AHC1646	G2FD042(S,H)21	1.01	1.02	1.01
F2RP/F2FP042		1.00	1.00	1.00
	G1FA048S21	1.01	0.99	1.01
	G1NA036S17L	1.03	1.05	1.03
	G1NA048S21D	1.03	1.05	1.04
	G1UA048S21	1.01	0.99	1.01
	G2FD042(S,H)21	1.01	1.02	1.01

COOLING PERFORMANCE DATA										
AIR CONDITIONER MODEL NO.		EABA-F042S								
INDOOR COIL MODEL NO.		F2RP/F2FP042								
CONDENSER ENTERING AIR TEMPERATURE	ID CFM	1200			1400			1600		
	ID DB (°F)	85	80	70	85	80	70	85	80	70
	ID WB (°F)	72	67	57	72	67	57	72	67	57
75	T.C.	44.8	42.1	38.8	45.8	43.0	40.4	46.2	43.5	40.9
	S.C.	27.9	28.4	27.4	29.9	29.7	29.5	30.8	30.8	30.9
	KW	3.74	3.69	3.63	3.76	3.71	3.66	3.78	3.73	3.67
85	T.C.	42.9	39.6	35.7	43.9	41.0	37.1	44.4	41.3	37.9
	S.C.	27.7	27.4	26.0	29.7	29.3	28.1	30.7	30.7	29.8
	KW	3.96	4.02	3.79	3.99	4.05	3.83	4.01	4.07	3.85
95	T.C.	41.1	37.1	32.7	42.0	39.0	33.9	42.5	39.1	34.9
	S.C.	27.5	26.4	24.7	29.5	28.8	26.8	30.7	30.6	28.6
	KW	4.18	4.35	3.95	4.22	4.38	4.00	4.24	4.41	4.03
105	T.C.	37.6	33.7	29.9	38.6	35.0	30.9	39.3	35.4	31.6
	S.C.	26.3	24.9	23.4	28.4	27.2	25.4	30.1	29.0	27.2
	KW	4.38	4.39	4.12	4.42	4.42	4.16	4.45	4.46	4.19
115	T.C.	34.2	30.2	27.1	35.2	31.0	27.8	36.0	31.8	28.3
	S.C.	25.0	23.4	22.1	27.3	25.7	24.1	29.4	27.5	25.7
	KW	4.58	4.42	4.28	4.62	4.47	4.32	4.66	4.50	4.35
125	T.C.	30.8	26.8	24.3	31.7	27.0	24.7	32.8	28.1	24.9
	S.C.	23.8	21.9	20.9	26.2	24.1	22.8	28.7	25.9	24.2
	KW	4.77	4.46	4.45	4.82	4.51	4.48	4.86	4.55	4.50

NOTE: ALL CAPACITIES INCLUDE INDOOR FAN HEAT AT 1250 BTUH/1000 CFM.

Multipliers for determining the performance with other indoor sections.

NOTE: For dry bulb temperatures different than those listed (between 73-87 F), sensible capacity increases by 1060 BTUH per 1000 CFM per degree above the listed temperature and decreases by 1060 BTUH per 1000 CFM per degree below the listed temperature.

Air Handler	Coil	T.C.	S.C.	KW
N1AHC1606	G2FD048(S,H)21	1.03	1.04	1.00
F2FP048		1.01	1.01	0.99
	G1FA048S21	1.01	1.00	0.98
	G1HD048	1.01	1.16	0.99
	G1NA048S21D	1.04	1.01	0.97
	G1UA048S21	1.01	1.00	0.98
	G2FD042(S,H)21	1.00	1.02	0.98
	G2FD046(S,H)17	1.01	1.03	0.99
	G2FD048(S,H)21,24	1.03	1.04	1.00
	G2FD060(S,H)24	1.03	1.04	0.98

COOLING PERFORMANCE DATA													
AIR CONDITIONER MODEL NO.		EBBA-F048S, EBBA-(T,W)048S											
INDOOR COIL MODEL NO.		F2FP048											
CONDENSER ENTERING AIR TEMPERATURE	ID CFM	1300				1450				1550			
	ID DB (°F)	85	80	75	70	85	80	75	70	85	80	75	70
	ID WB (°F)	72	67	62	57	72	67	62	57	72	67	62	57
75	T.C.	52.3	48.3	45.0	40.6	53.0	49.0	45.7	41.3	53.4	49.4	46.1	41.9
	S.C.	32.5	32.8	31.7	33.5	34.0	34.3	33.2	35.1	35.0	35.2	34.1	36.3
	KW	4.14	4.07	4.02	3.95	4.16	4.08	4.04	3.97	4.17	4.09	4.05	3.97
85	T.C.	50.9	47.0	43.7	39.4	51.5	47.6	44.4	40.3	51.9	48.0	44.7	40.6
	S.C.	32.4	32.6	31.6	33.3	34.0	34.2	33.2	35.1	35.2	35.4	34.2	36.2
	KW	4.44	4.36	4.30	4.22	4.46	4.38	4.32	4.24	4.47	4.38	4.33	4.25
95	T.C.	48.8	45.0	41.8	37.9	49.2	45.5	42.4	38.4	49.6	45.8	42.7	38.7
	S.C.	32.0	32.2	31.2	32.9	33.6	33.8	32.9	34.5	34.9	35.1	33.8	35.6
	KW	4.87	4.79	4.73	4.64	4.90	4.81	4.74	4.66	4.91	4.81	4.76	4.67
105	T.C.	46.1	42.5	39.5	35.8	46.6	43.0	40.1	36.3	46.4	43.3	40.4	36.7
	S.C.	31.0	31.1	30.1	32.0	32.9	32.9	31.9	33.7	33.8	34.3	32.9	35.1
	KW	5.37	5.28	5.22	5.12	5.38	5.30	5.22	5.14	5.34	5.30	5.24	5.14
115	T.C.	43.2	39.9	37.0	33.5	43.6	40.3	37.6	34.2	43.8	40.6	37.9	35.0
	S.C.	29.9	30.2	29.2	30.7	31.8	32.1	30.8	32.8	32.9	33.1	31.8	34.5
	KW	5.90	5.80	5.74	5.66	5.90	5.80	5.76	5.66	5.92	5.83	5.78	5.68
125	T.C.	40.3	37.3	34.6	31.2	40.6	37.6	35.0	32.1	41.2	37.9	35.3	33.3
	S.C.	28.8	29.3	28.2	29.4	30.7	31.3	29.7	31.9	32.0	31.9	30.8	33.9
	KW	6.43	6.32	6.27	6.20	6.42	6.30	6.31	6.18	6.50	6.36	6.31	6.22

NOTE: ALL CAPACITIES INCLUDE INDOOR FAN HEAT AT 1250 BTUH/1000 CFM.

Multipliers for determining the performance with other indoor sections.

NOTE: For dry bulb temperatures different than those listed (between 73-87 F), sensible capacity increases by 1060 BTUH per 1000 CFM per degree above the listed temperature and decreases by 1060 BTUH per 1000 CFM per degree below the listed temperature.

1 Phase

Air Handler	Coil	T.C.	S.C.	KW
N1AHC1606	G2FD048(S,H)21	1.00	1.00	0.97
N1AHD2006	G2FD048(S,H)24	1.00	1.00	0.97
N1AHD2006	G2FD060(S,H)24	1.03	1.03	1.01
F2FP060		1.02	1.01	1.02
	G1FA048S21	1.00	0.97	0.98
	G1FA060S21,24	1.01	1.01	0.97
	G1HD048	0.98	0.98	0.96
	G1HD060	1.00	1.00	0.96
	G1NA048S21D	0.99	0.93	0.95
	G1UA048S21	1.00	0.97	0.98
	G1UA060S21,24	1.01	1.01	0.97
	G2FD048(S,H)21,24	1.00	1.00	0.97
	G2FD060(S,H)24	1.01	1.01	0.96

3 Phase

Air Handler	Coil	T.C.	S.C.	KW
N1AHC1646	G2FD048(S,H)21	1.00	1.00	0.97
N1AHD2046	G2FD048(S,H)24	1.00	1.00	0.97
F2FP060		1.02	1.01	1.02
	G1FA048S21	1.00	0.97	0.98
	G1NA048S21D	0.99	0.93	0.95
	G1UA048S21	1.00	0.97	0.98
	G2FD048(S,H)21,24	1.00	1.00	0.97

COOLING PERFORMANCE DATA													
AIR CONDITIONER MODEL NO.		EABA-F060S											
INDOOR COIL MODEL NO.		F2FP060											
CONDENSER ENTERING AIR TEMPERATURE	ID CFM	1550				1750				1950			
	ID DB (°F)	85	80	75	70	85	80	75	70	85	80	75	70
	ID WB (°F)	72	67	62	57	72	67	62	57	72	67	62	57
75	T.C.	62.6	57.9	53.9	48.8	63.6	58.8	54.9	49.7	64.1	59.4	55.4	50.3
	S.C.	39.7	40.1	38.8	41.2	42.3	42.6	41.3	43.6	44.0	44.4	43.0	45.4
	KW	5.15	5.08	5.03	4.94	5.16	5.09	5.05	4.96	5.17	5.10	5.06	4.98
85	T.C.	60.0	55.5	51.8	46.7	61.0	56.4	52.7	47.7	61.4	56.8	53.2	48.3
	S.C.	38.8	39.1	38.0	40.1	41.3	41.6	40.3	42.5	42.8	43.2	42.0	44.4
	KW	5.61	5.54	5.48	5.39	5.63	5.55	5.51	5.41	5.64	5.57	5.53	5.42
95	T.C.	57.7	53.3	49.6	44.8	58.4	54.0	50.3	45.7	58.8	54.4	51.1	46.3
	S.C.	38.0	38.3	37.1	39.1	40.2	40.5	39.3	41.4	41.9	42.2	41.1	43.3
	KW	6.33	6.25	6.20	6.09	6.35	6.28	6.22	6.11	6.36	6.29	6.23	6.12
105	T.C.	55.1	50.9	47.4	42.8	55.6	51.5	48.2	43.6	56.0	51.8	48.7	44.1
	S.C.	37.1	37.4	36.1	38.0	39.3	39.5	38.5	40.5	40.9	41.1	40.1	42.2
	KW	7.16	7.08	7.02	6.90	7.19	7.11	7.04	6.93	7.20	7.13	7.06	6.94
115	T.C.	52.0	48.1	44.8	40.4	52.5	48.6	45.6	41.2	52.9	49.2	46.0	41.8
	S.C.	35.6	36.0	34.8	36.8	38.0	38.3	37.3	39.3	39.7	40.4	38.8	40.9
	KW	8.13	8.02	7.95	7.82	8.14	8.04	7.97	7.84	8.15	8.05	7.99	7.86
125	T.C.	48.9	45.3	42.1	38.0	49.4	45.7	42.9	38.8	49.8	46.6	43.2	39.5
	S.C.	34.2	34.7	33.6	35.5	36.7	37.1	36.2	38.1	38.5	39.7	37.4	39.6
	KW	9.10	8.96	8.89	8.74	9.09	8.97	8.91	8.76	9.10	8.97	8.93	8.79

NOTE: ALL CAPACITIES INCLUDE INDOOR FAN HEAT AT 1250 BTUH/1000 CFM.

Multipliers for determining the performance with other indoor sections.

NOTE: For dry bulb temperatures different than those listed (between 73-87 F), sensible capacity increases by 1060 BTUH per 1000 CFM per degree above the listed temperature and decreases by 1060 BTUH per 1000 CFM per degree below the listed temperature.

Air Handler	Coil	T.C.	S.C.	KW
N1AHD2006	G2FD060(S,H)24	1.01	0.97	0.97
	G1FA060S21,24	1.01	0.97	0.98
	G1HD060	1.01	0.84	0.99
	G1NA060S24T	0.99	0.88	0.95
	G1UA060S21,24	1.01	0.97	0.98
	G2FD060(S,H)24	1.01	0.97	0.98

COOLING PERFORMANCE DATA										
AIR CONDITIONER MODEL NO.		EABA-(T,W)060S)								
INDOOR COIL MODEL NO.		G2FD060(S,H)24								
CONDENSER ENTERING AIR TEMPERATURE	ID CFM	1600			1800			2000		
	ID DB (°F)	85	80	75	85	80	75	85	80	75
	ID WB (°F)	71	67	63	71	67	63	71	67	63
65	T.C.	63.0	61.1	60.7	62.9	60.9	61.1	62.9	60.6	61.4
	S.C.	39.6	39.7	40.3	41.6	41.5	42.2	43.7	43.3	44.1
	KW	3.71	3.66	3.68	3.71	3.66	3.67	3.71	3.67	3.67
75	T.C.	62.3	59.8	57.9	62.5	60.0	58.5	62.6	60.1	59.0
	S.C.	39.6	39.3	39.1	41.8	41.3	41.1	43.9	43.3	43.1
	KW	4.20	4.14	4.12	4.21	4.15	4.13	4.21	4.16	4.13
85	T.C.	61.7	58.5	55.1	62.0	59.1	55.9	62.3	59.6	56.6
	S.C.	39.6	38.9	38.0	41.9	41.1	40.1	44.2	43.3	42.2
	KW	4.70	4.63	4.57	4.71	4.64	4.58	4.72	4.65	4.60
95	T.C.	61.0	57.2	52.3	61.5	58.2	53.3	62.0	59.1	54.2
	S.C.	39.6	38.5	36.8	42.0	40.9	39.0	44.4	43.3	41.2
	KW	5.19	5.11	5.01	5.21	5.13	5.04	5.22	5.14	5.06
105	T.C.	58.3	53.9	49.1	59.1	54.7	49.9	60.0	55.6	50.7
	S.C.	38.5	37.2	35.4	41.0	39.6	37.6	43.6	41.9	39.8
	KW	5.78	5.67	5.55	5.80	5.69	5.57	5.82	5.71	5.60
115	T.C.	55.5	50.5	45.9	56.8	51.3	46.5	58.0	52.1	47.1
	S.C.	37.4	35.9	34.0	40.1	38.2	36.2	42.7	40.5	38.3
	KW	6.36	6.22	6.08	6.39	6.25	6.11	6.41	6.27	6.13

NOTE: ALL CAPACITIES INCLUDE INDOOR FAN HEAT AT 1250 BTUH/1000 CFM.

Multipliers for determining the performance with other indoor sections.

NOTE: For dry bulb temperatures different than those listed (between 73-87 F), sensible capacity increases by 1060 BTUH per 1000 CFM per degree above the listed temperature and decreases by 1060 BTUH per 1000 CFM per degree below the listed temperature.

Air Handler	Coil	T.C.	S.C.	KW
N1AHD2046	G2FD060(S,H)24	1.00	1.00	1.00
F2FP060	G1FA060S21,24	0.98	0.98	1.02
	G1FA060S21,24	1.00	1.00	1.00
	G1UA060S21,24	1.00	1.00	1.00

COOLING PERFORMANCE DATA										
AIR CONDITIONER MODEL NO.		EABA-(T,W)090S								
INDOOR COIL MODEL NO.		FCEH090								
CONDENSER ENTERING AIR TEMPERATURE	ID CFM	2400			3000			3600		
	ID DB (°F)	85	80	70	85	80	70	85	80	70
	ID WB (°F)	72	67	57	72	67	57	72	67	57
		T.C.	S.C.	K.W	T.C.	S.C.	K.W	T.C.	S.C.	K.W
75	T.C.	103.9	94.3	88.5	107.3	98.0	92.1	110.6	101.8	95.7
	S.C.	86.2	82.8	81.1	95.3	91.5	89.1	104.4	100.3	97.2
	K.W	8.13	8.14	7.84	8.22	8.18	7.94	8.30	8.22	8.03
85	T.C.	99.6	91.2	85.5	103.1	94.6	88.8	106.5	98.0	92.1
	S.C.	84.1	80.9	79.0	93.4	89.5	87.2	102.8	98.1	95.4
	K.W	8.91	8.83	8.61	8.98	8.89	8.69	9.06	8.94	8.78
95	T.C.	95.3	88.2	82.4	98.8	91.2	85.5	102.3	94.2	88.6
	S.C.	82.0	79.0	76.8	91.6	87.4	85.2	101.1	95.8	93.6
	K.W	9.68	9.53	9.38	9.75	9.60	9.45	9.82	9.66	9.53
105	T.C.	91.1	84.2	78.6	94.4	86.9	81.5	97.6	89.5	84.5
	S.C.	79.4	76.8	74.6	89.0	85.0	82.9	98.7	93.3	91.1
	K.W	10.62	10.47	10.33	10.70	10.55	10.40	10.78	10.63	10.46
115	T.C.	86.9	80.2	74.7	89.9	82.5	77.6	92.9	84.8	80.5
	S.C.	76.7	74.6	72.5	86.5	82.7	80.5	96.3	90.8	88.5
	K.W	11.55	11.41	11.29	11.64	11.50	11.34	11.74	11.60	11.40
125	T.C.	82.7	76.2	70.8	85.4	78.2	73.6	88.1	80.1	76.4
	S.C.	74.1	72.4	70.3	84.0	80.4	78.2	93.8	88.3	86.0
	K.W	12.48	12.35	12.24	12.59	12.46	12.29	12.69	12.57	12.33

NOTE: ALL CAPACITIES ARE NET WITH INDOOR FAN HEAT ALREADY DEDUCTED AT 1250 BTUH/1000 CFM.

HEATING PERFORMANCE DATA										
CONDENSING UNIT MODEL NO.		EBBA-F018S								
EVAPORATOR COIL MODEL NO.		F2RP/F2FP018								
AIR TEMP. ENTERING OUTDOOR UNIT	AIR TEMP. ENTERING INDOOR COIL	ID CFM								
		500			650			800		
		MBTUH	KW	C.O.P.	MBTUH	K	C.O.P.	MBTUH	KW	C.O.P.
60	60	21.1	1.70	3.66	21.8	1.70	3.76	22.0	1.57	4.11
	70	20.1	1.73	3.42	21.0	1.74	3.53	21.3	1.62	3.86
	80	19.0	1.76	3.16	20.0	1.79	3.28	20.6	1.68	3.60
47	60	17.8	1.62	3.22	18.0	1.64	3.21	18.1	1.54	3.43
	70	16.5	1.67	2.91	17.0	1.69	2.96	17.3	1.58	3.21
	80	15.2	1.72	2.60	16.0	1.74	2.70	16.4	1.63	2.97
40	60	13.6	1.30	3.05	15.5	1.60	2.84	16.1	1.50	3.15
	70	12.6	1.49	2.49	14.5	1.64	2.59	14.4	1.54	2.73
	80	11.6	1.98	1.73	13.5	1.70	2.34	12.7	1.87	2.00
30	60	13.1	1.54	2.50	13.5	1.55	2.55	13.2	1.42	2.72
	70	12.0	1.58	2.22	12.4	1.60	2.28	12.5	1.49	2.46
	80	10.8	1.62	1.94	11.4	1.66	2.01	11.8	1.57	2.21
17	60	9.7	1.43	1.99	10.2	1.45	2.06	10.4	1.37	2.21
	70	8.6	1.51	1.66	9.1	1.50	1.78	9.3	1.46	1.88
	80	7.5	1.61	1.36	8.0	1.56	1.50	8.3	1.55	1.58
10	60	8.1	1.35	1.77	8.6	1.38	1.82	8.9	1.30	2.01
	70	6.9	1.39	1.46	7.5	1.43	1.53	7.9	1.35	1.71
	80	5.6	1.43	1.16	6.3	1.48	1.25	6.9	1.41	1.43

NOTE: ALL CAPACITIES INCLUDE INDOOR FAN HEAT AT 1250 BTUH/1000 CFM.

Multipliers for determining the performance with other indoor sections.

Air Handler	Coil	MBH	KW	COP
N1AHB0806	G2FD024(S,H)14,17	1.00	0.98	1.02
F2RP/F2FP024		1.00	0.98	1.01
	G2FD024(S,H)14,17	1.00	0.98	1.02
	G1HD024	1.01	0.98	1.03
	G1NA030S17H	1.01	1.01	1.00
	G1NA030S21B	1.01	1.01	1.00
	G1UA024S14,17	0.99	0.99	1.00
	G1FA024S14,17	0.99	0.99	1.00
	G1UA030S14	1.00	0.98	1.02
	G1FA030S14	1.00	0.98	1.02

HEATING PERFORMANCE DATA										
CONDENSING UNIT MODEL NO.		EBBA-F024S								
EVAPORATOR COIL MODEL NO.		F2RP/F2FP030								
AIR TEMP. ENTERING OUTDOOR UNIT	AIR TEMP. ENTERING INDOOR COIL	ID CFM								
		650			850			1050		
		MBTUH	KW	C.O.P.	MBTUH	KW	C.O.P.	MBTUH	KW	C.O.P.
60	60	27.4	2.01	4.00	27.6	1.98	4.09	27.1	1.79	4.44
	70	26.2	2.07	3.72	26.8	2.04	3.85	26.6	1.86	4.20
	80	25.1	2.26	3.26	26.1	2.24	3.41	26.2	2.05	3.74
47	60	22.8	1.91	3.49	22.8	1.95	3.42	23.3	1.81	3.77
	70	21.6	1.97	3.22	22.0	2.02	3.20	22.7	1.88	3.55
	80	20.4	2.12	2.82	21.2	2.18	2.84	22.2	2.05	3.18
40	60	17.6	1.61	3.20	20.0	1.96	2.99	20.8	1.84	3.31
	70	16.7	1.83	2.67	19.2	2.02	2.78	19.0	1.90	2.93
	80	15.8	2.52	1.84	18.4	2.17	2.48	17.3	2.38	2.13
30	60	16.4	1.86	2.59	16.8	1.87	2.64	16.5	1.72	2.82
	70	15.3	1.89	2.37	16.0	1.92	2.44	16.1	1.79	2.63
	80	14.3	1.98	2.11	15.1	2.02	2.19	15.6	1.91	2.40
17	60	12.0	1.70	2.07	12.4	1.76	2.06	12.8	1.64	2.30
	70	11.0	1.71	1.88	11.5	1.79	1.88	12.0	1.66	2.12
	80	10.0	1.72	1.71	10.6	1.82	1.70	11.2	1.68	1.94
10	60	9.7	1.64	1.74	10.1	1.67	1.78	10.5	1.56	1.97
	70	8.5	1.63	1.53	9.2	1.67	1.61	9.3	1.58	1.73
	80	7.4	1.59	1.36	8.2	1.64	1.47	8.2	1.57	1.54

NOTE: ALL CAPACITIES INCLUDE INDOOR FAN HEAT AT 1250 BTUH/1000 CFM.

Multipliers for determining the performance with other indoor sections.

Air Handler	Coil	MBH	KW	COP
N1AHB0806	G2FD030(S,H)17	0.94	1.04	0.91
F2FP024		0.92	1.01	0.91
	G2FD035(S,H)14	0.94	1.04	0.91
	G2FD030(S,H)17	0.94	1.04	0.91
	G2FD024(S,H)14,17	0.93	1.01	0.92
	G1HD024	0.93	1.03	0.91
	G1NA030S17H	0.98	1.04	0.94
	G1NA030S21B	0.98	1.04	0.94
	G1UA030S14	0.93	1.01	0.92
	G1UA036S17,21	0.94	1.04	0.91
	G1FA030S14	0.93	1.01	0.92
	G1FA036S17,21	0.94	1.04	0.91

HEATING PERFORMANCE DATA										
CONDENSING UNIT MODEL NO		EABA-F030S								
EVAPORATOR COIL MODEL NO		F2RP/F2FP036								
AIR TEMP. ENTERING OUTDOOR UNIT	AIR TEMP. ENTERING INDOOR COIL	ID CFM								
		850			1050			1250		
		MBTUH	KW	C.O.P.	MBTUH	KW	C.O.P.	MBTUH	KW	C.O.P.
60	60	35.4	2.72	3.82	35.7	2.71	3.87	35.9	2.69	3.91
	70	33.9	2.82	3.53	35.1	2.83	3.64	35.7	2.84	3.69
	80	32.5	2.90	3.29	34.7	2.93	3.48	35.6	2.95	3.54
47	60	29.6	2.63	3.31	29.9	2.63	3.34	30.1	2.63	3.35
	70	28.0	2.72	3.02	29.0	2.74	3.10	29.5	2.76	3.14
	80	26.5	2.80	2.77	28.2	2.84	2.92	29.0	2.87	2.96
40	60	24.7	2.50	2.90	25.4	2.54	2.94	25.6	2.56	2.93
	70	23.3	2.60	2.63	24.1	2.63	2.69	24.4	2.66	2.69
	80	22.0	2.71	2.38	22.9	2.73	2.46	23.2	2.76	2.47
30	60	21.5	2.38	2.65	22.3	2.41	2.72	22.7	2.44	2.73
	70	19.7	2.43	2.37	20.6	2.47	2.45	21.1	2.51	2.47
	80	17.9	2.51	2.09	18.9	2.56	2.16	19.5	2.61	2.19
17	60	17.5	2.36	2.17	17.7	2.40	2.17	18.0	2.47	2.14
	70	15.8	2.42	1.91	16.3	2.47	1.94	16.7	2.53	1.94
	80	14.1	2.49	1.67	14.8	2.53	1.72	15.4	2.59	1.74
10	60	14.4	2.18	1.94	15.2	2.23	2.00	15.7	2.29	2.01
	70	13.0	2.22	1.72	13.6	2.27	1.77	14.2	2.33	1.79
	80	11.6	2.25	1.51	12.0	2.30	1.53	12.6	2.36	1.57

NOTE: ALL CAPACITIES INCLUDE INDOOR FAN HEAT AT 1250 BTUH/1000 CFM.

Multipliers for determining the performance with other indoor sections.

Air Handler	Coil	MBH	KW	COP
N1AHB1206	G2FD030(S,H)17	1.01	1.01	0.99
F2RP/F2FP030		0.99	0.99	1.00
	G2FD030(S,H)17	1.01	1.01	0.99
	G2FD035(S,H)14	1.01	1.01	0.99
	G2FD036(S,H)17	1.01	1.02	1.00
	G2FD036(S,H)21	1.02	1.02	1.00
	G1HD036	1.02	1.02	1.00
	G1NA030S17H	1.01	1.02	0.99
	G1NA030S21B	1.01	1.02	0.99
	G1UA03614	1.01	1.02	1.00
	G1FA03614	1.01	1.02	1.00
	G1UA036S17,21	1.01	1.01	0.99
	G1FA036S17,21	1.01	1.01	0.99

HEATING PERFORMANCE DATA										
CONDENSING UNIT MODEL NO		EABA-F036S, EABA-(T,W)036S								
EVAPORATOR COIL MODEL NO		F2RP/F2FP036								
AIR TEMP. ENTERING OUTDOOR UNIT	AIR TEMP. ENTERING INDOOR COIL	ID CFM								
		1000			1250			1400		
		MBTUH	KW	C.O.P.	MBTUH	KW	C.O.P.	MBTUH	KW	C.O.P.
60	60	41.6	3.37	3.62	42.0	3.30	3.73	41.3	3.27	3.70
	70	39.1	3.54	3.24	40.2	3.49	3.37	40.2	3.49	3.38
	80	37.4	3.70	2.97	39.1	3.67	3.12	39.7	3.69	3.16
47	60	35.3	3.17	3.26	35.7	3.15	3.32	34.8	3.15	3.24
	70	33.1	3.32	2.93	34.0	3.32	3.00	33.8	3.33	2.98
	80	31.5	3.46	2.67	32.7	3.48	2.76	33.3	3.49	2.80
40	60	30.2	3.02	2.94	31.2	3.03	3.02	31.9	3.05	3.08
	70	28.7	3.14	2.68	29.5	3.16	2.74	30.4	3.18	2.81
	80	27.1	3.28	2.43	27.9	3.30	2.48	28.9	3.32	2.55
30	60	26.1	2.89	2.65	27.4	2.93	2.74	27.5	2.96	2.73
	70	24.4	2.96	2.42	25.8	3.01	2.51	26.1	3.04	2.51
	80	22.4	3.07	2.14	23.8	3.13	2.23	24.3	3.16	2.25
17	60	21.4	2.66	2.36	21.9	2.71	2.37	22.0	2.74	2.36
	70	19.7	2.73	2.12	20.4	2.79	2.15	20.7	2.82	2.15
	80	18.0	2.79	1.89	18.9	2.86	1.94	19.3	2.89	1.96
10	60	18.1	2.50	2.12	18.8	2.56	2.16	19.1	2.60	2.16
	70	16.5	2.55	1.90	17.4	2.62	1.95	17.7	2.66	1.96
	80	14.8	2.58	1.68	15.8	2.65	1.75	16.2	2.69	1.77

NOTE: ALL CAPACITIES INCLUDE INDOOR FAN HEAT AT 1250 BTUH/1000 CFM.

Multipliers for determining the performance with other indoor sections.

1 PHASE

Air Handler	Coil	MBH	KW	COP
N1AHB1206	G2FD036(S,H)17	1.00	0.99	1.01
F2RP/F2FP042		1.00	1.00	1.00
	G2FD036(S,H)17	1.00	0.99	1.01
	G2FD036(S,H)21	0.98	1.01	0.97
	G2FD042(S,H)21	1.00	1.00	1.00
	G2FD046(S,H)17	0.99	0.99	1.00
	G1HD036	1.00	0.99	1.01
	G1HD048	1.01	0.99	1.02
	G1NA036S17L	1.03	0.97	1.07
	G1NA048S21D	1.03	0.97	1.07
	G1UA048S21	1.00	1.00	1.00
	G1FA048S21	1.00	1.00	1.00

3 PHASE

Air Handler	Coil	MBH	KW	COP
N1AHC1646	G2FD042(S,H)21	1.00	1.00	1.00
F2RP/F2FP042		1.00	1.00	1.00
	G2FD042(S,H)21	1.00	1.00	1.00
	G1NA036S17L	1.03	0.97	1.07
	G1NA048S21D	1.03	0.97	1.07
	G1UA048S21	1.00	1.00	1.00
	G1FA048S21	1.00	1.00	1.00

HEATING PERFORMANCE DATA										
CONDENSING UNIT MODEL NO		EABA-F042S								
EVAPORATOR COIL MODEL NO		F2RP/F2FP042								
AIR TEMP. ENTERING OUTDOOR UNIT	AIR TEMP. ENTERING INDOOR COIL	ID CFM								
		1200			1400			1600		
		MBTUH	KW	C.O.P.	MBTUH	KW	C.O.P.	MBTUH	KW	C.O.P.
60	60	48.5	3.39	4.21	47.4	3.30	4.22	46.1	3.25	4.16
	70	46.6	3.68	3.72	45.6	3.57	3.75	44.9	3.53	3.74
	80	46.6	4.11	3.33	45.8	3.99	3.37	45.6	3.92	3.41
47	60	40.8	3.39	3.54	40.5	3.33	3.57	39.7	3.32	3.52
	70	39.3	3.66	3.15	39.0	3.60	3.18	38.6	3.58	3.17
	80	39.0	4.06	2.82	38.8	3.99	2.86	38.7	3.94	2.88
40	60	37.1	3.48	3.13	36.4	3.45	3.11	36.3	3.43	3.11
	70	35.3	3.79	2.73	34.8	3.75	2.73	34.9	3.72	2.75
	80	34.4	4.16	2.43	34.2	4.10	2.45	34.4	4.07	2.48
30	60	31.8	3.13	2.99	31.8	3.11	3.00	31.8	3.12	3.00
	70	30.5	3.45	2.60	30.1	3.40	2.60	30.4	3.40	2.63
	80	29.8	3.75	2.34	29.0	3.67	2.32	29.7	3.67	2.38
17	60	23.7	3.09	2.25	24.0	3.11	2.27	24.3	3.12	2.29
	70	22.7	3.31	2.01	23.1	3.32	2.05	23.3	3.33	2.06
	80	21.6	3.55	1.79	22.2	3.55	1.84	22.4	3.56	1.85
10	60	19.8	2.91	2.00	20.1	2.93	2.01	20.4	2.97	2.02
	70	18.8	3.09	1.79	19.3	3.12	1.82	19.5	3.15	1.82
	80	17.4	3.24	1.58	18.2	3.27	1.63	18.3	3.29	1.64

NOTE: ALL CAPACITIES INCLUDE INDOOR FAN HEAT AT 1250 BTUH/1000 CFM.

Multipliers for determining the performance with other indoor sections.

Air Handler	Coil	MBH	KW	COP
N1AHC1606	G2FD048(S,H)21	1.00	0.99	1.01
F2FP048		1.01	0.98	1.04
	G2FD042(S,H)21	0.99	1.01	0.98
	G2FD046(S,H)17	0.99	1.00	0.98
	G2FD048(S,H)21,24	1.00	0.99	1.01
	G2FD060(S,H)24	1.00	1.02	0.98
	G1HD048	0.99	1.00	0.98
	G1NA048S21D	1.02	1.04	0.99
	G1UA048S21	0.99	1.00	0.98
	G1FA048S21	0.99	1.00	0.98

HEATING PERFORMANCE DATA										
CONDENSING UNIT MODEL NO		EBBA-F048S, EBBA-(T,W)048S								
EVAPORATOR COIL MODEL NO		F2RP/F2FP048								
AIR TEMP. ENTERING OUTDOOR UNIT	AIR TEMP. ENTERING INDOOR COIL	ID CFM								
		1250			1400			1550		
		MBTUH	KW	C.O.P.	MBTUH	KW	C.O.P.	MBTUH	KW	C.O.P.
60	60	53.4	4.86	3.23	52.9	4.72	3.28	52.2	4.25	3.61
	70	54.2	4.76	3.34	54.1	4.61	3.44	53.7	4.14	3.80
	80	54.1	5.57	2.85	54.4	5.39	2.96	54.4	4.83	3.30
47	60	47.0	4.54	3.03	46.6	4.45	3.07	46.5	4.05	3.36
	70	46.9	4.56	3.02	47.0	4.47	3.08	47.2	4.06	3.41
	80	46.3	5.24	2.59	46.9	5.13	2.68	47.3	4.65	2.98
40	60	37.7	3.54	3.12	42.9	4.31	2.92	43.4	3.93	3.24
	70	37.3	3.98	2.75	42.9	4.40	2.86	42.6	4.13	3.02
	80	36.6	5.79	1.85	42.5	5.00	2.50	40.0	5.47	2.14
30	60	37.7	4.01	2.76	38.7	4.03	2.82	37.9	3.70	3.00
	70	36.7	4.16	2.58	38.2	4.22	2.65	38.4	3.93	2.86
	80	35.3	4.60	2.25	37.3	4.70	2.33	38.7	4.44	2.55
17	60	32.2	3.67	2.57	32.7	3.68	2.61	33.0	3.40	2.85
	70	30.8	3.98	2.27	31.4	3.97	2.32	31.8	3.66	2.55
	80	29.4	4.30	2.00	30.1	4.29	2.06	30.6	3.94	2.28
10	60	29.2	3.46	2.48	29.6	3.46	2.51	30.1	3.19	2.77
	70	27.5	3.81	2.12	27.9	3.80	2.15	28.4	3.51	2.37
	80	25.8	4.02	1.88	26.3	4.02	1.92	26.7	3.71	2.12

NOTE: ALL CAPACITIES INCLUDE INDOOR FAN HEAT AT 1250 BTUH/1000 CFM.

Multipliers for determining the performance with other indoor sections.

1 PHASE

Air Handler	Coil	MBH	KW	COP
N1AHC1606	G2FD048(S,H)21	1.00	1.02	0.98
N1AHD2006	G2FD048(S,H)24	1.00	1.02	0.98
N1AHD2006	G2FD060(S,H)24	1.00	1.03	0.97
F2FP060		1.01	1.02	0.99
	G2FD048(S,H)21,24	1.00	1.02	0.98
	G2FD060(S,H)24	1.00	1.03	0.97
	G1HD048	1.00	1.03	0.97
	G1HD060	1.00	1.03	0.97
	G1NA048S21D	1.00	1.04	0.96
	G1UA048S21	1.00	1.03	0.97
	G1UA060S21,24	1.00	1.03	0.97
	G1FA048S21	1.00	1.03	0.97
	G1FA060S21,24	1.00	1.03	0.97

3 PHASE

Air Handler	Coil	MBH	KW	COP
N1AHC1606	G2FD048(S,H)21	1.00	1.02	0.98
N1AHD2006	G2FD048(S,H)24	1.00	1.02	0.98
F2FP060		1.01	1.02	0.99
	G2FD048(S,H)21,24	1.00	1.02	0.98
	G1NA048S21D	1.00	1.04	0.96
	G1UA048S21	1.00	1.03	0.97
	G1FA048S21	1.00	1.03	0.97

HEATING PERFORMANCE DATA										
CONDENSING UNIT MODEL NO		EABA-F060S								
EVAPORATOR COIL MODEL NO		F2FP060								
AIR TEMP. ENTERING OUTDOOR UNIT	AIR TEMP. ENTERING INDOOR COIL	ID CFM								
		1550			1750			1950		
		MBTUH	KW	C.O.P.	MBTUH	KW	C.O.P.	MBTUH	KW	C.O.P.
60	60	64.7	5.61	3.38	62.9	5.42	3.41	61.1	5.26	3.40
	70	66.2	5.85	3.32	64.9	5.64	3.38	63.5	5.47	3.40
	80	66.2	6.83	2.84	65.4	6.54	2.93	64.4	6.34	2.98
47	60	56.3	5.41	3.05	55.9	5.27	3.11	53.9	5.18	3.05
	70	56.8	5.64	2.95	57.0	5.50	3.04	55.3	5.42	3.00
	80	56.3	6.44	2.56	57.0	6.27	2.66	55.8	6.17	2.65
40	60	52.4	5.17	2.97	53.0	5.19	2.99	50.8	5.13	2.91
	70	52.9	5.57	2.79	53.0	5.52	2.82	52.5	5.49	2.81
	80	52.6	6.22	2.48	52.1	6.07	2.52	53.3	6.06	2.58
30	60	48.6	5.12	2.78	48.9	5.07	2.83	48.7	5.01	2.85
	70	47.3	5.55	2.50	47.7	5.49	2.55	47.8	5.45	2.57
	80	45.4	5.88	2.27	46.0	5.80	2.33	46.5	5.78	2.36
17	60	37.5	4.67	2.36	38.6	4.72	2.40	36.5	4.71	2.27
	70	36.3	4.93	2.16	37.4	4.95	2.22	35.6	4.94	2.11
	80	35.2	5.30	1.95	36.2	5.26	2.02	34.7	5.26	1.93
10	60	33.0	4.50	2.15	34.3	4.52	2.22	34.6	4.50	2.25
	70	31.5	4.72	1.95	32.6	4.73	2.02	33.0	4.73	2.04
	80	30.2	4.89	1.81	31.1	4.90	1.86	31.6	4.91	1.89

NOTE: ALL CAPACITIES INCLUDE INDOOR FAN HEAT AT 1250 BTUH/1000 CFM.

Multipliers for determining the performance with other indoor sections.

Air Handler	Coil	MBH	KW	COP
N1AHD2006	G2FD060(S,H)24	0.99	0.97	1.02
	G2FD060(S,H)24	0.99	0.97	1.02
	G1HD060	1.00	0.98	1.02
	G1NA060S24T	1.02	0.98	1.04
	G1UA060S21,24	0.99	0.97	1.02
	G1FA060S21,24	0.99	0.97	1.02

HEATING PERFORMANCE DATA										
CONDENSING UNIT MODEL NO		EABA-(T,W)060S								
EVAPORATOR COIL MODEL NO		G2FD060(S,H)24								
AIR TEMP. ENTERING OUTDOOR UNIT	AIR TEMP. ENTERING INDOOR COIL	ID CFM								
		1600			1800			2000		
		MBTUH	KW	C.O.P.	MBTUH	KW	C.O.P.	MBTUH	KW	C.O.P.
60	60	63.6	5.09	3.67	61.9	4.98	3.64	60.1	4.87	3.62
	70	64.8	5.33	3.56	63.5	5.18	3.59	62.2	5.04	3.62
	80	65.9	5.60	3.45	65.1	5.39	3.54	64.2	5.20	3.62
47	60	56.9	4.15	4.03	55.7	4.02	4.06	54.4	3.90	4.10
	70	58.3	4.62	3.70	58.0	4.54	3.75	56.3	4.35	3.80
	80	59.7	5.19	3.38	59.0	5.03	3.44	58.2	4.88	3.50
40	60	54.5	4.05	3.95	53.3	3.93	3.97	52.0	3.81	4.00
	70	53.7	4.41	3.57	53.4	4.32	3.63	53.2	4.22	3.69
	80	52.9	4.87	3.19	53.6	4.78	3.29	54.3	4.71	3.38
30	60	49.6	3.89	3.74	49.8	3.80	3.84	49.9	3.72	3.93
	70	47.7	4.18	3.34	48.0	4.10	3.44	48.4	4.02	3.53
	80	45.8	4.57	2.94	46.3	4.47	3.04	46.8	4.39	3.13
17	60	40.6	3.56	3.34	41.0	3.51	3.42	41.3	3.46	3.50
	70	38.8	3.86	2.94	39.2	3.80	3.02	39.7	3.74	3.11
	80	36.9	4.26	2.54	37.5	4.18	2.63	38.0	4.10	2.71
10	60	36.3	3.53	3.01	36.7	3.46	3.11	37.1	3.38	3.21
	70	34.3	3.82	2.63	34.7	3.74	2.72	35.2	3.67	2.81
	80	32.2	4.19	2.25	32.7	4.12	2.33	33.2	4.05	2.40

NOTE: ALL CAPACITIES INCLUDE INDOOR FAN HEAT AT 1250 BTUH/1000 CFM.

Multipliers for determining the performance with other indoor sections.

Air Handler	Coil	MBH	KW	COP
N1AHD2046	G2FD060(S,H)24	1.00	1.00	1.00
F2FP060	G1FA060S21,24	1.01	1.03	0.95
	G1FA060S21,24	1.00	1.00	1.00
	G1UA060S21,24	1.00	1.00	1.00

HEATING PERFORMANCE DATA										
CONDENSING UNIT MODEL NO		EABA-(T,W)090S								
EVAPORATOR COIL MODEL NO		FCEH090								
AIR TEMP. ENTERING OUTDOOR UNIT	AIR TEMP. ENTERING INDOOR COIL	ID CFM								
		1550			1750			1950		
		MBTUH	K.W.	C.O.P.	MBTUH	K.W.	C.O.P.	MBTUH	K.W.	C.O.P.
60	60	94.5	8.93	3.10	91.9	8.63	3.13	89.2	8.38	3.12
	70	96.7	9.32	3.04	94.8	8.98	3.10	92.8	8.72	3.12
	80	96.7	10.88	2.61	95.5	10.42	2.69	94.1	10.10	2.73
47	60	82.3	8.61	2.80	81.7	8.39	2.86	78.7	8.25	2.80
	70	83.0	8.99	2.71	83.3	8.76	2.79	80.9	8.63	2.75
	80	82.2	10.26	2.35	83.2	9.99	2.44	81.5	9.83	2.43
40	60	76.5	8.23	2.73	77.4	8.27	2.75	74.3	8.17	2.67
	70	77.3	8.86	2.56	77.4	8.78	2.58	76.7	8.74	2.58
	80	76.9	9.91	2.28	76.2	9.67	2.31	78.0	9.65	2.37
30	60	71.0	8.15	2.55	71.4	8.07	2.60	71.1	7.99	2.61
	70	69.1	8.85	2.29	69.8	8.74	2.34	69.9	8.69	2.36
	80	66.4	9.37	2.08	67.3	9.23	2.14	67.9	9.21	2.16
17	60	54.8	7.43	2.16	56.3	7.51	2.20	53.3	7.50	2.09
	70	53.1	7.86	1.98	54.0	7.88	2.05	52.0	7.87	1.94
	80	51.4	8.44	1.79	52.9	8.38	1.85	50.7	8.38	1.77
10	60	48.2	7.17	1.97	50.1	7.20	2.04	50.5	7.17	2.07
	70	46.0	7.52	1.79	47.6	7.54	1.85	48.2	7.53	1.88
	80	44.1	7.80	1.66	45.5	7.81	1.71	46.2	7.82	1.73

NOTE: ALL CAPACITIES INCLUDE INDOOR FAN HEAT AT 1250 BTUH/1000 CFM.

MATCHING INDOOR COMPONENTS

ADD-ON COILS - FOR FURNACE APPLICATIONS

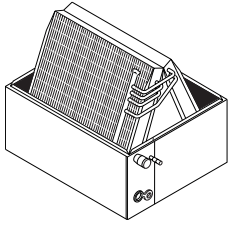

G1UA
UPFLOW

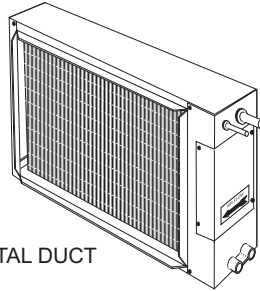

G1HD
HORIZONTAL DUCT

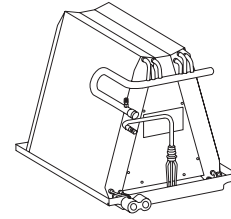

G1NA
UPFLOW

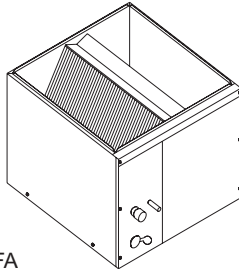

G1FA
FULL CASED

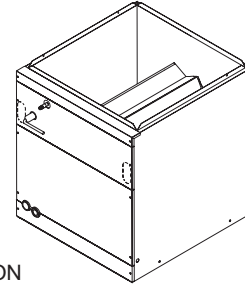

G2FD*
MULTI-POSITION
(UPFLOW, HORIZONTAL
AND DOWNFLOW)

* Available with factory installed horizontal drain pan.

AIR HANDLERS - FOR NON-FURNACE APPLICATIONS

N1AH OR N1VS
MODULAR BLOWER
(UPFLOW, HORIZONTAL
AND DOWNFLOW)

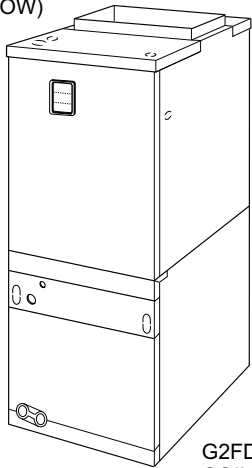

G2FD
COIL

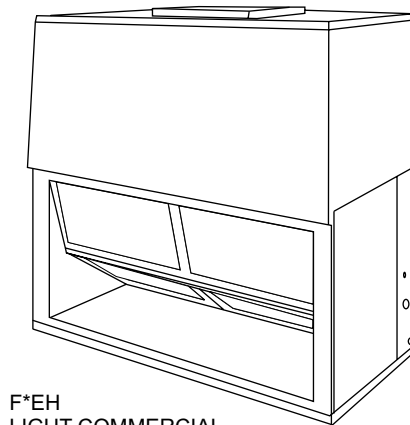

F*EH
LIGHT COMMERCIAL
APPLICATIONS

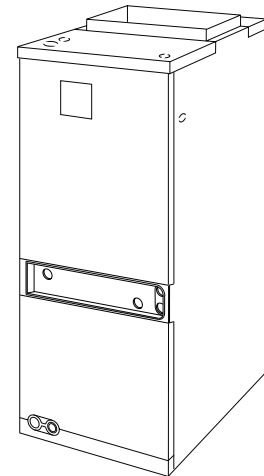

F2RC / F2FC OR
F2RC / F2FP
FAN COIL UNITS
(UPFLOW, HORIZONTAL)

NOTES

Subject to change without notice. Printed in U.S.A.
Copyright © by York International Corp. 2006. All rights reserved.

036-21318-002 Rev. A (0106)
Supersedes: 036-21318-001 Rev. C (0403)

**Unitary
Product
Group**

**5005
York
Drive**

**Norman
OK
73069**