

TECHNICAL GUIDE

MODELS: GM9S*UP

GAS-FIRED CONDENSING / HIGH EFFICIENCY UPFLOW FURNACES

92% TO 94% AFUE

NATURAL GAS
40 - 135 MBH INPUT



ISO 9001
Certified Quality
Management System

Due to continuous product improvement, specifications are subject to change without notice.

Visit us on the web at www.york.com for the most up-to-date technical information.

Additional rating information can be found at www.gamanet.org.

DESCRIPTION

These Category IV, highly efficient, compact, condensing type furnaces are designed for residential and commercial installations in a basement, closet, alcove, recreation room or garage where the ambient temperature is above 32°F, or higher. They may be either side wall or thru-roof vented using approved plastic type combustion air and vent piping. All units are factory assembled, wired and tested to assure dependable and economical installation and operation.

WARRANTY

Lifetime limited warranty on both heat exchangers to the original purchaser; a 20-year limited warranty from original installation date to subsequent purchaser.

10-year warranty on the heat exchanger in commercial applications.

5-year limited parts warranty.

FEATURES

- Compact, easy to install, ideal height 40" cabinet
- Blower-off delay for cooling SEER improvement.
- Easy to connect power/control wiring.
- Built-in, high level self diagnostics with fault code display.
- Low unit amp requirement for easy replacement application.
- Integrated control module for reliable, economical operation.
- May be installed as either two-pipe (sealed combustion) or single pipe vent (using indoor combustion air)
- Top intake & vent connection allows installation in narrow locations.
- Electronic Hot Surface Ignition saves fuel cost with increased dependability and reliability.
- Induced combustion system with inshot main burners for quiet, efficient operation.
- No special vent termination kit required.
- 100% shut off main gas valve for extra safety.
- PSC four speed, direct drive motor with large, quiet blower.
- 24V, 40 VA control transformer and blower relay supplied for add-on cooling.
- Hi-tech tubular aluminized steel primary heat exchanger.
- Secondary (condensing) heat exchanger of 29-4C high-grade stainless steel.
- Timed on, adjustable off blower capability for maximum comfort.
- Solid removable bottom panel allows easy application.
- Easy access from front of unit for cleaning, maintenance or service.
- Protection from intake, exhaust or condensate blockage.

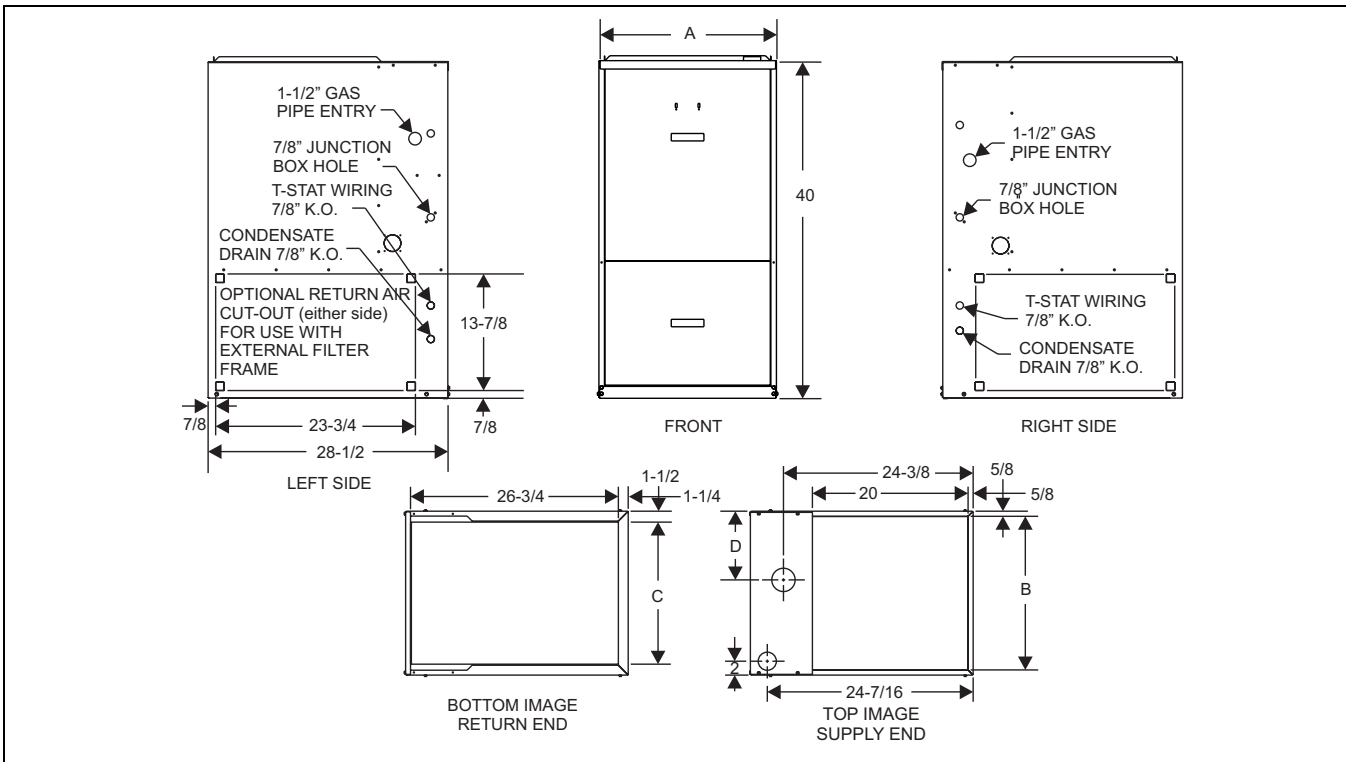

Models	Nominal CFM	Cabinet Size	Cabinet Dimension			
			A (in.)	B (in.)	C (in.)	D (in.)
GM9S040A12UP11	1200	A	14-1/2	13-1/4	11-1/2	6-1/4
GM9S060B12UP11	1200	B	17-1/2	16-1/4	14-1/2	8-1/2
GM9S080B12UP11	1200	B	17-1/2	16-1/4	14-1/2	8-1/2
GM9S080C16UP11	1600	C	21	19-3/4	18	8-7/8
GM9S080C20UP11	2000	C	21	19-3/4	18	8-7/8
GM9S100C16UP11	1600	C	21	19-3/4	18	8-7/8
GM9S100C20UP11	2000	C	21	19-3/4	18	8-7/8
GM9S120D20UP11	2000	D	24-1/2	23-1/4	21-1/2	10-5/8
GM9S135D20UP11	2000	D	24-1/2	23-1/4	21-1/2	10-5/8

ELECTRICAL AND PERFORMANCE DATA

Model	Input/ Cabinet	Output	Nominal Airflow	Cabinet Width	Total Unit	AFUE	Air Temp. Rise
	MBH	MBH	CFM	In.	Amps	%	°F
GM9S040A12UP11	40/A	38	1200	14-1/2	9	94.0	35 - 65
GM9S060B12UP11	60/B	56	1200	17-1/2	9	92.0	40 - 70
GM9S080B12UP11	80/B	74	1200	17-1/2	9	92.0	45 - 75
GM9S080C16UP11	80/C	75	1600	21	12	92.0	45 - 75
GM9S080C20UP11	80/C	75	2000	21	14	92.0	40 - 70
GM9S100C16UP11	100/C	93	1600	21	12	92.0	45 - 75
GM9S100C20UP11	100/C	93	2000	21	14	92.0	40 - 70
GM9S120D20UP11	120/D	112	2000	24-1/2	14	92.0	40 - 70
GM9S135D20UP11	135/D	127	2000	24-1/2	14	92.0	45 - 75

Model	Input/ Cabinet	Max. Outlet Air Temp.	Blower		Blower Size	Max. Over-current Protect	Min. Wire Size (awg) @ 75 ft. One Way	Operating Weight
	MBH	°F	HP	Amps	In.			Lbs.
GM9S040A12UP11	40/A	165	1/2	7.0	11 x 8	20	14	119
GM9S060B12UP11	60/B	170	1/2	7.0	11 x 8	20	14	133
GM9S080B12UP11	80/B	175	1/2	7.0	11 x 8	20	14	140
GM9S080C16UP11	80/C	175	3/4	10.2	11 x 10	20	14	155
GM9S080C20UP11	80/C	170	1	12.7	11 x 11	20	12	157
GM9S100C16UP11	100/C	175	3/4	10.2	11 x 10	20	14	160
GM9S100C20UP11	100/C	170	1	12.7	11 x 11	20	12	162
GM9S120D20UP11	120/D	170	1	12.7	11 x 11	20	12	178
GM9S135D20UP11	135/D	175	1	12.7	11 x 11	20	12	178

Nominal external static pressure is 0.50" w.c. at furnace outlet ahead of cooling coils.

Annual Fuel Utilization Efficiency (AFUE) numbers are determined in accordance with DOE Test procedures.

Wire size and over current protection must comply with the National Electrical Code (NFPA-70-latest edition) and all local codes.

NOTES:

1. For altitudes above 2000 ft. reduce capacity 4% for each 1000 ft. above sea level.
2. Wire size based on copper conductors, 60°C, 3% voltage drop.
3. Continuous return air temperature must not be below 55°F.

BLOWER PERFORMANCE CFM

Airflow with Bottom or One Side Return - without Filters (CFM)											
MODELS	Speed Tap	External Static Pressure, Inches W.C									
		0.1	0.2	0.3	0.4	0.5	0.6	0.7	0.8	0.9	1.0
GM9S040A12UP11	HIGH	1635	1590	1535	1480	1415	1340	1280	1185	NR	NR
	M-HI	1245	1225	1205	1185	1160	1110	1065	995	NR	NR
	M-LO	1005	1000	995	975	955	925	885	825	NR	NR
	LOW	775	770	765	750	725	680	655	620	NR	NR
GM9S060B12UP11 GM9S080B12UP11	HIGH	1650	1605	1570	1525	1465	1410	1350	1275	1170	1060
	M-HI	1165	1185	1175	1165	1150	1140	1100	1050	970	875
	M-LO	895	915	935	940	940	920	905	860	815	750
	LOW	710	725	725	725	720	700	685	660	625	560
GM9S080C20UP11 GM9S100C20UP11	HIGH	2300	2210	2120	2020	1930	1830	1715	1595	1480	1350
	M-HI	1950	1900	1830	1755	1680	1595	1500	1390	1270	1155
	M-LO	1610	1545	1490	1440	1390	1315	1230	1155	1050	920
	LOW	1325	1270	1225	1175	1105	1045	990	905	890	790
GM9S080C16UP11 GM9S100C16UP11	HIGH	1960	1955	1925	1890	1830	1765	1695	1615	1600	1485
	M-HI	1565	1560	1560	1575	1545	1530	1475	1425	1365	1260
	M-LO	1230	1275	1285	1300	1310	1300	1280	1245	1190	1070
	LOW	930	945	965	975	975	975	975	950	910	850
GM9S120D20UP11 GM9S135D20UP11	HIGH	2560	2485	2410	2320	2220	2135	2035	1920	1785	1650
	M-HI	2090	2050	1990	1970	1885	1820	1760	1675	1545	1405
	M-LO	1695	1675	1665	1615	1565	1510	1460	1385	1285	1140
	LOW	1175	1150	1135	1110	1085	1055	1005	980	970	845
Airflow with Two Side Returns or with Bottom and One Side Return - Without Filters (CFM)											
MODELS	Speed Tap	External Static Pressure, Inches W.C.									
		0.1	0.2	0.3	0.4	0.5	0.6	0.7	0.8	0.9	1.0
GM9S080C20UP11 GM9S100C20UP11	HIGH	2465	2380	2295	2195	2095	1995	1875	1760	1620	1470
	M-HI	2085	2035	1960	1880	1800	1705	1605	1485	1360	1235
	M-LO	1725	1625	1595	1540	1485	1405	1315	1235	1125	995
	LOW	1420	1360	1310	1255	1180	1120	1070	970	950	845
GM9S120D20UP11 GM9S135D20UP11	HIGH	2615	2535	2450	2385	2285	2175	2075	1945	1825	1670
	M-HI	2055	2045	2015	1985	1932	1855	1785	1730	1605	1470
	M-LO	1690	1650	1620	1600	1570	1525	1470	1395	1300	1200
	LOW	1345	1335	1335	1285	1250	1230	1180	1115	1010	850

NOTES:

1. Airflow expressed in standard cubic feet per minute (CFM).
2. Return air is through side opposite motor (left side) for one side return (worst case).
3. Airflows above 1800 CFM require either return from two sides or one side plus bottom.
4. Motor voltage at 115 V.
5. NR = Operation at this static pressure is not recommended.

FILTER PERFORMANCE

The airflow capacity data published in the “Blower Performance” table listed above represents blower performance WITHOUT filters. To determine the approximate blower performance of the system, apply the filter drop value for the filter being used or select an appropriate value from the “Filter Performance” table shown below.

NOTE: The filter pressure drop values in the “Filter Performance” table shown below are typical values for the type of filter listed and should only be used as a guideline. Actual pressure drop ratings for each filter type vary between filter manufacturer.

RECOMMENDED FILTER SIZES

Nominal CFM	Cabinet Size	Side Return Filter in.	Bottom Return Filter in. (cm)
1200	A	16 x 25	14 x 25
1200	B	16 x 25	16 x 25
1600	C	16 x 25	20 x 25
2000	C	16 x 25	20 x 25
2000	D	(2) 16 x 25	22 x 25

NOTES:

1. Air velocity through throwaway type filters may not exceed 300 feet per minute. All velocities over this require the use of high velocity filters.
2. Air flows above 1800 CFM require either return from two sides or one side plus bottom.

FILTER PERFORMANCE - PRESSURE DROP INCHES W.C. AND (KPA)

Airflow Range CFM	Minimum Opening Size in ²	Filter Type		
		Disposable In W.C.	Washable Fiber In W.C.	Pleated In W.C.
0 - 750	230	0.01	0.01	0.15
751 - 1000	330	0.05	0.05	0.20
1001 - 1250	330	0.10	0.10	0.20
1251 - 1500	330	0.10	0.10	0.25
1501 - 1750	380	0.15	0.14	0.30
1751 - 2000	380	0.19	0.18	0.30
2001 & Above	463	0.19	0.18	0.30

UNIT CLEARANCES TO COMBUSTIBLES

Application	Top	Front	Rear	Left Side	Right Side	Flue	Floor/ Bottom	Closet Alcove	Attic
	In.	In.	In.	In.	In.	In.			
Upflow	1	3	0	0	0	0	Combustible	Yes	Yes

For additional connection diagrams for all UPG equipment refer to "Low Voltage System Wiring" document available online at www.upgnet.com in the Product Catalog Section.

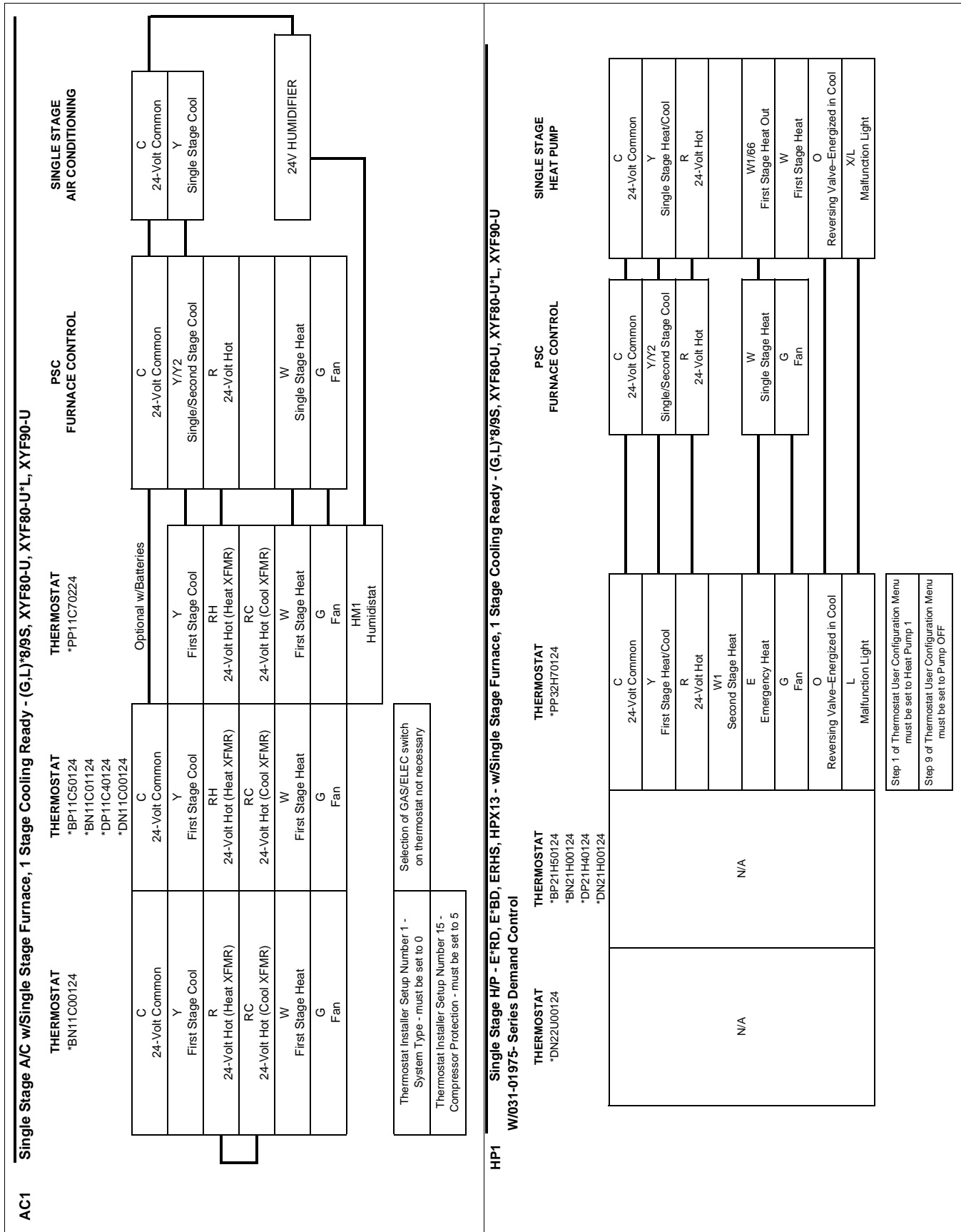

Thermostat Chart

APPLYING FILTER PRESSURE DROP TO DETERMINE SYSTEM AIRFLOW

To determine the approximate airflow of the unit with a filter in place, follow the steps below:

1. Select the filter type.
2. Select the number of return air openings or calculate the return opening size in square inches to determine the proper filter pressure drop.
3. Determine the External System Static Pressure (ESP) without the filter.
4. Select a filter pressure drop from the table based upon the number of return air openings or return air opening size and add to the ESP from Step 3 to determine the total system static.
5. If total system static matches a ESP value in the airflow table (i.e. 0.20, 0.60, etc.) the system airflow corresponds to the intersection of the ESP column and Model/ Blower Speed row.
6. If the total system static falls between ESP values in the table (i.e. 0.58, 0.75, etc.), the static pressure may be rounded to the nearest value in the table determining the airflow using Step 5 or calculate the airflow by using the following example.

Example: For a 120,000 Btuh furnace with 2 return openings and operating on high speed blower, it is found that total system static is 0.58" w.c. To determine the system airflow, complete the following steps:

1. Obtain the airflow values at 0.50" & 0.60" ESP.
Airflow @ 0.50": 2285 CFM
Airflow @ 0.60": 2175 CFM
2. Subtract the airflow @ 0.50" from the airflow @ 0.60" to obtain airflow difference.
 $2175 - 2285 = -110$ CFM
3. Subtract the total system static from 0.50" and divide this difference by the difference in ESP values in the table, 0.60" - 0.50", to obtain a percentage.
 $(0.58 - 0.50) / (0.60 - 0.50) = 0.8$
4. Multiply percentage by airflow difference to obtain airflow reduction.
 $(0.8) \times (-110) = -88$
5. Subtract airflow reduction value to airflow @ 0.50" to obtain actual airflow @ 0.58" ESP.
 $2285 - 88 = 2197$

ACCESSORIES

PROPANE (LP) CONVERSION KIT -

1NP0347 - All Models

This accessory conversion kit may be used to convert natural gas units for propane (LP) operation. Conversions must be made by qualified distributor or dealer personnel.

CONCENTRIC VENT TERMINATION -

1CT0302 (2")

1CT0303 (3")

For use through rooftop, sidewall. Allows combustion air to enter and exhaust to exit through single common hole. Eliminates unsightly elbows for a cleaner installation.

SIDEWALL VENT TERMINATION KIT -

1HT0901 (3")

1HT0902 (2")

For use on sidewall, two-pipe installations only. Provide a more attractive termination for locations where the terminal is visible on the side of the home.

CONDENSATE NEUTRALIZER KIT - 1NK0301

Neutralizer cartridge has a 1/2" plastic tube fittings for installation in the drain line. Calcium carbonate refill media is also available from the Source 1 Parts (p/n 026-30228-000).

EXTERNAL SIDE RETURN FILTER RACK -

1SF0101 - Fits all cabinet sizes

Attaches to side of furnace cabinet in side return applications. Holds any 16x25x1 permanent or disposable filter.

SIDE RETURN FILTER -

1SR0302 - All Models

1SR0200 - All Models

BOTTOM RETURN FILTER -

1BR0114 or 1BR0214 - For 14-1/2" cabinets

1BR0117 or 1BR0217 - For 17-1/2" cabinets

1BR0121 or 1BR0221 - For 21" cabinets

1BR0124 or 1BR0224 - For 24-1/2" cabinets

HIGH ALTITUDE PRESSURE SWITCHES -

For installation where the altitude is less than 8,000 feet it is not required that the pressure switch be changed. For altitudes above 8,000 feet see kits below. Conversion must be made by qualified distributor or dealer personnel.

1PS0307 - 080, 100 MBH

1PS0309 - 060, 120 MBH

1PS0322 - 040, 135 MBH

ROOM THERMOSTATS - A wide selection of compatible thermostats are available to provide optimum performance and features for any installation.

1H/1C, manual change-over electronic non-programmable thermostat.

1H/1C, auto/manual changeover, electronic programmable, deluxe 7-day, thermostat.

1H/1C, auto/manual changeover, electronic programmable.

* For the most current accessory information, refer to the price book or consult factory.

NOTES