

SUBMITTAL DATA SHEET

**R-22 SPLIT SYSTEM CONDENSING UNITS
1 THRU 5 TONS
MODELS: 13 SEER TCGD12 THRU 60**

JOB NAME:			LOCATION:		
PURCHASER:			ORDER NO:		
ENGINEER:					
SUBMITTED TO:	FOR:	REF:	APPROVAL:	CONSTRUCTION:	
SUBMITTED BY:			DATE:		
UNIT DESIGNATION:			SCHEDULE NO.	MODEL NO.	

PRODUCT DATA

Cooling Performance

Total Capacity _____ MBH

Outdoor Design Temp _____ °F

Electrical Data

Power Supply ____ / ____ / ____

Compressor Ampacity _____ AMPs

Total Unit Ampacity _____ AMPs

Power Input Req _____ KW

Minimum Wire Size _____ AWG

Overcurrent Device

Fuses Circuit Breaker

Unit Weight

Unit Weight _____ LBS

DIMENSIONS - INCHES

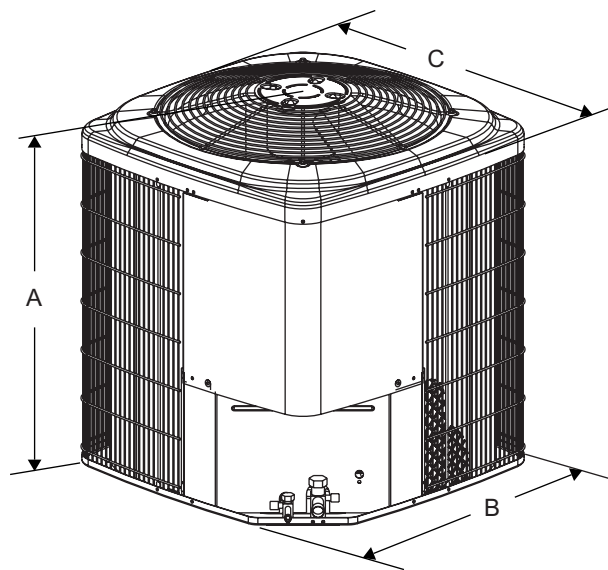

All dimensions are in inches. They are subject to change without notice. Certified dimensions will be provided upon request.



Unit Model	Dimensions (Inches)			Refrigerant Connection Service Valve Size	
	A ¹	B	C	Liquid	Vapor
12	24	23-1/2	23-1/2	3/8"	3/4"
18	28	23-1/2	23-1/2		
24	28	23-1/2	23-1/2		
30	32	23-1/2	23-1/2		
36	34	23-1/2	23-1/2		
42	34	29	29	7/8"	7/8" ²
48	34	29	29		
60	40	29	29		

1. Including Fan guard.
2. Expander fitting required for 1-1/8" linset.

FEATURES

- UL approval (units & accessories)
- CUL listed.
- Certified in accordance with the Unitary Small Equipment certification program, which the ARI Standard 210/240.
- 5-year limited parts warranty.
- 5-year limited warranty on the compressor.
- All aluminum coil
- Internally protected compressor.
- Propeller type fan.
- Durable construction.
- Pre-painted steel cabinet.
- Factory wired.
- Sweat refrigerant connections.
- Re-useable brass service valves.
- Easy access to electrical compartment.
- Liquid line filter dryer.
- Powder coated fan guard and coil guard.
- 18 gauge G90 galvanized formed base pan.

CLEARANCES

Service Access	18 Inches
All Other Sides	6 Inches
Above Unit	60 Inches
Below Unit	0 Inches

MATCHING AIR SIDE EQUIPMENT

Model No. _____

Submittal Form No. _____

FIELD INSTALLED ACCESSORIES

Off Cycle Timer (2TD08700124) _____

Thermostats _____

Blower Off Delay (2FD06700224) _____

Hard Start Kit _____

Model	Source 1 Kit numbers
12	S1-2SA06708606
18	S1-2SA06708606
24	S1-2SA06708706
30	S1-2SA06705906
36	S1-2SA06708106
42	S1-2SA06708106
48	S1-2SA06708707

NOTES:
