

SUBMITTAL DATA SHEET

R-410A SPLIT SYSTEM HEAT PUMP UNITS
1.5 THRU 5 TONS
MODELS: 13 SEER CPBD018*Thru 060*

JOB NAME:			LOCATION:		
PURCHASER:			ORDER NO.:		
ENGINEER:					
SUBMITTED TO:	FOR:	REF:	APPROVAL:	CONSTRUCTION:	
SUBMITTED BY:			DATE:		
UNIT DESIGNATION:			SCHEDULE NO.	MODEL NO.	

PRODUCT DATA

Cooling Performance

Total Capacity _____ MBH
 Outdoor Design Temp _____ °F

Electrical Data

Power Supply ____ / ____ / ____
 Total Unit Ampacity _____ AMPs
 Power Input Req _____ KW
 Minimum Wire Size _____ AWG
 Overcurrent Device
 Fuses Circuit Breaker

Unit Weight

Unit Weight _____ LBS

DIMENSIONS - INCHES

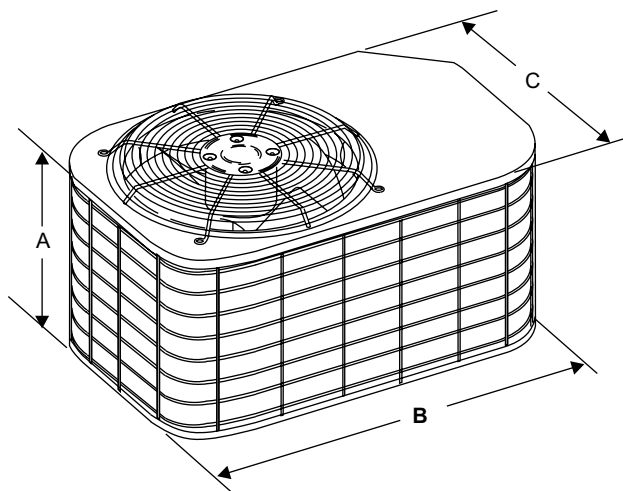

All dimensions are in inches. They are subject to change without notice. Certified dimensions will be provided upon request.



Unit Model	Dimensions (Inches)			Refrigerant Connection Service Valve Size	
	A ¹	B	C	Liquid	Vapor
018	27	37	27	3/8"	3/4"
024	31	37	27		
030	35	37	27		
036	39	37	27		7/8"
042	39	37	27		
048	38	43	32		
060	34	43	32		

1. Including Fan Guard.

FEATURES

- UL and CUL listed approval (units & accessories).
- Certified in accordance with the Unitary Small Equipment certification program, which the ARI Standard 210/240.
- 5-year limited parts warranty.
- 5-year limited warranty on the compressor.
- Copper tube aluminum fin coil.
- Internally protected compressor.
- Propeller type fan.
- Durable construction.
- Pre-painted steel cabinet.
- Factory wired and tested.
- Sweat refrigerant connections.
- Re-useable brass service valves.
- Easy access to electrical compartment.
- Liquid line filter dryer.
- PVC wire coated fan guard and 2" x 4" coil guard.
- 18 gauge G90 galvanized formed base pan.
- Condenser fan molex plug connector.

MATCHING AIR SIDE EQUIPMENT

Model No. _____
 Submittal Form No. _____

FIELD INSTALLED ACCESSORIES

Start Assist Kit _____
 Blower Time Delay _____
 Hard Start Kits - _____
 Low Temperature Cutout _____
 Compressor Blanket _____
 Add-on Fossil Fuel Control _____
 Thermal Expansion Valve Kit _____
 Outdoor Thermostat (2TD06700124) _____

CLEARANCES

Service Access	18 Inches
All Other Sides	10 Inches
Above Unit	48 Inches
Below Unit	0 Inches

NOTES:
