

SUBMITTAL DATA SHEET

R-22 SPLIT SYSTEM HEAT PUMP UNITS

3 THRU 5 TONS

MODELS: 10 SEER E*BA-(T,W)036 Thru 060, 3 PHASE

JOB NAME:			LOCATION:		
PURCHASER:			ORDER NO:		
ENGINEER:					
SUBMITTED TO:		FOR:	REF:	APPROVAL:	CONSTRUCTION:
SUBMITTED BY:			DATE:		
UNIT DESIGNATION:			SCHEDULE NO.	MODEL NO.	

PRODUCT DATA

Cooling Performance

Total Capacity _____ MBH

Outdoor Design Temp _____ °F

Electrical Data

Power Supply ____ / ____ / ____

Compressor Ampacity _____ AMPs

Total Unit Ampacity _____ AMPs

Power Input Req _____ KW

Minimum Wire Size _____ AWG

Overcurrent Device

Fuses Circuit Breaker

Unit Weight

Unit Weight _____ LBS

DIMENSIONS - INCHES

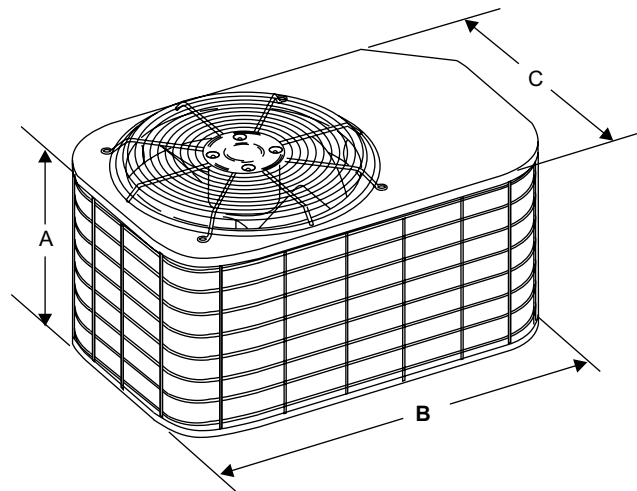

All dimensions are in inches. They are subject to change without notice. Certified dimensions will be provided upon request.

Unit Model	Dimensions (Inches)			Refrigerant Connection Service Valve Size	
	A ¹	B	C	Liquid	Vapor
036	27	37	27	3/8	3/4
048	33	37	27		7/8
060	26	43	32		7/8
090	32	43	32	1/2"	1-1/8"

1. Including Fan Guard.



FEATURES

- UL and CUL listed approval (units & accessories).
- Certified in accordance with the Unitary Small Equipment certification program, which the ARI Standard 210/240
- 1-year limited parts warranty
- 5-year limited warranty on the compressor
- Copper tube/coated black aluminum fins
- Time-temperature defrost control
- Condenser fan molex plug connector
- Internally protected compressor
- Suction line accumulator
- Top discharge propeller type fan
- PVC wire coated fan guard and 2" x 4" coil guard
- Pre-painted steel cabinet
- Standard solid core discharge line filter-drier
- R-22 total system charge (thru 15 ft of lines)
- Sweat connection with re-usable service valves

MATCHING AIR SIDE EQUIPMENT

Model No. _____
Submittal Form No. _____

FIELD INSTALLED ACCESSORIES

Start Assist Kit _____
Blower Time Delay _____
Hard Start Kits - _____
Low Temperature Cutout _____
Compressor Blanket _____
Add-on Fossil Fuel Control _____
Thermal Expansion Valve Kit _____
Outdoor Thermostat (2TD06700124) _____

CLEARANCES

Service Access	18 Inches
All Other Sides	10 Inches
Above Unit	48 Inches
Below Unit	0 Inches

NOTES:

Subject to change without notice. Printed in U.S.A.
Copyright © by Unitary Products Group 2007. All rights reserved.

347204-BSD-A-1207
Supersedes: 036-22529-001-A-0703

**Unitary
Products
Group**

**5005
York
Drive**

**Norman
OK
73069**