



TECHNICAL GUIDE

SPLIT-SYSTEM HEAT PUMPS

13 SEER – R-22

MODELS:
CHJD18 THRU 60
(1.5 THRU 5 NOMINAL TONS, 1 PHASE)



Due to continuous product improvement, specifications are subject to change without notice.

Visit us on the web at www.york.com

Additional rating information can be found at www.ahridirectory.org

DESCRIPTION

The heat pump condensing unit is the outdoor part of a versatile system of heating and air conditioning. It is designed to be custom-matched with one of UPG's complete line of evaporator sections, with each serving a specific function. Matching Air Handlers are available for upflow, downflow, or horizontal applications to provide a complete system. Electric Heaters are available, if required. Add-on coils are available for use with upflow, downflow, or horizontal furnaces and air handlers.

WARRANTY

Single Phase Units:

5-year limited parts warranty.

10-year limited compressor warranty.

FEATURES

- **QUALITY CONDENSER COILS** - The coil is constructed of copper tubing and enhanced aluminum fins for increased efficiency and corrosion protection.
- **PROTECTED COMPRESSOR** - The compressor is internally protected against high pressure, temperature, and externally by a factory installed high pressure switch. This is accomplished by the simultaneous operation of high pressure relief valve and a temperature sensor which protects the compressor if undesirable operating conditions occur. A liquid line filter-drier further protects the compressor.
- **DURABLE FINISH** - The cabinet is made of pre-painted steel. The pre-treated galvanized steel provides a better paint to steel bond, which resists corrosion and rust creep. Special primer formulas and matted-textured finish insure less fading when exposed to sunlight.
- **LOWER INSTALLED COST** - Installation time and costs are reduced by easy power and control wiring connections. Available in sweat connect models only. The unit contains enough refrigerant for matching indoor coils and 15 feet of interconnecting piping. The small base dimension means less space is required on the ground or roof.
- **TOP DISCHARGE** - The warm air from the top mounted fan is blown up away from the structure and any landscaping. This allows compact location on multi-unit applications.
- **LOW OPERATING SOUND LEVEL** - The upward air flow carries the normal operating noise away from the living area. The rigid top panel effectively isolates any motor sound. Isolator mounted compressor and the rippled fins of the condenser coil muffle the normal fan motor and compressor operating sounds.
- **LOW MAINTENANCE** - Long life permanently lubricated motor-bearings need no annual servicing.
- **EASY SERVICE ACCESS** - Fully exposed refrigerant connections, and a single panel covering the electrical controls make for easy servicing of the unit.
- **SECURED SERVICE VALVES** - Secured re-usable service valves are provided on both the liquid and vapor sweat connections for ease of evacuating and charging.
- **U.L. and C.U.L. listed** - approved for outdoor application.
- **Agency Listed** - U.L. and C.U.L. listed - approved for outdoor application. The unit is certified in accordance with the Unitary Small Equipment certification program, which is based on ARI Standard 210/240.

Physical and Electrical Data

MODEL	CHJD18 S21S1	CHJD24 S21S1	CHJD30 S21S1	CHJD36 S21S1	CHJD42 S21S1	CHJD48 S21S1	CHJD60 S21S1	
Unit Supply Voltage	208-230V, 1 ϕ , 60Hz							
Normal Voltage Range ¹	187 to 252							
Minimum Circuit Ampacity	9.9	13.1	17.7	19.8	24.9	30.3	38.3	
Max. Overcurrent Device Amps ²	15	20	30	30	40	50	60	
Min. Overcurrent Device Amps ³	15	15	20	20	25	35	40	
Compressor Type	Recip	Recip	Recip	Recip	Recip	Scroll	Scroll	
Compressor Amps	Rated Load	7.6	9.9	13.1	14.6	18.7	23.0	29.5
	Locked Rotor	36	54	61	78	78	115	150
Crankcase Heater	Yes	Yes	Yes	Yes	Yes	No	No	
Fan Motor Amps	Rated Load	0.5	1.5	1.4	1.5	1.5	1.5	
Fan Diameter Inches	24	24	24	24	24	24	24	
Fan Motor	Rated HP	1/15	1/10	1/4	1/4	1/4	1/4	
	Nominal RPM	850	825	1100	850	850	850	
	Nominal CFM	2050	2250	3700	3700	3600	3450	
Coil	Face Area Sq. Ft.	15.72	18.34	20.96	23.58	23.58	24.00	
	Rows Deep	1	1	1	1	1	2	
	Fin / Inches	22	22	22	22	22	22	
Liquid Line Set OD (Field Installed)	3/8	3/8	3/8	3/8	3/8	3/8	3/8	
Vapor Line Set OD (Field Installed)	3/4	3/4	3/4	7/8	7/8	7/8	1-1/8	
Unit Charge (Lbs. - Oz.) ⁴	7 - 3	7 - 7	8 - 12	9 - 1	11 - 14	13 - 4	15 - 5	
Charge Per Foot, Oz.	0.68	0.68	0.68	0.70	0.70	0.70	0.76	
Operating Weight Lbs.	172	184	196	208	208	275	280	

1. Rated in accordance with ARI Standard 110, utilization range "A".

2. Dual element fuses or HACR circuit breaker. Maximum allowable overcurrent protection.

3. Dual element fuses or HACR circuit breaker. Minimum recommended overcurrent protection.

4. The Unit Charge is correct for the outdoor unit, matched indoor coil and 15 feet of refrigerant tubing. For tubing lengths other than 15 feet, add or subtract the amount of refrigerant, using the difference in length multiplied by the per foot value.

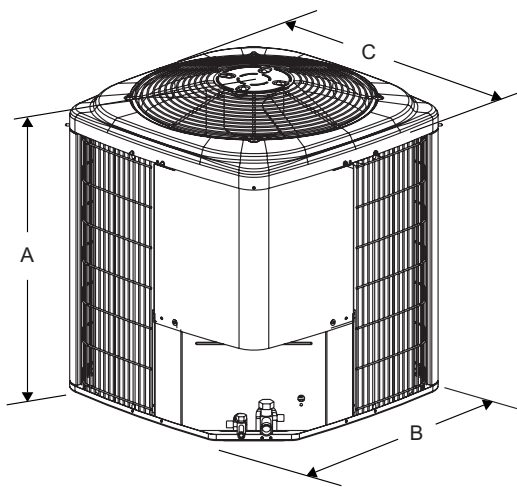

All dimensions are in inches. They are subject to change without notice. Certified dimensions will be provided upon request.

Unit Model	Dimensions (Inches)			Refrigerant Connection Service Valve Size	
	A ¹	B	C	Liquid	Vapor
18	28	34	34	3/8"	3/4"
24	32	34	34		
30	36	34	34		
36	40	34	34		7/8"
42	40	34	34		
48	40	34	34	1-1/8"	
60	40	34	34		

1. Including Fan Guard.

* Adapter fitting required for 1-1/8" line set.

Additional R-22 Charge / Orifice Size for Various Matched Systems							
Outdoor Unit	CHJD18 S21S1	CHJD24 S21S1	CHJD30 S21S1	CHJD36 S21S1	CHJD42 S21S1	CHJD48 S21S1	CHJD60 S21S1
Required Orifice or TXV ¹	1TVM2A1	1TVM2A1	1TVM2A1	1TVM2A1	1TVM2C1	1TVM2C1	1TVM2C1
Factory Charge, lbs-oz	7 - 3	7 - 7	8 - 12	9 - 1	11 - 14	13 - 4	15 - 5
Indoor Coil ^{2,3}	Additional Charge, Oz						
FC/MC/PC/UC18A2A	0	-	-	-	-	-	-
FC/MC/PC/UC18B2A	0	-	-	-	-	-	-
FC/MC/PC/UC24A2A	0	0	-	-	-	-	-
FC/MC/PC/UC24B2A	0	0	-	-	-	-	-
FC/MC/PC/UC30A2A	0	0	-	-	-	-	-
FC/MC/PC/UC30B2A	0	0	-	-	-	-	-
FC/MC/PC/UC32A2A	-	5	0	-	-	-	-
FC/MC/PC/UC35B2A	-	5	0	-	-	-	-
FC/MC/PC/UC35C2A	-	5	0	-	-	-	-
FC/MC/PC/UC37A2A	-	-	0	0	-	-	-
FC/MC/PC/UC43C2C	-	-	-	-	-	-	-
FC/MC/PC/UC48C2C	-	-	-	-	0	-	-
FC/MC/PC/UC48D2C	-	-	-	-	0	-	-
FC/PC/UC60C2C	-	-	-	-	2	0	-
FC/MC/PC/UC60D2C	-	-	-	-	2	0	-
FC/MC62D2C	-	-	-	-	-	2	0
HC18A2A	0	-	-	-	-	-	-
HC30A2A	-	0	-	-	-	-	-
HC36B2A	-	5	0	-	-	-	-
HC60C2C	-	-	-	-	2	0	-
HD24A2A	-	4	-	-	-	-	-
HD36B2A	-	-	0	-	-	-	-
HD60D2C	-	-	-	-	2	0	-
MH30S2A	-	6	-	-	-	-	-
AHP18B2A	0	-	-	-	-	-	-
AHP24B2A	0	0	-	-	-	-	-
AHP30B2A	-	5	0	-	-	-	-
AHP36C2A	-	-	0	0	-	-	-
AHP48D2C	-	-	-	-	2	0	-
AHP60D2C	-	-	-	-	2	0	-
AV24B2A	0	0	-	-	-	-	-
AV36C2A	-	-	0	0	-	-	-
AV48D2C	-	-	-	-	0	0	-
AV60D2C	-	-	-	-	0	0	-
FC/MC/PC/UC18A3X	2A + 0	-	-	-	-	-	-
FC/MC/PC/UC18B3X	2A + 0	-	-	-	-	-	-
FC/MC/PC/UC24A3X	2A + 0	2A + 0	-	-	-	-	-
FC/MC/PC/UC24B3X	2A + 0	2A + 0	-	-	-	-	-
FC/MC/PC/UC30A3X	-	2A + 0	-	-	-	-	-
FC/MC/PC/UC30B3X	-	2A + 0	-	-	-	-	-
FC/MC/PC/UC32A3X	-	2A + 5	2A + 0	-	-	-	-
FC/MC/PC/UC35B3X	-	2A + 5	2A + 0	-	-	-	-
FC/MC/PC/UC35C3X	-	2A + 5	2A + 0	-	-	-	-
FC/MC/PC/UC37A3X	-	-	2A + 0	2A + 0	-	-	-
FC/MC/PC/UC43B3X	-	-	2A + 0	2A + 0	-	-	-
FC/MC/PC/UC43C3X	-	-	2A + 0	2A + 0	-	-	-
FC/MC/PC/UC48C3X	-	-	-	2A + 3	2C + 0	-	-
FC/MC/PC/UC48D3X	-	-	-	2A + 3	2C + 0	-	-
FC/PC/UC60C3X	-	-	-	2A + 5	2C + 2	2C + 0	-

For Notes See Page 4.

Additional R-22 Charge / Orifice Size for Various Matched Systems (Continued)							
Outdoor Unit	CHJD18 S21S1	CHJD24 S21S1	CHJD30 S21S1	CHJD36 S21S1	CHJD42 S21S1	CHJD48 S21S1	CHJD60 S21S1
Required Orifice or TXV ¹	1TVM2A1	1TVM2A1	1TVM2A1	1TVM2A1	1TVM2C1	1TVM2C1	1TVM2C1
Factory Charge, lbs-oz	7 - 3	7 - 7	8 - 12	9 - 1	11 - 14	13 - 4	15 - 5
Indoor Coil ^{2,3}	Additional Charge, Oz						
FC/MC/PC/UC60D3X	-	-	-	2A + 5	2C + 2	2C + 0	-
FC/PC62D3X	-	-	-	-	-	2C + 2	2C + 0
HC18A3X	2A + 0	-	-	-	-	-	-
HC30A3X	-	2A + 0	-	-	-	-	-
HC36B3X	-	2A + 5	2A + 0	-	-	-	-
HC42C3X	-	-	2A + 0	2A + 0	-	-	-
HC60C3X	-	-	-	2A + 5	2C + 2	2C + 0	-
HD24A3X	-	2A + 4	-	-	-	-	-
HD36B3X	-	-	2A + 0	-	-	-	-
HD48C3X	-	-	-	2A + 3	-	-	-
HD60D3X	-	-	-	2A + 5	2C + 2	2C + 0	-
MH24S59	-	2A + 6	2A + 0	-	-	-	-
MH30S65	-	2A + 6	2A + 0	-	-	-	-
AHP18B3X	2A + 0	-	-	-	-	-	-
AHP24B3X	2A + 0	2A + 0	-	-	-	-	-
AHP30B3X	-	2A + 5	2A + 0	-	-	-	-
AHP36C3X	-	-	2A + 0	2A + 0	-	-	-
AHP42C3X	-	-	-	2A + 0	-	-	-
AHP48D3X	-	-	-	-	2C + 2	2C + 0	-
AHP60D3X	-	-	-	2A + 5	2C + 2	2C + 0	-
AV24B2A	2A + 0	2A + 0	-	-	-	-	-
AV36C2A	-	-	2A + 0	2A + 0	-	-	-
AV48D2C	-	-	-	2A + 0	2C + 0	2C + 0	-
AV60D2C	-	-	-	-	2C + 0	2C + 0	-
F4FP024	0	-	-	-	-	-	-
F4FP030	-	0	-	-	-	-	-
F4FP040	-	-	0	-	-	-	-
F5FP045	-	-	-	2A + 5	2	-	-
F5FP048	-	-	-	2A + 3	0	-	-
F5FP060	-	-	-	2A + 5	2	0	-
F4FV060	-	-	-	2A + 0	0	0	-

FOOTNOTES:

1. For applications requiring a TXV use 1TVM series kit.
2. Systems matched with furnace or air handlers not equipped with blower-off delays may require blower Time Delay Kit 2FD06700224.
3. PC coils cannot be used in downflow or horizontal applications. FC coils cannot be used in horizontal applications.

PROCEDURES:

1. Unit factory charge listed on the unit nameplate includes refrigerant for the condenser, the smallest evaporator and 15 feet of interconnecting line tubing.
2. Verify the TXV or orifice and additional charge required for specific evaporator coil in the system using the above table.
3. Additional charge for the amount of interconnecting line tubing greater than 15 feet at the rate specified in Physical and Electrical Data Table.
4. Permanently mark the unit nameplate with the total system charge. Total System Charge = Base Charge (as shipped) + adder for evaporator + adder for line set.

COOLING CAPACITY - With Air Handler Coils

UNIT MODEL	AIR HANDLER		COIL MODEL ¹	COOLING				
	MODEL	W		RATED CFM	NET MBH		SEER	EER
					TOTAL	SENS.		
13 SEER HP WITH MA								
CHJD18S21S1	MA08B	17	FC/MC18B	600	18.0	12.9	13.00	11.00
	MA08B	17	FC/MC24B	600	18.0	12.9	13.00	11.00
	MA08B	17	FC/MC30B	600	18.0	12.9	13.00	11.00
CHJD24S21S1	MA08B	17	FC/MC24B	800	23.0	16.8	13.00	11.00
	MA08B	17	FC/MC30B	800	23.0	16.8	13.00	11.00
	MA08B	17	FC/MC35B	800	23.0	16.8	13.00	11.00
CHJD30S21S1	MA12B	17	FC/MC35B	1000	29.0	21.2	13.00	11.00
	MA12B	17	FC/MC43B	1000	29.0	21.2	13.00	11.00
CHJD36S21S1	MA12B	17	FC/MC43B	1200	35.0	25.6	13.00	11.00
	MA14D	24	FC/MC48D	1200	35.0	25.6	13.00	11.00
	MA14D	24	FC/MC60D	1200	35.0	25.6	13.00	11.00
CHJD42S21S1	MA14D	24	FC/MC48D	1400	40.0	28.8	13.00	11.00
	MA16C	21	FC/MC48C	1400	40.0	28.8	13.00	11.00
	MA14D	24	FC/MC60D	1400	40.0	28.8	13.00	11.00
	MA16C	21	FC60C	1400	40.0	28.8	13.00	11.00
CHJD48S21S1	MA16C	21	FC60C	1600	45.0	33.2	13.00	11.00
	MA20D	24	FC/MC60D	1600	45.0	33.2	13.00	11.00
	MA20D	24	FC/MC62D	1600	45.0	33.2	13.00	11.00
CHJD60S21S1	MA20D	24	FC/MC62D	1800	55.0	40.0	13.00	11.00
13 SEER HP WITH MV - VARIABLE SPEED								
CHJD18S21S1	MV12B	17	FC/MC18B	600	18.0	13.3	14.00	12.00
	MV12B	17	FC/MC24B	600	18.0	13.4	14.00	12.00
	MV12B	17	FC/MC30B	600	18.0	13.4	14.00	12.00
CHJD24S21S1	MV12B	17	FC/MC24B	800	23.0	17.4	14.00	12.00
	MV12B	17	FC/MC30B	800	23.0	17.4	14.00	12.00
	MV12B	17	FC/MC35B	800	23.0	17.4	14.00	12.00
CHJD30S21S1	MV12B	17	FC/MC35B	1000	29.0	21.8	14.00	12.00
	MV16C	21	FC/MC35C	1000	29.0	22.0	14.00	12.00
	MV12B	17	FC/MC43B	1000	29.0	21.8	14.00	12.00
	MV16C	21	FC/MC43C	1000	29.0	22.0	14.00	12.00
CHJD36S21S1	MV12B	17	FC/MC43B	1200	35.0	26.2	14.00	12.00
	MV16C	21	FC/MC43C	1200	35.0	26.4	14.00	12.00
	MV16C	21	FC/MC48C	1200	35.0	26.4	14.00	12.00
	MV16C	21	FC60C	1200	35.0	26.4	14.00	12.00
	MV12D	24	FC/MC48D	1200	35.0	26.4	14.00	12.00
	MV12D	24	FC/MC60D	1200	35.0	26.4	14.00	12.00
CHJD42S21S1	MV16C	21	FC/MC48C	1400	41.0	29.4	13.85	11.00
	MV16C	21	FC/MC48C	1400	41.0	29.4	13.85	11.00
	MV20D	24	FC/MC48D	1400	41.0	29.4	13.85	11.00
	MV20D	24	FC/MC60D	1400	41.0	29.4	13.85	11.00
CHJD48S21S1	MV16C	21	FC60C	1200	45.0	33.2	13.25	11.00
	MV20D	24	FC/MC60D	1600	46.0	33.8	13.25	11.00
	MV20D	24	FC/MC62D	1600	45.0	33.6	13.30	11.00
CHJD60S21S1	MV20D	24	FC/MC62D	1800	55.0	40.5	13.50	11.00

For Notes See Page 6.

COOLING CAPACITY - With Air Handler Coils (Continued)

UNIT MODEL	AIR HANDLER		COIL MODEL ¹	COOLING				
	MODEL	W		RATED CFM	NET MBH		SEER	EER
					TOTAL	SENS.		
13 SEER HP WITH AV / SV / F*FV - VARIABLE SPEED								
CHJD18S21S1	AV24	17	—	565	18.0	13.4	14.00	12.00
CHJD24S21S1	AV24	17	—	770	23.0	17.5	14.00	12.00
CHJD30S21S1	AV36	21	—	1015	29.0	22.0	14.00	12.00
CHJD36S21S1	AV36	21	—	1270	35.0	26.2	14.00	12.00
	AV/SV48	24	—	1270	35.0	26.2	14.00	12.00
CHJD42S21S1	AV/SV48	24	—	1415	41.0	29.4	13.85	11.00
	AV/SV60	24	—	1410	41.0	29.4	13.85	11.00
	F4FV060	24	—	1410	41.0	29.4	13.85	11.00
CHJD48S21S1	AV/SV48	24	—	1610	46.0	33.8	13.25	11.00
	AV/SV60	24	—	1655	46.0	33.6	13.25	11.00
	F4FV060	24	—	1655	46.0	33.6	13.30	11.00
13 SEER HP WITH AHP / SHP / F*FP								
CHJD18S21S1	AHP18	17	—	650	18.0	12.9	13.00	11.00
	AHP24	17	—	655	18.0	13.0	13.00	11.00
	F4FP024	17	—	655	18.0	13.0	13.00	11.00
CHJD24S21S1	AHP24	17	—	830	23.0	16.9	13.00	11.00
	AHP30	17	—	795	23.0	16.8	13.00	11.00
	F4FP030	17	—	795	23.0	16.8	13.00	11.00
CHJD30S21S1	AHP30	17	—	1015	29.0	21.2	13.00	11.00
	AHP36	21	—	1040	29.0	21.2	13.00	11.00
	F4FP040	21	—	1040	29.0	21.2	13.00	11.00
CHJD36S21S1	AHP36	21	—	1235	35.0	25.6	13.00	11.00
	AHP42	21	—	1255	35.0	25.6	13.00	11.00
	AHP/SHP60	24	—	1270	35.0	26.2	14.00	12.00
	F4FP045	24	—	1200	35.0	25.6	13.00	11.00
	F5FP048	24	—	1200	35.0	26.2	14.00	12.00
	F5FP060	24	—	1200	35.0	26.2	14.00	12.00
CHJD42S21S1	AHP/SHP48	24	—	1400	40.0	29.0	13.00	11.00
	AHP/SHP60	24	—	1400	41.0	29.4	13.85	11.00
	F4FP045	24	—	1400	40.0	29.0	13.00	11.00
	F5FP048	24	—	1400	41.0	29.4	13.85	11.00
	F5FP060	24	—	1400	41.0	29.4	13.85	11.00
CHJD48S21S1	AHP/SHP48	24	—	1600	45.0	33.2	13.00	11.00
	AHP/SHP60	24	—	1600	46.0	33.6	13.30	11.00
	F5FP060	24	—	1600	46.0	33.6	13.30	11.00

Rated in accordance with DOE test procedures (Federal Register 12-27-79 and 3-18-88) and ARI Standards 210.

Cooling MBH based on 80°F entering air temperature, 50% RH, and rated air flow.

EER (Energy Efficiency Ratio) is the total cooling output in BTU's at 95°F outdoor ambient divided by the total electric power in watt-hours at those conditions.

SEER (Seasonal Energy Efficiency Ratio) is the total cooling output in BTU's during a normal annual usage period for cooling divided by the total electric power input in watt-hours during the same period.

1. MC coils available with a factory installed horizontal drain pan. See price pages for specific model number.
 — = Not applicable.

COOLING CAPACITY - Upflow, Downflow & Horizontal Furnaces and Coils

UNIT MODEL	FURNACE**		COIL MODEL	COOLING				
	CFM RANGE (Min.-max.)	W		RATED CFM	NET MBH		SEER ¹	EER
					TOTAL	SENS.		
CHJD18S21S1	450 - 750	14,17	FC/MC/PC/UC18	600	18.0	12.9	13.00	11.00
	450 - 750	14,17	FC/MC/PC/UC24	600	18.0	12.9	13.00	11.00
	450 - 750	14,17	FC/MC/PC/UC30	600	18.0	12.9	13.00	11.00
	450 - 750	14	HC18	600	18.0	12.9	13.00	11.00
CHJD24S21S1	600 - 1000	14,17	FC/MC/PC/UC24	800	23.0	16.8	13.00	11.00
	600 - 1000	14,17	FC/MC/PC/UC30	800	23.0	16.8	13.00	11.00
	600 - 1000	14	FC/MC/PC/UC32	800	23.0	16.8	13.00	11.00
	600 - 1000	17,21	FC/MC/PC/UC35	800	23.0	16.8	13.00	11.00
	600 - 1000	14	HC30	800	23.0	16.8	13.00	11.00
	600 - 1000	17	HC36	800	23.0	16.8	13.00	11.00
	600 - 1000	-	HD24	800	23.0	16.8	13.00	11.00
	600 - 1000	19	MH24S	800	23.0	16.8	13.00	11.00
CHJD30S21S1	800 - 1200	14	FC/MC/PC/UC32	1000	29.0	21.2	13.00	11.00
	800 - 1200	17,21	FC/MC/PC/UC35	1000	29.0	21.2	13.00	11.00
	800 - 1200	14	FC/MC/PC/UC37	1000	29.0	21.2	13.00	11.00
	800 - 1200	17,21	FC/MC/PC/UC43	1000	29.0	21.2	13.00	11.00
	800 - 1200	17	HC36	1000	29.0	21.2	13.00	11.00
	800 - 1200	21	HC42	1000	29.0	21.2	13.00	11.00
	800 - 1200	-	HD36	1000	29.0	21.2	13.00	11.00
	800 - 1200	19	MH24S	1000	29.0	21.2	13.00	11.00
CHJD36S21S1	1000 - 1400	14	FC/MC/PC/UC37	1200	35.0	25.6	13.00	11.00
	1000 - 1400	17,21	FC/MC/PC/UC43	1200	35.0	25.6	13.00	11.00
	1000 - 1400	21,24	FC/MC/PC/UC48	1200	35.0	25.6	13.00	11.00
	1000 - 1400	21,24	FC/MC/PC/UC60	1200	35.0	25.6	13.00	11.00
	1000 - 1400	21	HC42	1200	35.0	25.6	13.00	11.00
	1000 - 1400	24	HC60	1200	35.0	25.6	13.00	11.00
	1000 - 1400	-	HD48	1200	35.0	25.6	13.00	11.00
	1000 - 1400	-	HD60	1200	35.0	25.6	13.00	11.00
CHJD42S21S1	1200 - 1600	21,24	FC/MC/PC/UC48	1400	40.0	28.8	13.00	11.00
	1200 - 1600	21,24	FC/MC/PC/UC60	1400	40.0	28.8	13.00	11.00
	1200 - 1600	24	HC60	1400	40.0	28.8	13.00	11.00
	1200 - 1600	-	HD60	1400	40.0	28.8	13.00	11.00
CHJD48S21S1	1400 - 1800	21,24	FC/MC/PC/UC60	1600	45.0	33.2	13.00	11.00
	1400 - 1800	24	FC/MC62	1600	45.0	33.2	13.00	11.00
	1400 - 1800	24	HC60	1600	45.0	33.2	13.00	11.00
	1400 - 1800	-	HD60	1600	45.0	33.2	13.00	11.00
CHJD60S21S1	1600 - 2000	24	FC/MC62	1800	55.0	40.0	13.00	11.00

1. Requires a 2FD06700224 Blower Time Delay unless a standard furnace is equipped with one.

** Refer to Quick Selection Chart for specific furnace match-up.

COOLING CAPACITY - CHJD18S21S1 With Variable Speed Furnaces

VARIABLE SPEED FURNACE MODEL	COIL MODEL ¹	W	COOLING				
			RATED CFM	Net MBH		SEER	EER
				TOTAL	SENS.		
13 SEER HP WITH VARIABLE SPEED FURNACES²							
(F,L)C8V*A12	FC/MC/PC/UC18A	14	600	18.0	13.4	14.00	12.00
FC9V*A12	FC/MC/PC/UC18A	14	600	18.0	13.3	14.00	12.00
FC9(C,V)*B12	FC/MC/PC/UC18B	17	600	18.0	13.4	14.00	12.00
(F,L)C8V*A12	FC/MC/PC/UC24A	14	600	18.0	13.4	14.00	12.00
FC9V*A12	FC/MC/PC/UC24A	14	600	18.0	13.3	14.00	12.00
FC9(C,V)*B12	FC/MC/PC/UC24B	17	600	18.0	13.4	14.00	12.00
(F,L)C8V*A12	FC/MC/PC/UC30A	14	600	18.0	13.4	14.00	12.00
FC9V*A12	FC/MC/PC/UC30A	14	600	18.0	13.3	14.00	12.00
FC9(C,V)*B12	FC/MC/PC/UC30B	17	600	18.0	13.4	14.00	12.00
(F,L)C8V*A12	HC18	14	600	18.0	13.4	14.00	12.00
FC9V*A12	HC18	14	600	18.0	13.3	14.00	12.00
C*(8,L)C*A12	FC/MC/PC18A	14	620	18.0	13.3	14.50	12.00
C*(8,L)C*B12	FC/MC/PC18B	17	580	18.0	13.0	14.50	12.10
C*9C*B12	FC/MC/PC18B	17	610	18.0	13.1	14.50	12.20
C*(8,L)C*A12	FC/MC/PC24A	14	640	18.0	13.5	14.80	12.20
C*(8,L)C*B12	FC/MC/PC24B	17	575	18.0	13.0	15.00	12.40
C*9C*B12	FC/MC/PC24B	17	610	18.0	13.5	14.90	12.30
C*(8,L)C*A12	FC/MC/PC30A	14	640	18.0	13.5	14.80	12.20
C*(8,L)C*B12	FC/MC/PC30B	17	575	18.0	13.0	15.00	12.40
C*9C*B12	FC/MC/PC30B	17	610	18.0	13.5	14.90	12.30
C*(8,L)C*A12	HC18	14	620	18.0	13.2	14.50	12.10
C*(8,L)C*A12	HD24	14	640	18.0	13.3	14.90	12.40
C*(8,L)C*B12	HD24	17	575	18.0	13.0	15.00	12.30
C*9C*B12	HD24	17	610	18.0	13.3	15.00	12.50
C*(8,L)C*A12	UC18A	14	620	18.0	13.2	14.80	12.20
C*(8,L)C*B12	UC18B	17	580	18.0	13.0	14.60	12.20
C*9C*B12	UC18B	17	610	18.0	13.2	14.80	12.30
C*(8,L)C*A12	UC24A	14	640	18.0	13.6	14.90	12.20
C*(8,L)C*B12	UC24B	17	575	18.0	13.0	15.10	12.60
C*9C*B12	UC24B	17	610	18.0	13.6	15.10	12.30
C*(8,L)C*A12	UC30A	14	640	18.0	13.6	14.60	12.20
C*(8,L)C*B12	UC30B	17	575	18.0	13.0	15.10	12.60
C*9C*B12	UC30B	17	610	18.0	13.6	14.80	12.30
G*9V*A12	FC/MC/PC18A	14	625	18.0	13.3	14.10	11.80
G*9V*B12	FC/MC/PC18B	17	610	18.0	13.1	14.50	12.20
G*9V*A12	FC/MC/PC24A	14	625	18.0	13.2	14.50	12.10
G*9V*B12	FC/MC/PC24B	17	610	18.0	13.5	14.90	12.30
G*9V*A12	FC/MC/PC30A	14	625	18.0	13.2	14.50	12.10
G*9V*B12	FC/MC/PC30B	17	610	18.0	13.5	14.90	12.30
G*9V*A12	HC18	14	625	18.0	13.3	14.10	11.80
G*9V*A12	HD24	14	625	18.0	13.2	14.30	12.20
G*9V*B12	HD24	17	610	18.0	13.3	15.00	12.50
G*9V*A12	UC18A	14	625	18.0	13.2	14.30	11.90
G*9V*B12	UC18B	17	610	18.0	13.2	14.80	12.30
G*9V*A12	UC24A	14	625	18.0	13.3	14.60	12.20
G*9V*B12	UC24B	17	610	18.0	13.6	15.10	12.30
G*9V*A12	UC30A	14	625	18.0	13.3	14.60	12.20
G*9V*B12	UC30B	17	610	18.0	13.6	14.80	12.30

1. MC coils available with a factory installed horizontal drain pan. See price pages for specific model number.

2. Variable speed furnaces have B.O.D (Blower on Delay) standard.

COOLING CAPACITY - CHJD24S21S1 With Variable Speed Furnaces

VARIABLE SPEED FURNACE MODEL	COIL MODEL ¹	W	COOLING				
			RATED CFM	Net MBH		SEER	EER
				TOTAL	SENS.		
13 SEER HP WITH VARIABLE SPEED FURNACES²							
(F,L)C8V*A12	FC/MC/PC/UC24A	14	800	23.0	17.3	14.00	12.00
FC9V*A12	FC/MC/PC/UC24A	14	800	23.0	17.3	14.00	12.00
FC9(C,V)*B12	FC/MC/PC/UC24B	17	800	23.0	17.3	14.00	12.00
(F,L)C8V*A12	FC/MC/PC/UC30A	14	800	23.0	17.3	14.00	12.00
FC9V*A12	FC/MC/PC/UC30A	14	800	23.0	17.3	14.00	12.00
FC9(C,V)*B12	FC/MC/PC/UC30B	17	800	23.0	17.3	14.00	12.00
(F,L)C8V*A12	FC/MC/PC/UC32A	14	800	23.0	17.3	14.00	12.00
FC9V*A12	FC/MC/PC/UC32A	14	800	23.0	17.3	14.00	12.00
FC9(C,V)*B12	FC/MC/PC/UC35B	17	800	23.0	17.3	14.00	12.00
(F,L)C8V*A12	HC30	14	800	23.0	17.3	14.00	12.00
FC9V*A12	HC30	14	800	23.0	17.3	14.00	12.00
FC9(C,V)*B12	HC36	17	800	23.0	17.3	14.00	12.00
C*(8,L)C*A12	FC/MC/PC24A	14	805	23.4	17.1	13.60	12.20
C*(8,L)C*B12	FC/MC/PC24B	17	815	23.4	17.1	13.80	12.30
C*9C*B12	FC/MC/PC24B	17	790	23.4	17.1	13.60	12.10
C*(8,L)C*A12	FC/MC/PC30A	14	805	23.4	17.1	13.60	12.20
C*(8,L)C*B12	FC/MC/PC30B	17	815	23.4	17.1	13.80	12.30
C*9C*B12	FC/MC/PC30B	17	790	23.4	17.1	13.60	12.10
C*(8,L)C*A12	FC/MC/PC32A	14	775	23.6	17.0	14.30	12.10
C*(8,L)C*B12	FC/MC/PC35B	17	760	23.6	17.1	14.70	12.30
C*9C*B12	FC/MC/PC35B	17	815	23.4	17.4	14.20	11.90
C*(8,L)C*A12	FC/MC/PC36A	14	805	23.4	17.2	14.60	12.10
C*(8,L)C*B12	FC/MC/PC36B	17	765	23.6	17.3	14.90	12.40
C*9C*B12	FC/MC/PC36B	17	815	23.4	17.2	14.70	12.20
C*(8,L)C*A12	FC/MC/PC37A	14	805	23.8	17.6	14.50	12.10
C*(8,L)C*B12	FC/MC/PC43B	17	760	23.8	17.2	15.00	12.40
C*9C*B12	FC/MC/PC43B	17	800	24.0	17.6	14.70	12.30
C*(8,L)C*A12	HC30	14	775	23.2	16.7	13.60	12.00
C*(8,L)C*B12	HC36	17	760	23.6	16.9	14.00	12.30
C*9C*B12	HC36	17	815	23.4	17.4	14.20	11.90
C*(8,L)C*A12	HD36	14	805	23.0	16.4	14.10	12.00
C*(8,L)C*B12	HD36	17	760	23.0	16.0	13.70	12.10
C*(8,L)C*C16	HD36	21	855	23.4	17.2	13.90	12.30
C*(8,L)C*C20	HD36	21	750	23.0	16.1	14.00	12.40
C*9C*B12	HD36	17	815	23.2	16.4	14.10	12.10
C*9C*C16	HD36	21	785	23.2	16.3	13.90	12.30
C*9C*C20	HD36	21	760	23.0	16.1	13.90	12.30
C*(8,L)C*A12	UC24A	14	805	23.6	17.2	13.70	12.30
C*(8,L)C*B12	UC24B	17	815	23.8	17.3	13.90	12.40
C*9C*B12	UC24B	17	790	23.6	17.2	13.70	12.30
C*(8,L)C*A12	UC30A	14	805	23.6	17.2	13.80	12.20
C*(8,L)C*B12	UC30B	17	815	23.6	17.2	14.00	12.40
C*9C*B12	UC30B	17	790	23.6	17.2	13.80	12.20
C*(8,L)C*A12	UC36A	14	805	23.4	17.2	13.90	12.20
C*(8,L)C*B12	UC36B	17	765	23.6	17.3	14.20	12.40
C*9C*B12	UC36B	17	815	23.4	17.2	13.90	12.20
G*9V*A12	FC/MC/PC24A	14	800	23.2	16.9	13.40	11.90
G*9V*B12	FC/MC/PC24B	17	790	23.4	17.1	13.60	12.10
G*9V*A12	FC/MC/PC30A	14	800	23.2	16.9	13.40	11.90
G*9V*B12	FC/MC/PC30B	17	790	23.4	17.1	13.60	12.10
G*9V*A12	FC/MC/PC32A	14	800	23.2	17.0	13.70	11.50

For Notes See Page 10.

COOLING CAPACITY - CHJD24S21S1 With Variable Speed Furnaces (Continued)

VARIABLE SPEED FURNACE MODEL	COIL MODEL ¹	W	COOLING				
			RATED CFM	Net MBH		SEER	EER
				TOTAL	SENS.		
13 SEER HP WITH VARIABLE SPEED FURNACES²							
G*9V*B12	FC/MC/PC35B	17	815	23.4	17.4	14.20	11.90
G*9V*A12	FC/MC/PC36A	14	800	23.2	17.0	14.10	11.90
G*9V*B12	FC/MC/PC36B	17	815	23.4	17.2	14.70	12.20
G*9V*A12	FC/MC/PC37A	14	800	23.8	17.5	14.10	11.90
G*9V*B12	FC/MC/PC43B	17	800	24.0	17.6	14.70	12.30
G*9V*A12	HC30	14	800	23.2	16.9	14.10	11.90
G*9V*B12	HC36	17	815	23.4	17.4	14.20	11.90
G*9V*A12	HD36	14	800	23.0	16.3	13.80	11.80
G*9V*B12	HD36	17	815	23.2	16.4	14.10	12.10
G*9V*C16	HD36	21	785	23.2	16.3	13.90	12.30
G*9V*C20	HD36	21	760	23.0	16.1	13.90	12.30
G*9V*A12	UC24A	14	800	23.2	16.9	13.50	11.90
G*9V*B12	UC24B	17	790	23.6	17.2	13.70	12.30
G*9V*A12	UC30A	14	800	23.2	16.9	13.50	11.90
G*9V*B12	UC30B	17	790	23.6	17.2	13.80	12.20
G*9V*A12	UC36A	14	800	23.4	17.0	13.40	11.90
G*9V*B12	UC36B	17	815	23.4	17.2	13.90	12.20

1. MC coils available with a factory installed horizontal drain pan. See price pages for specific model number.
2. Variable speed furnaces have B.O.D (Blower on Delay) standard.

COOLING CAPACITY - CHJD30S21S1 With Variable Speed Furnaces

VARIABLE SPEED FURNACE MODEL	COIL MODEL ¹	W	COOLING				
			RATED CFM	Net MBH		SEER	EER
				TOTAL	SENS.		
13 SEER HP WITH VARIABLE SPEED FURNACES²							
(F,L)C8V*A12	FC/MC/PC/UC32A	14	1000	29.0	21.6	14.00	12.00
FC9V*A12	FC/MC/PC/UC32A	14	1000	29.0	21.6	14.00	12.00
(F,L)C8V*B16	FC/MC/PC/UC35B	17	1000	29.0	22.0	14.00	12.00
(F,L)C8V*C16	FC/MC/PC/UC35C	21	1000	29.0	22.0	14.00	12.00
(F,L)C8V*C20	FC/MC/PC/UC35C	21	1120	29.0	21.6	14.00	12.00
FC9(C,V)*B12	FC/MC/PC/UC35B	17	1000	29.0	21.6	14.00	12.00
FC9(C,V)*C16	FC/MC/PC/UC35C	21	1010	29.0	21.8	14.00	12.00
(F,L)C8V*A12	FC/MC/PC/UC37A	14	1000	29.0	21.6	14.00	12.00
FC9V*A12	FC/MC/PC/UC37A	14	1000	29.0	21.6	14.00	12.00
(F,L)C8V*B16	FC/MC/PC/UC43B	17	1000	29.0	22.0	14.00	12.00
(F,L)C8V*C16	FC/MC/PC/UC43C	21	1000	29.0	22.0	14.00	12.00
(F,L)C8V*C20	FC/MC/PC/UC43C	21	1120	29.0	21.6	14.00	12.00
FC9(C,V)*B12	FC/MC/PC/UC43B	17	1000	29.0	21.6	14.00	12.00
FC9(C,V)*C16	FC/MC/PC/UC43C	21	1010	29.0	21.8	14.00	12.00
(F,L)C8V*B16	HC36	17	1000	29.0	22.0	14.00	12.00
FC9(C,V)*B12	HC36	17	1000	29.0	21.6	14.00	12.00
(F,L)C8V*C16	HC42	21	1000	29.0	22.0	14.00	12.00
(F,L)C8V*C20	HC42	21	1120	29.0	21.6	14.00	12.00
FC9(C,V)*C16	HC42	21	1010	29.0	21.8	14.00	12.00
C*(8,L)C*A12	FC/MC/PC32A	14	1045	29.0	22.0	13.20	11.10
C*(8,L)C*B12	FC/MC/PC35B	17	995	29.4	22.2	14.10	11.80
C*9C*B12	FC/MC/PC35B	17	1045	29.2	22.2	13.60	11.40
C*(8,L)C*C16	FC/MC/PC35C	21	1025	29.4	22.2	14.30	12.00
C*(8,L)C*C20	FC/MC/PC35C	21	1080	29.6	22.8	14.30	12.00
C*9C*C16	FC/MC/PC35C	21	1005	29.4	22.2	14.20	11.90
C*9C*C20	FC/MC/PC35C	21	985	29.4	22.2	14.30	12.00
C*(8,L)C*A12	FC/MC/PC36A	14	1000	28.6	21.4	13.60	11.50
C*(8,L)C*B12	FC/MC/PC36B	17	985	28.8	21.6	13.90	11.70
C*9C*B12	FC/MC/PC36B	17	985	28.6	21.6	13.90	11.60

For Notes See Page 11.

COOLING CAPACITY - CHJD30S21S1 With Variable Speed Furnaces (Continued)

VARIABLE SPEED FURNACE MODEL	COIL MODEL ¹	W	COOLING				
			RATED CFM	Net MBH		SEER	EER
				TOTAL	SENS.		
13 SEER HP WITH VARIABLE SPEED FURNACES²							
C*(8,L)C*C16	FC/MC/PC36C	21	1020	28.8	21.8	14.10	11.80
C*(8,L)C*C20	FC/MC/PC36C	21	1055	28.8	21.8	14.20	11.90
C*9C*C16	FC/MC/PC36C	21	1005	28.8	21.8	14.10	11.80
C*9C*C20	FC/MC/PC36C	21	1045	28.8	21.8	14.00	11.70
C*(8,L)C*A12	FC/MC/PC37A	14	980	29.2	22.0	13.70	11.50
C*(8,L)C*B12	FC/MC/PC43B	17	990	29.4	22.2	14.20	11.90
C*9C*B12	FC/MC/PC43B	17	1035	29.4	22.2	13.80	11.60
C*(8,L)C*C16	FC/MC/PC43C	21	990	29.6	22.4	14.60	12.20
C*(8,L)C*C20	FC/MC/PC43C	21	1000	29.8	22.6	14.60	12.30
C*9C*C16	FC/MC/PC43C	21	1030	29.4	22.2	14.10	11.90
C*9C*C20	FC/MC/PC43C	21	995	29.6	22.6	14.50	12.10
C*(8,L)C*B12	HC36	17	995	29.0	21.8	13.90	11.70
C*9C*B12	HC36	17	1045	29.2	22.2	13.60	11.40
C*(8,L)C*C16	HC42	21	990	29.6	22.4	14.60	12.20
C*(8,L)C*C20	HC42	21	1000	29.6	22.4	14.60	12.30
C*9C*C16	HC42	21	1030	29.4	22.2	14.10	11.90
C*9C*C20	HC42	21	995	29.6	22.4	14.40	12.10
C*(8,L)C*A12	HD36	14	1000	28.2	20.8	13.40	11.30
C*(8,L)C*B12	HD36	17	985	28.4	20.8	13.70	11.60
C*(8,L)C*C16	HD36	21	1020	28.4	20.8	13.80	11.70
C*(8,L)C*C20	HD36	21	1055	28.8	21.4	14.00	11.80
C*9C*B12	HD36	17	985	28.4	20.8	13.60	11.50
C*9C*C16	HD36	21	1005	28.4	20.8	13.80	11.70
C*9C*C20	HD36	21	1045	28.4	20.8	13.70	11.60
C*(8,L)C*A12	UC36A	14	1000	28.6	21.4	13.60	11.50
C*(8,L)C*B12	UC36B	17	985	28.8	21.6	13.90	11.70
C*9C*B12	UC36B	17	985	28.8	21.6	13.80	11.70
C*(8,L)C*C16	UC36C	21	1020	28.6	21.6	14.10	11.80
C*(8,L)C*C20	UC36C	21	1055	28.6	21.8	14.10	11.80
C*9C*C16	UC36C	21	1000	28.6	21.6	14.10	11.80
C*9C*C20	UC36C	21	1045	28.6	21.6	13.90	11.60
G*9V*A12	FC/MC/PC32A	14	1000	29.0	21.8	13.70	11.50
G*9V*B12	FC/MC/PC35B	17	1045	29.2	22.2	13.60	11.40
G*9V*C16	FC/MC/PC35C	21	1005	29.4	22.2	14.20	11.90
G*9V*C20	FC/MC/PC35C	21	985	29.4	22.2	14.30	12.00
G*9V*A12	FC/MC/PC36A	14	1000	28.6	21.4	13.60	11.40
G*9V*B12	FC/MC/PC36B	17	985	28.6	21.6	13.90	11.60
G*9V*C16	FC/MC/PC36C	21	1005	28.8	21.8	14.10	11.80
G*9V*C20	FC/MC/PC36C	21	1045	28.8	21.8	14.00	11.70
G*9V*A12	FC/MC/PC37A	14	1000	29.4	22.2	13.70	11.50
G*9V*B12	FC/MC/PC43B	17	1035	29.4	22.2	13.80	11.60
G*9V*C16	FC/MC/PC43C	21	1030	29.4	22.2	14.10	11.90
G*9V*C20	FC/MC/PC43C	21	995	29.6	22.6	14.50	12.10
G*9V*B12	HC36	17	1045	29.2	22.2	13.60	11.40
G*9V*C16	HC42	21	1030	29.4	22.2	14.10	11.90
G*9V*C20	HC42	21	995	29.6	22.4	14.40	12.10
G*9V*A12	HD36	14	1000	28.2	20.6	13.30	11.30
G*9V*B12	HD36	17	985	28.4	20.8	13.60	11.50
G*9V*C16	HD36	21	1005	28.4	20.8	13.80	11.70
G*9V*C20	HD36	21	1045	28.4	20.8	13.70	11.60
G*9V*A12	UC36A	14	1000	28.6	21.4	13.60	11.50
G*9V*B12	UC36B	17	985	28.8	21.6	13.80	11.70
G*9V*C16	UC36C	21	1000	28.6	21.6	14.10	11.80
G*9V*C20	UC36C	21	1045	28.6	21.6	13.90	11.60

1. MC coils available with a factory installed horizontal drain pan. See price pages for specific model number.

2. Variable speed furnaces have B.O.D (Blower on Delay) standard.

COOLING CAPACITY - CHJD36S21S1 With Variable Speed Furnaces

VARIABLE SPEED FURNACE MODEL	COIL MODEL ¹	W	COOLING				
			RATED CFM	Net MBH		SEER	EER
				TOTAL	SENS.		
13 SEER HP WITH VARIABLE SPEED FURNACES²							
(F,L)C8V*A12	FC/MC/PC/UC37A	14	1200	35.0	26.0	13.55	11.00
FC9V*A12	FC/MC/PC/UC37A	14	1200	35.0	25.8	13.25	11.00
(F,L)C8V*B16	FC/MC/PC/UC43B	17	1200	35.0	26.2	14.00	12.00
(F,L)C8V*C16	FC/MC/PC/UC43C	21	1200	35.0	26.2	14.00	12.00
(F,L)C8V*C20	FC/MC/PC/UC43C	21	1200	35.0	26.0	13.85	12.00
FC9(C,V)*B12	FC/MC/PC/UC43B	17	1200	35.0	26.0	13.70	12.00
FC9(C,V)*C16	FC/MC/PC/UC43C	21	1175	35.0	26.2	14.00	12.00
FC9(C,V)*C20	FC/MC/PC/UC43C	21	1200	35.0	26.2	14.00	12.00
(F,L)C8V*C16	FC/MC/PC/UC48C	21	1200	35.0	26.4	14.00	12.00
(F,L)C8V*C20	FC/MC/PC/UC48C	21	1200	35.0	26.0	13.90	12.00
FC9(C,V)*C16	FC/MC/PC/UC48C	21	1175	35.0	26.2	14.00	12.00
FC9(C,V)*C20	FC/MC/PC/UC48C	21	1200	35.0	26.2	14.00	12.00
FC9(C,V)*D20	FC/MC/PC/UC48D	24	1200	35.0	26.2	14.00	12.00
(F,L)C8V*C16	HC42	21	1200	35.0	26.2	14.00	12.00
(F,L)C8V*C20	HC42	21	1200	35.0	26.0	13.90	12.00
FC9(C,V)*C16	HC42	21	1175	35.0	26.2	14.00	12.00
FC9(C,V)*C20	HC42	21	1200	35.0	26.2	14.00	12.00
C*(8,L)C*A12	FC/MC/PC37A	14	980	34.6	24.0	13.70	11.60
C*(8,L)C*B12	FC/MC/PC43B	17	1210	35.6	26.4	13.70	11.40
C*9C*B12	FC/MC/PC43B	17	1200	35.6	26.4	13.70	11.40
C*(8,L)C*C16	FC/MC/PC43C	21	1205	36.0	26.8	14.40	12.00
C*(8,L)C*C20	FC/MC/PC43C	21	1190	36.0	26.6	14.40	12.10
C*9C*C16	FC/MC/PC43C	21	1240	35.8	26.6	13.90	11.60
C*9C*C20	FC/MC/PC43C	21	1200	35.8	26.8	14.30	11.80
C*(8,L)C*C16	FC/MC/PC48C	21	1210	35.8	27.0	14.00	12.00
C*(8,L)C*C20	FC/MC/PC48C	21	1155	35.8	27.0	14.20	12.10
C*9C*C16	FC/MC/PC48C	21	1195	35.6	27.0	13.80	11.80
C*9C*C20	FC/MC/PC48C	21	1330	36.0	28.0	13.80	11.60
C*(8,L)C*C16	HC42	21	1205	35.8	26.6	14.20	11.90
C*(8,L)C*C20	HC42	21	1190	35.8	26.8	14.40	12.00
C*9C*C16	HC42	21	1240	35.4	26.6	13.70	11.50
C*9C*C20	HC42	21	1200	35.6	26.6	14.10	11.80
C*(8,L)C*B12	HD48	17	1210	35.6	26.2	13.00	11.60
C*(8,L)C*C16	HD48	21	1210	36.0	26.6	14.50	12.00
C*(8,L)C*C20	HD48	21	1155	36.0	26.6	14.70	12.20
C*9C*B12	HD48	17	1150	35.6	26.2	13.00	11.50
C*9C*C16	HD48	21	1195	35.8	26.6	14.30	11.90
C*9C*C20	HD48	21	1330	36.0	27.4	13.30	11.60
C*(8,L)C*C16	UC48C	21	1210	36.0	27.0	14.30	12.10
C*(8,L)C*C20	UC48C	21	1155	36.0	27.0	14.50	12.30
C*9C*C16	UC48C	21	1195	36.0	27.0	14.10	11.90
C*9C*C20	UC48C	21	1330	36.0	28.0	13.70	11.60
G*9V*A12	FC/MC/PC37A	14	1100	35.2	25.2	13.40	11.40
G*9V*B12	FC/MC/PC43B	17	1200	35.6	26.4	13.70	11.40
G*9V*C16	FC/MC/PC43C	21	1240	35.8	26.6	13.90	11.60
G*9V*C20	FC/MC/PC43C	21	1200	35.8	26.8	14.30	11.80
G*9V*C16	FC/MC/PC48C	21	1195	35.6	27.0	13.80	11.80
G*9V*C20	FC/MC/PC48C	21	1330	36.0	28.0	13.80	11.60
G*9V*C16	HC42	21	1240	35.4	26.6	13.70	11.50
G*9V*C20	HC42	21	1200	35.6	26.6	14.10	11.80
G*9V*B12	HD48	17	1150	35.6	26.2	13.00	11.50
G*9V*C16	HD48	21	1195	35.8	26.6	14.30	11.90
G*9V*C20	HD48	21	1330	36.0	27.4	13.30	11.60
G*9V*C16	UC48C	21	1195	36.0	27.0	14.10	11.90
G*9V*C20	UC48C	21	1330	36.0	28.0	13.70	11.60

1. MC coils available with a factory installed horizontal drain pan. See price pages for specific model number.

2. Variable speed furnaces have B.O.D (Blower on Delay) standard.

COOLING CAPACITY - CHJD42S21S1 With Variable Speed Furnaces

VARIABLE SPEED FURNACE MODEL	COIL MODEL ¹	W	COOLING				
			RATED CFM	Net MBH		SEER	EER
				TOTAL	SENS.		
13 SEER HP WITH VARIABLE SPEED FURNACES²							
(F,L)C8V*C16	FC/MC/PC/UC48C	21	1400	40.0	29.2	13.45	11.00
(F,L)C8V*C20	FC/MC/PC/UC48C	21	1400	41.0	29.2	13.55	11.00
FC9(C,V)*C16	FC/MC/PC/UC48C	21	1415	40.0	29.0	13.25	11.00
FC9(C,V)*C20	FC/MC/PC/UC48C	21	1400	40.0	29.2	13.45	11.00
FC9(C,V)*D20	FC/MC/PC/UC48D	24	1400	40.0	29.0	13.35	11.00
(F,L)C8V*C16	FC/PC/UC60C	21	1400	41.0	29.2	13.45	11.00
(F,L)C8V*C20	FC/PC/UC60C	21	1400	41.0	29.2	13.60	11.00
FC9(C,V)*C16	FC/PC/UC60C	21	1415	40.0	29.0	13.25	11.00
FC9(C,V)*C20	FC/PC/UC60C	21	1400	41.0	29.2	13.45	11.00
FC9(C,V)*D20	FC/MC/PC/UC60D	24	1400	40.0	29.0	13.40	11.00
C*(8,L)C*C16	FC/MC/PC48C	21	1435	40.5	31.0	13.80	11.60
C*(8,L)C*C20	FC/MC/PC48C	21	1410	41.0	31.2	13.90	11.70
C*9C*C16	FC/MC/PC48C	21	1395	40.5	31.0	13.60	11.50
C*9C*C20	FC/MC/PC48C	21	1430	40.5	31.0	13.50	11.40
C*9C*D20	FC/MC/PC48D	24	1450	40.5	31.0	13.70	11.60
C*9C*D20	FC/MC/PC60D	24	1445	40.0	30.8	13.50	11.40
C*(8,L)C*C16	FC/PC60C	21	1420	40.0	30.8	13.60	11.50
C*(8,L)C*C20	FC/PC60C	21	1410	40.0	31.0	13.80	11.70
C*9C*C16	FC/PC60C	21	1445	39.5	30.6	13.10	11.10
C*9C*C20	FC/PC60C	21	1445	39.5	30.6	13.40	11.30
C*(8,L)C*B12	HD48	17	1350	39.0	28.8	13.30	11.30
C*(8,L)C*C16	HD48	21	1435	40.0	30.0	13.80	11.70
C*(8,L)C*C20	HD48	21	1410	40.0	30.0	13.90	11.80
C*9C*B12	HD48	17	1150	37.2	26.6	13.50	11.30
C*9C*C16	HD48	21	1395	39.5	29.8	13.60	11.60
C*9C*C20	HD48	21	1430	39.5	29.8	13.50	11.50
C*9C*D20	HD48	24	1450	40.0	30.0	13.70	11.70
C*(8,L)C*C16	UC48C	21	1435	39.5	30.4	13.50	11.40
C*(8,L)C*C20	UC48C	21	1410	39.5	30.6	13.60	11.50
C*9C*C16	UC48C	21	1395	39.5	30.4	13.30	11.30
C*9C*C20	UC48C	21	1430	39.5	30.4	13.20	11.20
C*9C*D20	UC48D	24	1450	39.5	30.4	13.40	11.30
C*(8,L)C*C16	UC60C	21	1420	39.5	30.2	13.50	11.40
C*(8,L)C*C20	UC60C	21	1410	39.5	30.4	13.70	11.60
C*9C*C16	UC60C	21	1445	39.0	30.0	13.00	11.00
C*9C*C20	UC60C	21	1445	39.0	30.0	13.20	11.20
C*9C*D20	UC60D	24	1445	39.5	30.2	13.40	11.30
G*9V*C16	FC/MC/PC48C	21	1395	40.5	31.0	13.60	11.50
G*9V*C20	FC/MC/PC48C	21	1430	40.5	31.0	13.50	11.40
G*9V*D20	FC/MC/PC48D	24	1450	40.5	31.0	13.70	11.60
G*9V*D20	FC/MC/PC60D	24	1445	40.0	30.8	13.50	11.40
G*9V*C16	FC/PC60C	21	1445	39.5	30.6	13.10	11.10
G*9V*C20	FC/PC60C	21	1445	39.5	30.6	13.40	11.30
G*9V*B12	HD48	17	1150	37.2	26.6	13.50	11.30
G*9V*C16	HD48	21	1395	39.5	29.8	13.60	11.60
G*9V*C20	HD48	21	1430	39.5	29.8	13.50	11.50
G*9V*D20	HD48	24	1450	40.0	30.0	13.70	11.70
G*9V*C16	UC48C	21	1395	39.5	30.4	13.30	11.30
G*9V*C20	UC48C	21	1430	39.5	30.4	13.20	11.20
G*9V*D20	UC48D	24	1450	39.5	30.4	13.40	11.30
G*9V*C16	UC60C	21	1445	39.0	30.0	13.00	11.00
G*9V*C20	UC60C	21	1445	39.0	30.0	13.20	11.20
G*9V*D20	UC60D	24	1445	39.5	30.2	13.40	11.30

1. MC coils available with a factory installed horizontal drain pan. See price pages for specific model number.

2. Variable speed furnaces have B.O.D (Blower on Delay) standard.

COOLING CAPACITY - CHJD48S21S1 With Variable Speed Furnaces

VARIABLE SPEED FURNACE MODEL	COIL MODEL ¹	W	COOLING				
			RATED CFM	Net MBH		SEER	EER
				TOTAL	SENS.		
13 SEER HP WITH VARIABLE SPEED FURNACES²							
(F,L)C8V*C16	FC/PC/UC60C	21	1500	45.0	33.4	13.25	11.00
(F,L)C8V*C20	FC/PC/UC60C	21	1610	45.0	33.4	13.25	11.00
FC9(C,V)*C16	FC/PC/UC60C	21	1600	45.0	33.2	13.25	11.00
FC9(C,V)*C20	FC/PC/UC60C	21	1600	45.0	33.4	13.25	11.00
FC9(C,V)*D20	FC/MC/PC/UC60D	24	1600	45.0	33.4	13.25	11.00
(F,L)C8V*C20	FC/MC62D	24	1610	45.0	33.4	13.25	11.00
FC9(C,V)*C20	FC/MC62D	24	1600	45.0	33.4	13.25	11.00
FC9(C,V)*D20	FC/MC62D	24	1600	45.0	33.4	13.25	11.00
C*9C*D20	FC/MC/PC60D	24	1615	45.5	33.2	13.20	11.30
C*9C*D20	FC/MC62D	24	1630	45.5	33.6	13.40	11.30
C*(8,L)C*C16	FC/PC60C	21	1625	45.5	33.4	13.50	11.40
C*(8,L)C*C20	FC/PC60C	21	1605	45.5	33.6	13.70	11.60
C*9C*C16	FC/PC60C	21	1590	45.5	33.4	13.20	11.20
C*9C*C20	FC/PC60C	21	1655	45.5	33.4	13.20	11.20
C*9C*D20	HC60	24	1615	45.5	33.4	13.40	11.30
C*(8,L)C*C16	HD60	21	1625	45.0	33.2	13.40	11.20
C*(8,L)C*C20	HD60	21	1605	45.0	33.4	13.70	11.40
C*9C*C16	HD60	21	1590	44.5	33.0	13.20	11.10
C*9C*C20	HD60	21	1655	44.5	33.0	13.20	11.10
C*9C*D20	HD60	24	1615	44.5	33.2	13.30	11.10
C*(8,L)C*C16	UC60C	21	1625	45.0	32.8	13.40	11.30
C*(8,L)C*C20	UC60C	21	1605	45.5	33.0	13.70	11.50
C*9C*C16	UC60C	21	1590	45.0	32.8	13.20	11.10
C*9C*C20	UC60C	21	1655	45.0	32.8	13.20	11.10
C*9C*D20	UC60D	24	1615	45.0	32.6	13.30	11.20
G*9V*D20	FC/MC/PC60D	24	1615	45.5	33.2	13.20	11.30
G*9V*D20	FC/MC62D	24	1630	45.5	33.6	13.40	11.30
G*9V*C16	FC/PC60C	21	1590	45.5	33.4	13.20	11.20
G*9V*C20	FC/PC60C	21	1655	45.5	33.4	13.20	11.20
G*9V*D20	HC60	24	1615	45.5	33.4	13.40	11.30
G*9V*C16	HD60	21	1590	44.5	33.0	13.20	11.10
G*9V*C20	HD60	21	1655	44.5	33.0	13.20	11.10
G*9V*D20	HD60	24	1615	44.5	33.2	13.30	11.10
G*9V*C16	UC60C	21	1590	45.0	32.8	13.20	11.10
G*9V*C20	UC60C	21	1655	45.0	32.8	13.20	11.10
G*9V*D20	UC60D	24	1615	45.0	32.6	13.30	11.20

1. MC coils available with a factory installed horizontal drain pan. See price pages for specific model number.

2. Variable speed furnaces have B.O.D (Blower on Delay) standard.

COOLING CAPACITY - CHJD60S21S1 With Variable Speed Furnaces

VARIABLE SPEED FURNACE MODEL	COIL MODEL ¹	W	COOLING				
			RATED CFM	Net MBH		SEER	EER
				TOTAL	SENS.		
13 SEER HP WITH VARIABLE SPEED FURNACES²							
(F,L)C8V*C20	FC/MC62D	24	1730	55.0	40.0	13.50	11.00
FC9(C,V)*C20	FC/MC62D	24	1620	54.0	40.5	13.50	11.00
FC9(C,V)*D20	FC/MC62D	24	1620	54.0	40.5	13.50	11.00
C*(8,L)C*C20	FC/MC62D	21	1615	55.0	37.4	13.70	11.50
C*9C*C20	FC/MC62D	21	1655	54.5	37.2	13.30	11.20
C*9C*D20	FC/MC62D	24	1630	54.5	37.2	13.40	11.30
G*9V*C20	FC/MC62D	21	1655	54.5	37.2	13.30	11.20
G*9V*D20	FC/MC62D	24	1630	54.5	37.2	13.40	11.30

1. MC coils available with a factory installed horizontal drain pan. See price pages for specific model number.

2. Variable speed furnaces have B.O.D (Blower on Delay) standard.

HEATING PERFORMANCE - With Air Handler

UNIT MODEL*	AIR HANDLER	COIL ¹ MODEL	ARI HEATING ²						
			47°F			17°F			HSPF
			MBH	COP	KW	MBH	COP	KW	STD
13 SEER HP WITH MA									
CHJD18S21S1	MA08B	FC/MC18B	17.0	3.26	1.54	9.0	2.18	1.23	7.70
	MA08B	FC/MC24B	17.0	3.26	1.54	9.0	2.18	1.23	7.70
	MA08B	FC/MC30B	17.0	3.26	1.54	9.0	2.18	1.23	7.70
CHJD24S21S1	MA08B	FC/MC24B	23.0	3.72	1.82	12.0	2.44	1.47	7.70
	MA08B	FC/MC30B	23.0	3.72	1.82	12.0	2.44	1.47	7.70
	MA08B	FC/MC35B	23.0	3.72	1.82	12.0	2.44	1.47	7.70
CHJD30S21S1	MA12B	FC/MC35B	29.0	3.56	2.40	15.0	2.24	1.96	7.70
	MA12B	FC/MC43B	29.0	3.56	2.40	15.0	2.24	1.96	7.70
CHJD36S21S1	MA12B	FC/MC43B	34.0	3.58	2.78	21.0	2.52	2.39	8.50
	MA14D	FC/MC48D	34.0	3.58	2.78	21.0	2.52	2.39	8.50
	MA14D	FC/MC60D	34.0	3.58	2.78	21.0	2.52	2.39	8.50
CHJD42S21S1	MA14D	FC/MC48D	42.0	3.52	3.45	25.0	2.60	2.81	8.50
	MA16C	FC/MC48C	42.0	3.52	3.45	25.0	2.60	2.81	8.50
	MA14D	FC/MC60D	42.0	3.52	3.45	25.0	2.60	2.81	8.50
	MA16C	FC60C	42.0	3.52	3.45	25.0	2.60	2.81	8.50
CHJD48S21S1	MA16C	FC60C	48.0	3.40	4.13	37.0	2.76	3.97	7.70
	MA20D	FC/MC60D	48.0	3.40	4.13	37.0	2.76	3.97	7.70
	MA20D	FC/MC62D	48.0	3.40	4.13	37.0	2.76	3.97	7.70
CHJD60S21S1	MA20D	FC/MC62D	58.0	3.46	4.91	40.0	2.36	4.90	7.70
13 SEER HP WITH MV - VARIABLE SPEED									
CHJD18S21S1	MV12B	FC/MC18B	17.0	3.44	1.43	9.0	2.30	1.10	8.00
	MV12B	FC/MC24B	17.0	3.46	1.41	9.0	2.30	1.10	8.00
	MV12B	FC/MC30B	17.0	3.46	1.41	9.0	2.30	1.10	8.00
CHJD24S21S1	MV12B	FC/MC24B	23.0	4.02	1.64	12.0	2.62	1.30	8.10
	MV12B	FC/MC30B	23.0	4.02	1.64	12.0	2.62	1.30	8.10
	MV12B	FC/MC35B	22.0	4.02	1.63	12.0	2.64	1.29	8.25
CHJD30S21S1	MV12B	FC/MC35B	29.0	3.76	2.22	14.0	2.36	1.78	7.95
	MV16C	FC/MC35C	28.0	3.76	2.21	14.0	2.36	1.77	7.95
	MV12B	FC/MC43B	29.0	3.74	2.24	14.0	2.36	1.78	7.95
	MV16C	FC/MC43C	28.0	3.78	2.20	14.0	2.36	1.77	7.95
CHJD36S21S1	MV12B	FC/MC43B	33.0	3.72	2.63	20.0	2.62	2.23	8.80
	MV16C	FC/MC43C	33.0	3.80	2.55	20.0	2.66	2.19	8.90
	MV16C	FC/MC48C	33.0	3.82	2.54	20.0	2.68	2.16	9.00
	MV16C	FC60C	33.0	3.82	2.54	20.0	2.68	2.16	9.00
	MV12D	FC/MC48D	33.0	3.82	2.54	20.0	2.68	2.16	9.00
	MV12D	FC/MC60D	33.0	3.78	2.55	20.0	2.66	2.18	8.90
CHJD42S21S1	MV16C	FC/MC48C	40.0	3.68	3.18	24.0	2.72	2.60	8.80
	MV16C	FC60C	40.0	3.68	3.18	24.0	2.72	2.60	8.80
	MV20D	FC/MC48D	40.0	3.70	3.20	24.0	2.74	2.58	8.85
	MV20D	FC/MC60D	40.0	3.70	3.20	24.0	2.74	2.58	8.85
CHJD48S21S1	MV16C	FC60C	47.5	3.44	4.04	37.2	2.78	2.92	7.80
	MV20D	FC/MC60D	48.0	3.48	3.99	37.0	2.82	3.84	8.00
	MV20D	FC/MC62D	47.5	3.50	3.98	37.0	2.82	3.84	8.10
CHJD60S21S1	MV20D	FC/MC62D	58.0	3.52	4.78	39.0	2.40	4.76	7.75

For Notes See Page 16.

HEATING PERFORMANCE - With Air Handler (Continued)

UNIT MODEL*	AIR HANDLER	COIL ¹ MODEL	ARI HEATING ²						
			47°F			17°F			HSPF
			MBH	COP	KW	MBH	COP	KW	STD
13 SEER HP WITH AV / SV / F*FV - VARIABLE SPEED									
CHJD18S21S1	AV24	—	17.0	3.46	1.40	9.0	2.32	1.08	8.00
CHJD24S21S1	AV24	—	22.0	4.04	1.62	12.0	2.64	1.28	8.40
CHJD30S21S1	AV36	—	28.0	3.80	2.18	14.0	2.38	1.76	8.00
CHJD36S21S1	AV36	—	33.0	3.74	2.61	20.0	2.62	2.23	8.80
	AV/SV48	—	33.0	3.74	2.61	20.0	2.62	2.23	8.80
CHJD42S21S1	AV/SV48	—	40.0	3.68	3.18	24.0	2.74	2.58	8.85
	AV/SV60	—	40.0	3.70	3.20	24.0	2.74	2.58	8.85
	F4FV060	—	40.0	3.70	3.20	24.0	2.74	2.58	8.85
CHJD48S21S1	AV/SV48	—	48.0	3.50	3.97	37.0	2.82	3.84	8.00
	AV/SV60	—	48.0	3.48	3.99	37.0	2.82	3.84	8.00
	F4FV060	—	48.0	3.48	3.99	37.0	2.82	3.84	8.00
13 SEER HP WITH AHP / SHP / F*FP									
CHJD18S21S1	AHP18	—	17.0	3.26	1.54	9.0	2.18	1.23	7.70
	AHP24	—	17.0	3.28	1.52	9.0	2.18	1.22	7.70
	F4FP024	—	17.0	3.26	1.54	9.0	2.18	1.23	7.70
CHJD24S21S1	AHP24	—	23.0	3.74	1.80	12.0	2.46	1.45	7.70
	AHP30	—	23.0	3.74	1.80	12.0	2.44	1.46	7.70
	F4FP030	—	23.0	3.74	1.80	12.0	2.46	1.45	7.70
CHJD30S21S1	AHP30	—	29.0	3.54	2.41	15.0	2.24	1.96	7.65
	AHP36	—	29.0	3.54	2.41	15.0	2.24	1.96	7.65
	F4FP040	—	29.0	3.54	2.41	15.0	2.24	1.96	7.65
CHJD36S21S1	AHP36	—	34.0	3.58	2.78	21.0	2.52	2.39	8.50
	AHP42	—	34.0	3.60	2.76	20.0	2.52	2.37	8.55
	AHP/SHP60	—	33.0	3.74	2.61	20.0	2.62	2.23	8.80
	F4FP045	—	34.0	3.58	2.78	21.0	2.52	2.39	8.50
	F5FP048	—	33.0	3.74	2.61	20.0	2.62	2.23	8.80
	F5FP060	—	33.0	3.74	2.61	20.0	2.62	2.23	8.80
CHJD42S21S1	AHP/SHP48	—	42.0	3.56	3.41	25.0	2.64	2.75	8.60
	AHP/SHP60	—	40.0	3.70	3.20	24.0	2.74	2.58	8.85
	F4FP045	—	42.0	3.56	3.41	25.0	2.64	2.75	8.60
	F5FP048	—	40.0	3.70	3.20	24.0	2.74	2.58	8.85
	F5FP060	—	40.0	3.70	3.20	24.0	2.74	2.58	8.85
CHJD48S21S1	AHP/SHP48	—	48.0	3.40	4.13	37.0	2.74	3.99	7.70
	AHP/SHP60	—	48.0	3.48	3.99	37.0	2.80	3.87	8.00
	F5FP060	—	48.0	3.48	3.99	37.0	2.80	3.87	8.00

1. Rated CFM same as for cooling.

2. Heating MBH based on ARI standards of 70° DB entering indoor air, 72% RH outdoor air with 25 feet of interconnecting piping and no supplemental electric heat operation.

CP equals MBH output divided by (total KW input x 3.412).

HSPF (Heating Seasonal Performance Factor) is the total heating output during a normal annual usage period for heating divided by the total electric power input during the same period.

— = Not Applicable.

HEATING PERFORMANCE - Upflow, Downflow, and Horizontal Furnaces and Coils

UNIT MODEL*	COIL ¹ MODEL	ARI HEATING ²						
		47°F			17°F			HSPF STD
		MBH	COP	KW	MBH	COP	KW	
CHJD18S21S1	FC/MC/PC/UC18	17.0	3.26	1.54	9.0	2.18	1.23	7.70
	FC/MC/PC/UC24	17.0	3.26	1.54	9.0	2.18	1.23	7.70
	FC/MC/PC/UC30	17.0	3.26	1.54	9.0	2.18	1.23	7.70
	HC18	17.0	3.26	1.54	9.0	2.18	1.23	7.70
CHJD24S21S1	FC/MC/PC/UC24	23.0	3.72	1.82	12.0	2.44	1.47	7.70
	FC/MC/PC/UC30	23.0	3.72	1.82	12.0	2.44	1.47	7.70
	FC/MC/PC/UC32	23.0	3.72	1.82	12.0	2.44	1.47	7.70
	FC/MC/PC/UC35	23.0	3.72	1.82	12.0	2.44	1.47	7.70
	HC30	23.0	3.72	1.82	12.0	2.44	1.47	7.70
	HC36	23.0	3.72	1.82	12.0	2.44	1.47	7.70
	HD24	23.0	3.72	1.82	12.0	2.44	1.47	7.70
	MH24S	23.0	3.72	1.82	12.0	2.44	1.47	7.70
MH30S	23.0	3.72	1.82	12.0	2.44	1.47	7.70	
CHJD30S21S1	FC/MC/PC/UC32	29.0	3.56	2.40	15.0	2.24	1.96	7.70
	FC/MC/PC/UC35	29.0	3.56	2.40	15.0	2.24	1.96	7.70
	FC/MC/PC/UC37	29.0	3.56	2.40	15.0	2.24	1.96	7.70
	FC/MC/PC/UC43	29.0	3.56	2.40	15.0	2.24	1.96	7.70
	HC36	29.0	3.56	2.40	15.0	2.24	1.96	7.70
	HC42	29.0	3.56	2.40	15.0	2.24	1.96	7.70
	HD36	29.0	3.56	2.40	15.0	2.24	1.96	7.70
	MH24S	29.0	3.56	2.40	15.0	2.24	1.96	7.70
MH30S	29.0	3.56	2.40	15.0	2.24	1.96	7.70	
CHJD36S21S1	FC/MC/PC/UC37	34.0	3.58	2.78	21.0	2.52	2.39	8.50
	FC/MC/PC/UC43	34.0	3.58	2.78	21.0	2.52	2.39	8.50
	FC/MC/PC/UC48	34.0	3.58	2.78	21.0	2.52	2.39	8.50
	FC/MC/PC/UC60	34.0	3.58	2.78	21.0	2.52	2.39	8.50
	HC42	34.0	3.58	2.78	21.0	2.52	2.39	8.50
	HC60	34.0	3.58	2.78	21.0	2.52	2.39	8.50
	HD48	34.0	3.58	2.78	21.0	2.52	2.39	8.50
	HD60	34.0	3.58	2.78	21.0	2.52	2.39	8.50
CHJD42S21S1	FC/MC/PC/UC48	42.0	3.52	3.45	25.0	2.60	2.81	8.50
	FC/MC/PC/UC60	42.0	3.52	3.45	25.0	2.60	2.81	8.50
	HC60	42.0	3.52	3.45	25.0	2.60	2.81	8.50
	HD60	42.0	3.52	3.45	25.0	2.60	2.81	8.50
CHJD48S21S1	FC/MC/PC/UC60	48.0	3.40	4.13	37.0	2.76	3.97	7.70
	FC/MC62	48.0	3.40	4.13	37.0	2.76	3.97	7.70
	HC60	48.0	3.40	4.13	37.0	2.76	3.97	7.70
	HD60	48.0	3.40	4.13	37.0	2.76	3.97	7.70
CHJD60S21S1	FC/MC62	58.0	3.46	4.91	40.0	2.36	4.90	7.70

1. Rated CFM same as for cooling.

2. Heating MBH based on ARI standards of 70° DB entering indoor air, 72% RH outdoor air with 25 feet of interconnecting piping and no supplemental electric heat operation.

CP equals MBH output divided by (total KW input x 3.412).

HSPF (Heating Seasonal Performance Factor) is the total heating output during a normal annual usage period for heating divided by the total electric power input during the same period.

— = Not Applicable.

HEATING CAPACITY - CHJD18S21S1 With Variable Speed Furnaces

VARIABLE SPEED FURNACE	COIL ¹ MODEL	ARI HEATING ²						
		47°F			17°F			HSPF
		MBH	COP	KW	MBH	COP	KW	STD
13 SEER HP WITH VARIABLE SPEED FURNACES³								
(F,L)C8V*A12	FC/MC/PC/UC18A	17.0	3.46	1.41	9.0	2.32	1.09	8.00
FC9V*A12	FC/MC/PC/UC18A	17.0	3.42	1.43	9.0	2.28	1.13	8.00
FC9(C,V)*B12	FC/MC/PC/UC18B	17.0	3.46	1.41	9.0	2.30	1.10	8.00
(F,L)C8V*A12	FC/MC/PC/UC24A	17.0	3.46	1.41	9.0	2.32	1.09	8.00
FC9V*A12	FC/MC/PC/UC24A	17.0	3.42	1.43	9.0	2.28	1.13	8.00
FC9(C,V)*B12	FC/MC/PC/UC24B	17.0	3.46	1.41	9.0	2.30	1.10	8.00
(F,L)C8V*A12	FC/MC/PC/UC30A	17.0	3.46	1.41	9.0	2.32	1.09	8.00
FC9V*A12	FC/MC/PC/UC30A	17.0	3.42	1.43	9.0	2.28	1.13	8.00
FC9(C,V)*B12	FC/MC/PC/UC30B	17.0	3.46	1.41	9.0	2.30	1.10	8.00
(F,L)C8V*A12	HC18	17.0	3.46	1.41	9.0	2.32	1.09	8.00
FC9V*A12	HC18	17.0	3.42	1.43	9.0	2.28	1.13	8.00
C*(8,L)C*A12	FC/MC/PC18A	16.7	3.48	1.41	8.6	2.30	1.10	8.00
C*(8,L)C*B12	FC/MC/PC18B	16.6	3.44	1.41	8.6	2.32	1.09	8.00
C*9C*B12	FC/MC/PC18B	16.6	3.48	1.40	8.6	2.32	1.09	8.00
C*(8,L)C*A12	FC/MC/PC24A	17.1	3.60	1.39	9.2	2.46	1.10	8.20
C*(8,L)C*B12	FC/MC/PC24B	16.8	3.58	1.38	9.0	2.46	1.07	8.20
C*9C*B12	FC/MC/PC24B	17.1	3.62	1.38	9.2	2.46	1.10	8.20
C*(8,L)C*A12	FC/MC/PC30A	17.1	3.60	1.39	9.2	2.46	1.10	8.20
C*(8,L)C*B12	FC/MC/PC30B	16.8	3.58	1.38	9.0	2.46	1.07	8.20
C*9C*B12	FC/MC/PC30B	17.1	3.62	1.38	9.2	2.46	1.10	8.20
C*(8,L)C*A12	HC18	16.7	3.48	1.41	8.6	2.30	1.10	8.00
C*(8,L)C*A12	HD24	16.9	3.52	1.41	9.0	2.38	1.11	8.10
C*(8,L)C*B12	HD24	16.5	3.48	1.39	8.6	2.34	1.08	8.00
C*9C*B12	HD24	16.9	3.54	1.40	8.9	2.38	1.10	8.10
C*(8,L)C*A12	UC18A	16.8	3.52	1.40	8.9	2.38	1.10	8.10
C*(8,L)C*B12	UC18B	16.7	3.48	1.41	8.8	2.38	1.08	8.00
C*9C*B12	UC18B	16.7	3.52	1.39	8.9	2.40	1.09	8.10
C*(8,L)C*A12	UC24A	17.2	3.64	1.38	9.3	2.48	1.10	8.30
C*(8,L)C*B12	UC24B	16.9	3.60	1.38	9.1	2.48	1.08	8.20
C*9C*B12	UC24B	17.2	3.66	1.38	9.3	2.50	1.09	8.30
C*(8,L)C*A12	UC30A	17.2	3.64	1.38	9.3	2.48	1.10	8.30
C*(8,L)C*B12	UC30B	16.9	3.60	1.38	9.1	2.48	1.08	8.20
C*9C*B12	UC30B	17.2	3.66	1.38	9.3	2.48	1.10	8.30
G*9V*A12	FC/MC/PC18A	16.8	3.44	1.43	8.7	2.28	1.12	8.00
G*9V*B12	FC/MC/PC18B	16.6	3.48	1.40	8.6	2.32	1.09	8.00
G*9V*A12	FC/MC/PC24A	17.1	3.56	1.41	9.3	2.42	1.13	8.20
G*9V*B12	FC/MC/PC24B	17.1	3.62	1.38	9.2	2.46	1.10	8.20
G*9V*A12	FC/MC/PC30A	17.1	3.56	1.41	9.3	2.42	1.13	8.20
G*9V*B12	FC/MC/PC30B	17.1	3.62	1.38	9.2	2.46	1.10	8.20
G*9V*A12	HC18	16.8	3.44	1.43	8.7	2.28	1.12	8.00
G*9V*A12	HD24	16.9	3.46	1.43	8.9	2.32	1.12	8.00
G*9V*B12	HD24	16.9	3.54	1.40	8.9	2.38	1.10	8.10
G*9V*A12	UC18A	16.9	3.48	1.42	9.0	2.34	1.13	8.00
G*9V*B12	UC18B	16.7	3.52	1.39	8.9	2.40	1.09	8.10
G*9V*A12	UC24A	17.2	3.58	1.41	9.4	2.44	1.13	8.20
G*9V*B12	UC24B	17.2	3.66	1.38	9.3	2.50	1.09	8.30
G*9V*A12	UC30A	17.2	3.58	1.41	9.4	2.44	1.13	8.20
G*9V*B12	UC30B	17.2	3.66	1.38	9.3	2.48	1.10	8.30

1. Rated CFM same as for cooling.

2. Heating MBH based on ARI standards of 70° DB entering indoor air, 72% RH outdoor air with 25 feet of interconnecting piping and no supplemental electric heat operation.

3. Variable speed furnaces have B.O.D (Blower on Delay) standard.

CP equals MBH output divided by (total KW input x 3.412).

HSPF (Heating Seasonal Performance Factor) is the total heating output during a normal annual usage period for heating divided by the total electric power input during the same period.

— = Not Applicable.

HEATING CAPACITY - CHJD24S21S1 With Variable Speed Furnaces

VARIABLE SPEED FURNACE	COIL ¹ MODEL	ARI HEATING ²						HSPF STD
		47°F			17°F			
		MBH	COP	KW	MBH	COP	KW	
13 SEER HP WITH VARIABLE SPEED FURNACES³								
(F,L)C8V*A12	FC/MC/PC/UC24A	23.0	3.94	1.68	12.0	2.58	1.34	8.00
FC9V*A12	FC/MC/PC/UC24A	23.0	3.92	1.68	12.0	2.58	1.34	8.00
FC9(C,V)*B12	FC/MC/PC/UC24B	23.0	3.94	1.68	12.0	2.58	1.34	8.00
(F,L)C8V*A12	FC/MC/PC/UC30A	23.0	3.94	1.68	12.0	2.58	1.34	8.00
FC9V*A12	FC/MC/PC/UC30A	23.0	3.94	1.68	12.0	2.58	1.34	8.00
FC9(C,V)*B12	FC/MC/PC/UC30B	23.0	3.94	1.68	12.0	2.58	1.34	8.00
(F,L)C8V*A12	FC/MC/PC/UC32A	23.0	3.94	1.68	12.0	2.58	1.34	8.00
FC9V*A12	FC/MC/PC/UC32A	23.0	3.94	1.68	12.0	2.58	1.34	8.00
FC9(C,V)*B12	FC/MC/PC/UC35B	23.0	3.96	1.67	12.0	2.58	1.34	8.00
(F,L)C8V*A12	HC30	23.0	3.94	1.68	12.0	2.58	1.34	8.00
FC9V*A12	HC30	23.0	3.94	1.68	12.0	2.58	1.34	8.00
FC9(C,V)*B12	HC36	23.0	3.96	1.67	12.0	2.58	1.34	8.00
C*(8,L)C*A12	FC/MC/PC24A	22.6	3.94	1.68	11.5	2.60	1.30	7.90
C*(8,L)C*B12	FC/MC/PC24B	22.4	3.98	1.65	11.4	2.62	1.28	7.90
C*9C*B12	FC/MC/PC24B	22.6	3.94	1.68	11.5	2.60	1.30	7.90
C*(8,L)C*A12	FC/MC/PC30A	22.6	3.94	1.68	11.5	2.60	1.30	7.90
C*(8,L)C*B12	FC/MC/PC30B	22.4	3.98	1.65	11.4	2.62	1.28	7.90
C*9C*B12	FC/MC/PC30B	22.6	3.94	1.68	11.5	2.60	1.30	7.90
C*(8,L)C*A12	FC/MC/PC32A	22.6	3.90	1.70	11.6	2.56	1.33	7.80
C*(8,L)C*B12	FC/MC/PC35B	22.4	3.96	1.66	11.4	2.60	1.29	7.90
C*9C*B12	FC/MC/PC35B	22.6	3.94	1.68	11.5	2.56	1.32	7.90
C*(8,L)C*A12	FC/MC/PC36A	22.6	3.98	1.66	11.4	2.54	1.32	7.90
C*(8,L)C*B12	FC/MC/PC36B	22.6	4.04	1.64	11.3	2.58	1.28	8.00
C*9C*B12	FC/MC/PC36B	22.6	4.00	1.66	11.4	2.56	1.31	8.00
C*(8,L)C*A12	FC/MC/PC37A	22.8	4.00	1.67	11.4	2.46	1.36	8.00
C*(8,L)C*B12	FC/MC/PC43B	22.6	4.02	1.65	11.3	2.52	1.31	8.00
C*9C*B12	FC/MC/PC43B	22.8	4.02	1.66	11.3	2.46	1.35	8.00
C*(8,L)C*A12	HC30	22.4	3.84	1.71	11.6	2.62	1.30	7.80
C*(8,L)C*B12	HC36	22.4	3.94	1.67	11.4	2.60	1.29	7.90
C*9C*B12	HC36	22.6	3.94	1.68	11.5	2.56	1.32	7.90
C*(8,L)C*A12	HD36	21.0	3.50	1.76	10.1	2.36	1.25	7.70
C*(8,L)C*B12	HD36	20.8	3.46	1.76	10.1	2.38	1.24	7.70
C*(8,L)C*C16	HD36	21.2	3.60	1.73	10.2	2.42	1.24	7.70
C*(8,L)C*C20	HD36	20.6	3.50	1.73	9.9	2.40	1.21	7.70
C*9C*B12	HD36	21.0	3.52	1.75	10.1	2.38	1.24	7.70
C*9C*C16	HD36	21.0	3.52	1.75	10.1	2.42	1.22	7.70
C*9C*C20	HD36	20.8	3.50	1.74	10.0	2.40	1.22	7.70
C*(8,L)C*A12	UC24A	22.6	3.98	1.66	11.4	2.58	1.30	7.90
C*(8,L)C*B12	UC24B	22.6	4.02	1.65	11.4	2.60	1.29	8.00
C*9C*B12	UC24B	22.6	3.98	1.66	11.5	2.58	1.31	7.90
C*(8,L)C*A12	UC30A	22.6	3.98	1.66	11.5	2.58	1.31	7.90
C*(8,L)C*B12	UC30B	22.6	4.02	1.65	11.4	2.60	1.29	8.00
C*9C*B12	UC30B	22.6	3.98	1.66	11.5	2.58	1.31	7.90
C*(8,L)C*A12	UC36A	22.4	3.90	1.68	11.4	2.60	1.29	7.80
C*(8,L)C*B12	UC36B	22.2	3.94	1.65	11.3	2.62	1.26	7.90
C*9C*B12	UC36B	22.4	3.90	1.68	11.4	2.60	1.29	7.80
G*9V*A12	FC/MC/PC24A	22.6	3.88	1.71	11.7	2.58	1.33	7.80
G*9V*B12	FC/MC/PC24B	22.6	3.94	1.68	11.5	2.60	1.30	7.90
G*9V*A12	FC/MC/PC30A	22.6	3.88	1.71	11.7	2.58	1.33	7.80
G*9V*B12	FC/MC/PC30B	22.6	3.94	1.68	11.5	2.60	1.30	7.90

For Notes See Page 20.

HEATING CAPACITY - CHJD24S21S1 With Variable Speed Furnaces (Continued)

VARIABLE SPEED FURNACE	COIL ¹ MODEL	ARI HEATING ²						
		47°F			17°F			HSPF
		MBH	COP	KW	MBH	COP	KW	STD
13 SEER HP WITH VARIABLE SPEED FURNACES³								
G*9V*A12	FC/MC/PC32A	22.8	3.84	1.74	11.7	2.52	1.36	7.80
G*9V*B12	FC/MC/PC35B	22.6	3.94	1.68	11.5	2.56	1.32	7.90
G*9V*A12	FC/MC/PC36A	22.8	3.94	1.70	11.5	2.52	1.34	7.90
G*9V*B12	FC/MC/PC36B	22.6	4.00	1.66	11.4	2.56	1.31	8.00
G*9V*A12	FC/MC/PC37A	22.8	3.96	1.69	11.4	2.44	1.37	8.00
G*9V*B12	FC/MC/PC43B	22.8	4.02	1.66	11.3	2.46	1.35	8.00
G*9V*A12	HC30	22.4	3.84	1.71	11.7	2.62	1.31	7.80
G*9V*B12	HC36	22.6	3.94	1.68	11.5	2.56	1.32	7.90
G*9V*A12	HD36	21.2	3.46	1.80	10.2	2.34	1.28	7.70
G*9V*B12	HD36	21.0	3.52	1.75	10.1	2.38	1.24	7.70
G*9V*C16	HD36	21.0	3.52	1.75	10.1	2.42	1.22	7.70
G*9V*C20	HD36	20.8	3.50	1.74	10.0	2.40	1.22	7.70
G*9V*A12	UC24A	22.6	3.92	1.69	11.6	2.56	1.33	7.90
G*9V*B12	UC24B	22.6	3.98	1.66	11.5	2.58	1.31	7.90
G*9V*A12	UC30A	22.6	3.92	1.69	11.6	2.56	1.33	7.90
G*9V*B12	UC30B	22.6	3.98	1.66	11.5	2.58	1.31	7.90
G*9V*A12	UC36A	22.4	3.84	1.71	11.5	2.56	1.32	7.80
G*9V*B12	UC36B	22.4	3.90	1.68	11.4	2.60	1.29	7.80

1. Rated CFM same as for cooling.

2. Heating MBH based on ARI standards of 70° DB entering indoor air, 72% RH outdoor air with 25 feet of interconnecting piping and no supplemental electric heat operation.

3. Variable speed furnaces have B.O.D (Blower on Delay) standard.
CP equals MBH output divided by (total KW input x 3.412).

HSPF (Heating Seasonal Performance Factor) is the total heating output during a normal annual usage period for heating divided by the total electric power input during the same period.

— = Not Applicable.

HEATING CAPACITY - CHJD30S21S1 With Variable Speed Furnaces

VARIABLE SPEED FURNACE	COIL ¹ MODEL	ARI HEATING ²						
		47°F			17°F			HSPF
		MBH	COP	KW	MBH	COP	KW	STD
13 SEER HP WITH VARIABLE SPEED FURNACES³								
(F,L)C8V*A12	FC/MC/PC/UC32A	29.0	3.68	2.29	15.0	2.30	1.85	7.85
FC9V*A12	FC/MC/PC/UC32A	29.0	3.66	2.30	15.0	2.30	1.85	7.80
(F,L)C8V*B16	FC/MC/PC/UC35B	28.0	3.76	2.21	14.0	2.36	1.77	7.95
(F,L)C8V*C16	FC/MC/PC/UC35C	28.0	3.78	2.20	14.0	2.36	1.77	7.95
(F,L)C8V*C20	FC/MC/PC/UC35C	29.0	3.66	2.30	15.0	2.30	1.87	7.85
FC9(C,V)*B12	FC/MC/PC/UC35B	29.0	3.70	2.26	14.0	2.32	1.83	7.85
FC9(C,V)*C16	FC/MC/PC/UC35C	29.0	3.74	2.24	14.0	2.34	1.80	7.90
(F,L)C8V*A12	FC/MC/PC/UC37A	29.0	3.66	2.30	15.0	2.30	1.85	7.80
FC9V*A12	FC/MC/PC/UC37A	29.0	3.66	2.30	15.0	2.30	1.85	7.80
(F,L)C8V*B16	FC/MC/PC/UC43B	28.0	3.76	2.21	14.0	2.36	1.77	7.95
(F,L)C8V*C16	FC/MC/PC/UC43C	28.0	3.78	2.20	14.0	2.38	1.76	8.00
(F,L)C8V*C20	FC/MC/PC/UC43C	29.0	3.68	2.29	15.0	2.30	1.85	7.85
FC9(C,V)*B12	FC/MC/PC/UC43B	29.0	3.72	2.25	14.0	2.34	1.81	7.90
FC9(C,V)*C16	FC/MC/PC/UC43C	29.0	3.74	2.24	14.0	2.34	1.80	7.90
(F,L)C8V*B16	HC36	28.0	3.76	2.21	14.0	2.36	1.77	7.95
FC9(C,V)*B12	HC36	29.0	3.70	2.26	14.0	2.32	1.83	7.85
(F,L)C8V*C16	HC42	28.0	3.78	2.20	14.0	2.38	1.76	8.00
(F,L)C8V*C20	HC42	29.0	3.68	2.29	15.0	2.32	1.84	7.85
FC9(C,V)*C16	HC42	29.0	3.74	2.24	14.0	2.34	1.80	7.90
C*(8,L)C*A12	FC/MC/PC32A	28.8	3.52	2.40	14.9	2.24	1.95	7.70
C*(8,L)C*B12	FC/MC/PC35B	28.4	3.66	2.27	14.5	2.32	1.83	7.80
C*9C*B12	FC/MC/PC35B	28.6	3.58	2.34	14.7	2.28	1.89	7.80
C*(8,L)C*C16	FC/MC/PC35C	28.2	3.68	2.25	14.4	2.34	1.80	7.80
C*(8,L)C*C20	FC/MC/PC35C	28.4	3.70	2.25	14.5	2.34	1.82	7.90
C*9C*C16	FC/MC/PC35C	28.2	3.66	2.26	14.4	2.34	1.80	7.80
C*9C*C20	FC/MC/PC35C	28.2	3.68	2.25	14.4	2.34	1.80	7.80
C*(8,L)C*A12	FC/MC/PC36A	28.4	3.60	2.31	14.6	2.30	1.86	7.80
C*(8,L)C*B12	FC/MC/PC36B	28.2	3.66	2.26	14.5	2.34	1.82	7.80
C*9C*B12	FC/MC/PC36B	28.2	3.64	2.27	14.5	2.34	1.82	7.80
C*(8,L)C*C16	FC/MC/PC36C	28.2	3.70	2.23	14.4	2.36	1.79	7.80
C*(8,L)C*C20	FC/MC/PC36C	28.2	3.70	2.23	14.4	2.38	1.77	7.90
C*9C*C16	FC/MC/PC36C	28.2	3.70	2.23	14.4	2.36	1.79	7.80
C*9C*C20	FC/MC/PC36C	28.4	3.68	2.26	14.5	2.34	1.82	7.80
C*(8,L)C*A12	FC/MC/PC37A	28.6	3.62	2.32	14.7	2.30	1.87	7.80
C*(8,L)C*B12	FC/MC/PC43B	28.6	3.70	2.27	14.6	2.36	1.81	7.90
C*9C*B12	FC/MC/PC43B	28.6	3.64	2.30	14.7	2.32	1.86	7.80
C*(8,L)C*C16	FC/MC/PC43C	28.4	3.78	2.20	14.4	2.40	1.76	7.90
C*(8,L)C*C20	FC/MC/PC43C	28.4	3.78	2.20	14.4	2.40	1.76	7.90
C*9C*C16	FC/MC/PC43C	28.6	3.70	2.27	14.6	2.34	1.83	7.90
C*9C*C20	FC/MC/PC43C	28.4	3.76	2.21	14.5	2.38	1.79	7.90
C*(8,L)C*B12	HC36	28.2	3.60	2.30	14.5	2.32	1.83	7.80
C*9C*B12	HC36	28.6	3.58	2.34	14.7	2.28	1.89	7.80
C*(8,L)C*C16	HC42	28.4	3.76	2.21	14.4	2.40	1.76	7.90
C*(8,L)C*C20	HC42	28.4	3.78	2.20	14.4	2.40	1.76	7.90
C*9C*C16	HC42	28.6	3.70	2.27	14.6	2.34	1.83	7.90
C*9C*C20	HC42	28.4	3.74	2.23	14.5	2.38	1.79	7.90
C*(8,L)C*A12	HD36	27.2	3.26	2.45	13.2	2.04	1.90	7.70
C*(8,L)C*B12	HD36	27.0	3.30	2.40	13.1	2.06	1.86	7.70
C*(8,L)C*C16	HD36	27.0	3.32	2.38	13.1	2.08	1.85	7.70

For Notes See Page 22.

HEATING CAPACITY - CHJD30S21S1 With Variable Speed Furnaces (Continued)

VARIABLE SPEED FURNACE	COIL ¹ MODEL	ARI HEATING ²						
		47°F			17°F			HSPF
		MBH	COP	KW	MBH	COP	KW	STD
13 SEER HP WITH VARIABLE SPEED FURNACES³								
C*(8,L)C*C20	HD36	27.2	3.38	2.36	13.2	2.10	1.84	7.70
C*9C*B12	HD36	27.0	3.30	2.40	13.1	2.06	1.86	7.70
C*9C*C16	HD36	27.0	3.32	2.38	13.1	2.08	1.85	7.70
C*9C*C20	HD36	27.0	3.30	2.40	13.1	2.06	1.86	7.70
C*(8,L)C*A12	UC36A	28.2	3.54	2.33	13.9	2.20	1.85	7.70
C*(8,L)C*B12	UC36B	28.0	3.58	2.29	13.8	2.22	1.82	7.70
C*9C*B12	UC36B	28.2	3.58	2.31	13.8	2.22	1.82	7.70
C*(8,L)C*C16	UC36C	28.0	3.62	2.27	13.8	2.24	1.81	7.70
C*(8,L)C*C20	UC36C	28.0	3.62	2.27	13.8	2.24	1.81	7.70
C*9C*C16	UC36C	28.0	3.62	2.27	13.8	2.24	1.81	7.70
C*9C*C20	UC36C	28.0	3.60	2.28	13.8	2.24	1.81	7.70
G*9V*A12	FC/MC/PC32A	28.4	3.58	2.33	14.6	2.28	1.88	7.70
G*9V*B12	FC/MC/PC35B	28.6	3.58	2.34	14.7	2.28	1.89	7.80
G*9V*C16	FC/MC/PC35C	28.2	3.66	2.26	14.4	2.34	1.80	7.80
G*9V*C20	FC/MC/PC35C	28.2	3.68	2.25	14.4	2.34	1.80	7.80
G*9V*B12	FC/MC/PC36B	28.2	3.64	2.27	14.5	2.34	1.82	7.80
G*9V*A12	FC/MC/PC36A	28.4	3.60	2.31	14.6	2.30	1.86	7.80
G*9V*C16	FC/MC/PC36C	28.2	3.70	2.23	14.4	2.36	1.79	7.80
G*9V*C20	FC/MC/PC36C	28.4	3.68	2.26	14.5	2.34	1.82	7.80
G*9V*A12	FC/MC/PC37A	28.8	3.64	2.32	14.8	2.30	1.89	7.80
G*9V*B12	FC/MC/PC43B	28.6	3.64	2.30	14.7	2.32	1.86	7.80
G*9V*C16	FC/MC/PC43C	28.6	3.70	2.27	14.6	2.34	1.83	7.90
G*9V*C20	FC/MC/PC43C	28.4	3.76	2.21	14.5	2.38	1.79	7.90
G*9V*B12	HC36	28.6	3.58	2.34	14.7	2.28	1.89	7.80
G*9V*C16	HC42	28.6	3.70	2.27	14.6	2.34	1.83	7.90
G*9V*C20	HC42	28.4	3.74	2.23	14.5	2.38	1.79	7.90
G*9V*A12	HD36	27.2	3.26	2.45	13.2	2.02	1.92	7.30
G*9V*B12	HD36	27.0	3.30	2.40	13.1	2.06	1.86	7.70
G*9V*C16	HD36	27.0	3.32	2.38	13.1	2.08	1.85	7.70
G*9V*C20	HD36	27.0	3.30	2.40	13.1	2.06	1.86	7.70
G*9V*A12	UC36A	28.2	3.54	2.33	13.9	2.18	1.87	7.70
G*9V*B12	UC36B	28.2	3.58	2.31	13.8	2.22	1.82	7.70
G*9V*C16	UC36C	28.0	3.62	2.27	13.8	2.24	1.81	7.70
G*9V*C20	UC36C	28.0	3.60	2.28	13.8	2.24	1.81	7.70

1. Rated CFM same as for cooling.

2. Heating MBH based on ARI standards of 70° DB entering indoor air, 72% RH outdoor air with 25 feet of interconnecting piping and no supplemental electric heat operation.

3. Variable speed furnaces have B.O.D (Blower on Delay) standard.

CP equals MBH output divided by (total KW input x 3.412).

HSPF (Heating Seasonal Performance Factor) is the total heating output during a normal annual usage period for heating divided by the total electric power input during the same period.

— = Not Applicable.

HEATING CAPACITY - CHJD36S21S1 With Variable Speed Furnaces

VARIABLE SPEED FURNACE	COIL ¹ MODEL	ARI HEATING ²						
		47°F			17°F			HSPF
		MBH	COP	KW	MBH	COP	KW	STD
13 SEER HP WITH VARIABLE SPEED FURNACES³								
(F,L)C8V*A12	FC/MC/PC/UC37A	34.0	3.66	2.68	20.0	2.56	2.31	8.65
FC9V*A12	FC/MC/PC/UC37A	34.0	3.60	2.76	20.0	2.54	2.35	8.55
(F,L)C8V*B16	FC/MC/PC/UC43B	33.0	3.74	2.61	20.0	2.62	2.23	8.80
(F,L)C8V*C16	FC/MC/PC/UC43C	33.0	3.76	2.60	20.0	2.64	2.21	8.85
(F,L)C8V*C20	FC/MC/PC/UC43C	33.0	3.70	2.64	20.0	2.60	2.25	8.75
FC9(C,V)*B12	FC/MC/PC/UC43B	34.0	3.68	2.67	20.0	2.58	2.29	8.70
FC9(C,V)*C16	FC/MC/PC/UC43C	33.0	3.74	2.61	20.0	2.62	2.23	8.80
FC9(C,V)*C20	FC/MC/PC/UC43C	33.0	3.74	2.61	20.0	2.62	2.23	8.80
(F,L)C8V*C16	FC/MC/PC/UC48C	33.0	3.78	2.57	20.0	2.66	2.19	8.90
(F,L)C8V*C20	FC/MC/PC/UC48C	33.0	3.72	2.63	20.0	2.60	2.25	8.75
FC9(C,V)*C16	FC/MC/PC/UC48C	33.0	3.76	2.60	20.0	2.64	2.21	8.85
FC9(C,V)*C20	FC/MC/PC/UC48C	33.0	3.76	2.60	20.0	2.64	2.21	8.85
FC9(C,V)*D20	FC/MC/PC/UC48D	33.0	3.76	2.60	20.0	2.64	2.21	8.85
(F,L)C8V*C16	HC42	33.0	3.76	2.58	20.0	2.64	2.21	8.85
(F,L)C8V*C20	HC42	33.0	3.72	2.63	20.0	2.60	2.25	8.75
FC9(C,V)*C16	HC42	33.0	3.74	2.61	20.0	2.62	2.23	8.80
FC9(C,V)*C20	HC42	33.0	3.76	2.60	20.0	2.64	2.21	8.85
C*(8,L)C*A12	FC/MC/PC37A	32.6	3.56	2.68	19.0	2.58	2.16	8.40
C*(8,L)C*B12	FC/MC/PC43B	33.8	3.66	2.71	19.8	2.58	2.25	8.60
C*9C*B12	FC/MC/PC43B	33.8	3.66	2.71	19.8	2.58	2.25	8.60
C*(8,L)C*C16	FC/MC/PC43C	33.4	3.76	2.60	19.5	2.64	2.16	8.70
C*(8,L)C*C20	FC/MC/PC43C	33.4	3.78	2.59	19.3	2.66	2.13	8.70
C*9C*C16	FC/MC/PC43C	33.8	3.70	2.68	19.7	2.60	2.22	8.60
C*9C*C20	FC/MC/PC43C	33.6	3.76	2.62	19.5	2.64	2.16	8.70
C*(8,L)C*C16	FC/MC/PC48C	33.4	3.80	2.58	19.5	2.68	2.13	8.70
C*(8,L)C*C20	FC/MC/PC48C	33.4	3.84	2.55	19.4	2.70	2.11	8.80
C*9C*C16	FC/MC/PC48C	33.6	3.78	2.61	19.6	2.64	2.18	8.70
C*9C*C20	FC/MC/PC48C	33.8	3.76	2.63	19.9	2.60	2.24	8.70
C*(8,L)C*C16	HC42	33.4	3.76	2.60	19.5	2.64	2.16	8.70
C*(8,L)C*C20	HC42	33.4	3.80	2.58	19.4	2.66	2.14	8.70
C*9C*C16	HC42	33.8	3.70	2.68	19.7	2.60	2.22	8.60
C*9C*C20	HC42	33.6	3.76	2.62	19.5	2.64	2.16	8.70
C*(8,L)C*B12	HD48	32.6	3.46	2.76	18.0	2.38	2.22	8.30
C*(8,L)C*C16	HD48	32.4	3.52	2.70	17.7	2.42	2.14	8.30
C*(8,L)C*C20	HD48	32.2	3.56	2.65	17.6	2.44	2.11	8.30
C*9C*B12	HD48	32.6	3.44	2.78	18.1	2.36	2.25	8.30
C*9C*C16	HD48	32.4	3.50	2.71	17.8	2.40	2.17	8.30
C*9C*C20	HD48	33.0	3.52	2.75	18.4	2.40	2.25	8.40
C*(8,L)C*C16	UC48C	33.4	3.86	2.54	19.8	2.70	2.15	8.70
C*(8,L)C*C20	UC48C	33.4	3.90	2.51	19.7	2.72	2.12	8.70
C*9C*C16	UC48C	33.6	3.82	2.58	19.9	2.68	2.18	8.70
C*9C*C20	UC48C	34.0	3.80	2.62	20.4	2.64	2.26	8.70
G*9V*A12	FC/MC/PC37A	32.8	3.54	2.72	19.5	2.54	2.25	8.30
G*9V*B12	FC/MC/PC43B	33.8	3.66	2.71	19.8	2.58	2.25	8.60
G*9V*C16	FC/MC/PC43C	33.8	3.70	2.68	19.7	2.60	2.22	8.60
G*9V*C20	FC/MC/PC43C	33.6	3.76	2.62	19.5	2.64	2.16	8.70
G*9V*C16	FC/MC/PC48C	33.6	3.78	2.61	19.6	2.64	2.18	8.70
G*9V*C20	FC/MC/PC48C	33.8	3.76	2.63	19.9	2.60	2.24	8.70
G*9V*C16	HC42	33.8	3.70	2.68	19.7	2.60	2.22	8.60

For Notes See Page 24.

HEATING CAPACITY - CHJD36S21S1 With Variable Speed Furnaces (Continued)

VARIABLE SPEED FURNACE	COIL ¹ MODEL	ARI HEATING ²						
		47°F			17°F			HSPF
		MBH	COP	KW	MBH	COP	KW	STD
13 SEER HP WITH VARIABLE SPEED FURNACES³								
G*9V*C20	HC42	33.6	3.76	2.62	19.5	2.64	2.16	8.70
G*9V*B12	HD48	32.6	3.44	2.78	18.1	2.36	2.25	8.30
G*9V*C16	HD48	32.4	3.50	2.71	17.8	2.40	2.17	8.30
G*9V*C20	HD48	33.0	3.52	2.75	18.4	2.40	2.25	8.40
G*9V*C16	UC48C	33.6	3.82	2.58	19.9	2.68	2.18	8.70
G*9V*C20	UC48C	34.0	3.80	2.62	20.4	2.64	2.26	8.70

1. Rated CFM same as for cooling.

2. Heating MBH based on ARI standards of 70° DB entering indoor air, 72% RH outdoor air with 25 feet of interconnecting piping and no supplemental electric heat operation.

3. Variable speed furnaces have B.O.D (Blower on Delay) standard.
CP equals MBH output divided by (total KW input x 3.412).

HSPF (Heating Seasonal Performance Factor) is the total heating output during a normal annual usage period for heating divided by the total electric power input during the same period.

— = Not Applicable.

HEATING CAPACITY - CHJD42S21S1 With Variable Speed Furnaces

VARIABLE SPEED FURNACE	COIL ¹ MODEL	ARI HEATING ²						
		47°F			17°F			HSPF
		MBH	COP	KW	MBH	COP	KW	STD
13 SEER HP WITH VARIABLE SPEED FURNACES³								
(F,L)C8V*C16	FC/MC/PC/UC48C	41.0	3.62	3.31	25.0	2.68	2.68	8.70
(F,L)C8V*C20	FC/MC/PC/UC48C	41.0	3.64	3.30	24.0	2.70	2.64	8.75
FC9(C,V)*C16	FC/MC/PC/UC48C	41.0	3.60	3.33	25.0	2.66	2.70	8.65
FC9(C,V)*C20	FC/MC/PC/UC48C	41.0	3.62	3.31	25.0	2.68	2.68	8.70
FC9(C,V)*D20	FC/MC/PC/UC48D	41.0	3.60	3.33	25.0	2.68	2.68	8.70
(F,L)C8V*C16	FC/PC/UC60C	41.0	3.62	3.31	24.0	2.68	2.66	8.70
(F,L)C8V*C20	FC/PC/UC60C	41.0	3.64	3.30	24.0	2.70	2.64	8.75
FC9(C,V)*C16	FC/PC/UC60C	41.0	3.60	3.33	25.0	2.66	2.70	8.65
FC9(C,V)*C20	FC/PC/UC60C	41.0	3.62	3.31	24.0	2.68	2.66	8.70
FC9(C,V)*D20	FC/MC/PC/UC60D	41.0	3.62	3.31	25.0	2.68	2.68	8.70
C*(8,L)C*C16	FC/MC/PC48C	41.5	3.68	3.31	24.6	2.70	2.67	8.70
C*(8,L)C*C20	FC/MC/PC48C	41.5	3.70	3.29	24.4	2.72	2.63	8.70
C*9C*C16	FC/MC/PC48C	42.0	3.64	3.38	24.6	2.68	2.69	8.60
C*9C*C20	FC/MC/PC48C	42.0	3.62	3.40	24.8	2.66	2.73	8.60
C*9C*D20	FC/MC/PC48D	41.5	3.66	3.32	24.6	2.68	2.69	8.70
C*9C*D20	FC/MC/PC60D	42.0	3.74	3.29	24.8	2.72	2.67	8.80
C*(8,L)C*C16	FC/PC60C	42.0	3.76	3.27	24.8	2.74	2.65	8.80
C*(8,L)C*C20	FC/PC60C	42.0	3.80	3.24	24.6	2.78	2.59	8.80
C*9C*C16	FC/PC60C	42.5	3.66	3.40	25.0	2.66	2.75	8.70
C*9C*C20	FC/PC60C	42.0	3.72	3.31	24.8	2.70	2.69	8.70
C*(8,L)C*B12	HD48	41.0	3.36	3.58	23.6	2.48	2.79	8.30
C*(8,L)C*C16	HD48	41.0	3.46	3.47	23.6	2.54	2.72	8.50
C*(8,L)C*C20	HD48	41.0	3.48	3.45	23.4	2.56	2.68	8.50
C*9C*B12	HD48	39.5	3.26	3.55	22.8	2.46	2.72	8.10
C*9C*C16	HD48	41.0	3.44	3.49	23.6	2.52	2.74	8.40
C*9C*C20	HD48	41.0	3.42	3.51	23.8	2.52	2.77	8.40
C*9C*D20	HD48	41.0	3.46	3.47	23.6	2.54	2.72	8.40
C*(8,L)C*C16	UC48C	42.0	3.72	3.31	24.6	2.72	2.65	8.70
C*(8,L)C*C20	UC48C	42.0	3.74	3.29	24.6	2.74	2.63	8.80
C*9C*C16	UC48C	42.0	3.68	3.34	24.8	2.70	2.69	8.70

For Notes See Page 25.

HEATING CAPACITY - CHJD42S21S1 With Variable Speed Furnaces (Continued)

VARIABLE SPEED FURNACE	COIL ¹ MODEL	ARI HEATING ²						
		47°F			17°F			HSPF
		MBH	COP	KW	MBH	COP	KW	STD
13 SEER HP WITH VARIABLE SPEED FURNACES³								
C*9C*C20	UC48C	42.0	3.68	3.34	24.8	2.68	2.71	8.70
C*9C*D20	UC48D	42.0	3.70	3.33	24.8	2.70	2.69	8.70
C*(8,L)C*C16	UC60C	42.0	3.72	3.31	24.2	2.70	2.63	8.70
C*(8,L)C*C20	UC60C	41.5	3.76	3.23	24.2	2.72	2.61	8.80
C*9C*C16	UC60C	42.0	3.64	3.38	24.6	2.62	2.75	8.70
C*9C*C20	UC60C	42.0	3.68	3.34	24.4	2.66	2.69	8.70
C*9C*D20	UC60D	42.0	3.70	3.33	24.4	2.68	2.67	8.70
G*9V*C16	FC/MC/PC48C	42.0	3.64	3.38	24.6	2.68	2.69	8.60
G*9V*C20	FC/MC/PC48C	42.0	3.62	3.40	24.8	2.66	2.73	8.60
G*9V*D20	FC/MC/PC48D	41.5	3.66	3.32	24.6	2.68	2.69	8.70
G*9V*D20	FC/MC/PC60D	42.0	3.74	3.29	24.8	2.72	2.67	8.80
G*9V*C16	FC/PC60C	42.5	3.66	3.40	25.0	2.66	2.75	8.70
G*9V*C20	FC/PC60C	42.0	3.72	3.31	24.8	2.70	2.69	8.70
G*9V*B12	HD48	39.5	3.26	3.55	22.8	2.46	2.72	8.10
G*9V*C16	HD48	41.0	3.44	3.49	23.6	2.52	2.74	8.40
G*9V*C20	HD48	41.0	3.42	3.51	23.8	2.52	2.77	8.40
G*9V*D20	HD48	41.0	3.46	3.47	23.6	2.54	2.72	8.40
G*9V*C16	UC48C	42.0	3.68	3.34	24.8	2.70	2.69	8.70
G*9V*C20	UC48C	42.0	3.68	3.34	24.8	2.68	2.71	8.70
G*9V*D20	UC48D	42.0	3.70	3.33	24.8	2.70	2.69	8.70
G*9V*C16	UC60C	42.0	3.64	3.38	24.6	2.62	2.75	8.70
G*9V*C20	UC60C	42.0	3.68	3.34	24.4	2.66	2.69	8.70
G*9V*D20	UC60D	42.0	3.70	3.33	24.4	2.68	2.67	8.70

1. Rated CFM same as for cooling.

2. Heating MBH based on ARI standards of 70° DB entering indoor air, 72% RH outdoor air with 25 feet of interconnecting piping and no supplemental electric heat operation.

3. Variable speed furnaces have B.O.D (Blower on Delay) standard.
CP equals MBH output divided by (total KW input x 3.412).

HSPF (Heating Seasonal Performance Factor) is the total heating output during a normal annual usage period for heating divided by the total electric power input during the same period.

— = Not Applicable.

HEATING CAPACITY - CHJD48S21S1 With Variable Speed Furnaces

VARIABLE SPEED FURNACE	COIL ¹ MODEL	ARI HEATING ²						
		47°F			17°F			HSPF
		MBH	COP	KW	MBH	COP	KW	STD
13 SEER HP WITH VARIABLE SPEED FURNACES³								
(F,L)C8V*C16	FC/PC/UC60C	48.0	3.42	4.06	37.0	2.76	3.92	7.80
(F,L)C8V*C20	FC/PC/UC60C	48.0	3.44	4.04	37.0	2.78	3.92	8.00
FC9(C,V)*C16	FC/PC/UC60C	47.0	3.40	4.05	37.0	2.76	3.97	7.80
FC9(C,V)*C20	FC/PC/UC60C	48.0	3.42	4.06	37.0	2.76	3.94	8.00
FC9(C,V)*D20	FC/MC/PC/UC60D	48.0	3.44	4.04	37.0	2.78	3.92	8.00
(F,L)C8V*C20	FC/MC62D	48.0	3.44	4.04	37.0	2.78	3.92	8.00
FC9(C,V)*C20	FC/MC62D	48.0	3.42	4.06	37.0	2.76	3.94	8.00
FC9(C,V)*D20	FC/MC62D	48.0	3.44	4.04	37.0	2.78	3.92	8.00
C*9C*D20	FC/MC/PC60D	47.5	3.38	4.12	37.2	2.74	3.98	7.80
C*9C*D20	FC/MC62D	48.0	3.46	4.07	36.8	2.74	3.94	7.80
C*(8,L)C*C16	FC/PC60C	47.5	3.40	4.09	37.2	2.76	3.95	7.80
C*(8,L)C*C20	FC/PC60C	47.5	3.44	4.05	36.8	2.78	3.88	7.80
C*9C*C16	FC/PC60C	48.0	3.38	4.16	37.4	2.74	4.00	7.70
C*9C*C20	FC/PC60C	48.0	3.38	4.16	37.4	2.74	4.00	7.70

For Notes See Page 26.

HEATING CAPACITY - CHJD48S21S1 With Variable Speed Furnaces (Continued)

VARIABLE SPEED FURNACE	COIL ¹ MODEL	ARI HEATING ²						
		47°F			17°F			HSPF
		MBH	COP	KW	MBH	COP	KW	STD
13 SEER HP WITH VARIABLE SPEED FURNACES³								
C*9C*D20	HC60	48.0	3.50	4.02	37.2	2.80	3.89	7.80
C*(8,L)C*C16	HD60	47.5	3.24	4.30	37.0	2.64	4.11	7.70
C*(8,L)C*C20	HD60	47.5	3.28	4.24	36.8	2.66	4.05	7.80
C*9C*C16	HD60	47.5	3.22	4.32	37.2	2.62	4.16	7.70
C*9C*C20	HD60	47.5	3.22	4.32	37.2	2.62	4.16	7.70
C*9C*D20	HD60	47.5	3.22	4.32	37.0	2.62	4.14	7.70
C*(8,L)C*C16	UC60C	47.5	3.48	4.00	36.8	2.78	3.88	7.80
C*(8,L)C*C20	UC60C	47.5	3.52	3.95	36.6	2.82	3.80	7.80
C*9C*C16	UC60C	48.0	3.44	4.09	37.0	2.76	3.93	7.80
C*9C*C20	UC60C	48.0	3.44	4.09	37.0	2.76	3.93	7.80
C*9C*D20	UC60D	48.0	3.46	4.07	37.0	2.78	3.90	7.80
G*9V*D20	FC/MC/PC60D	47.5	3.38	4.12	37.2	2.74	3.98	7.80
G*9V*D20	FC/MC62D	48.0	3.46	4.07	36.8	2.74	3.94	7.80
G*9V*C16	FC/PC60C	48.0	3.38	4.16	37.4	2.74	4.00	7.70
G*9V*C20	FC/PC60C	48.0	3.38	4.16	37.4	2.74	4.00	7.70
G*9V*D20	HC60	48.0	3.50	4.02	37.2	2.80	3.89	7.80
G*9V*C16	HD60	47.5	3.22	4.32	37.2	2.62	4.16	7.70
G*9V*C20	HD60	47.5	3.22	4.32	37.2	2.62	4.16	7.70
G*9V*D20	HD60	47.5	3.22	4.32	37.0	2.62	4.14	7.70
G*9V*C16	UC60C	48.0	3.44	4.09	37.0	2.76	3.93	7.80
G*9V*C20	UC60C	48.0	3.44	4.09	37.0	2.76	3.93	7.80
G*9V*D20	UC60D	48.0	3.46	4.07	37.0	2.78	3.90	7.80

1. Rated CFM same as for cooling.

2. Heating MBH based on ARI standards of 70° DB entering indoor air, 72% RH outdoor air with 25 feet of interconnecting piping and no supplemental electric heat operation.

3. Variable speed furnaces have B.O.D (Blower on Delay) standard.
CP equals MBH output divided by (total KW input x 3.412).

HSPF (Heating Seasonal Performance Factor) is the total heating output during a normal annual usage period for heating divided by the total electric power input during the same period.

— = Not Applicable.

HEATING CAPACITY - THGD60S21S1 With Variable Speed Furnaces

VARIABLE SPEED FURNACE	COIL ¹ MODEL	ARI HEATING ²						
		47°F			17°F			HSPF
		MBH	COP	KW	MBH	COP	KW	STD
13 SEER HP WITH VARIABLE SPEED FURNACES³								
(F,L)C8V*C20	FC/MC62D	58.0	3.48	4.84	39.0	2.38	4.80	7.70
FC9(C,V)*C20	FC/MC62D	57.0	3.48	4.79	38.0	2.38	4.73	7.70
FC9(C,V)*D20	FC/MC62D	56.0	3.50	4.68	38.0	2.38	4.73	7.75
C*(8,L)C*C20	FC/MC62D	57.0	3.48	4.80	39.5	2.40	4.82	7.80
C*9C*C20	FC/MC62D	57.5	3.42	4.93	39.5	2.36	4.91	7.80
C*9C*D20	FC/MC62D	57.5	3.42	4.93	39.5	2.36	4.91	7.80
G*9V*C20	FC/MC62D	57.5	3.42	4.93	39.5	2.36	4.91	7.80
G*9V*D20	FC/MC62D	57.5	3.42	4.93	39.5	2.36	4.91	7.80

1. Rated CFM same as for cooling.

2. Heating MBH based on ARI standards of 70° DB entering indoor air, 72% RH outdoor air with 25 feet of interconnecting piping and no supplemental electric heat operation.

3. Variable speed furnaces have B.O.D (Blower on Delay) standard.
CP equals MBH output divided by (total KW input x 3.412).

HSPF (Heating Seasonal Performance Factor) is the total heating output during a normal annual usage period for heating divided by the total electric power input during the same period.

— = Not Applicable.

ACCESSORIES

Refer to Price Manual for specific model numbers.

Start Assist Kit (2SA067*)

Blower Time Delay - Available to increase efficiency when installed. Installs on indoor section and maintains blower for approximately one minute after cooling thermostat has been satisfied.

Hard Start Kits - Provides required starting torque for use with Thermal Expansion Valve Kit.

Low Temperature Cutout (2LT06700224) - Prevents heat pump operation below -10°F ambient temperature.

Compressor Blanket - Designed to further reduce the normal operating sound.

Add-on Fossil Fuel Control - Interface controls for use with gas, oil furnaces and the heat pump system are available.

Thermal Expansion Valve Kit - 1TVM Series TXV kit used to improve system performance.

Outdoor Thermostat (2TD06700124) - Provides additional staging of supplemental electric heat.

Room Thermostats - A wide selection of matching thermostats is available to provide features required for any installation.

2H/1C, manual changeover electronic non-programmable thermostat.

3H/2C, non-programmable digital thermostat.

3H/2C, auto/manual changeover, electronic programmable, 7-day, hardwire thermostat.

* For the most current accessory information, refer to the price book or consult factory.

SOUND POWER RATINGS

UNIT MODEL	(dBA)*	
	Cooling	Heating
018	71.0	71.3
024	75.8	77.3
030	76.2	77.2
036	74.7	76.4
042	73.9	77.9
048	74.8	77.0
060	76.7	78.1

* Rated in accordance with ARI 270-95 Standards.

TYPICAL INSTALLATION

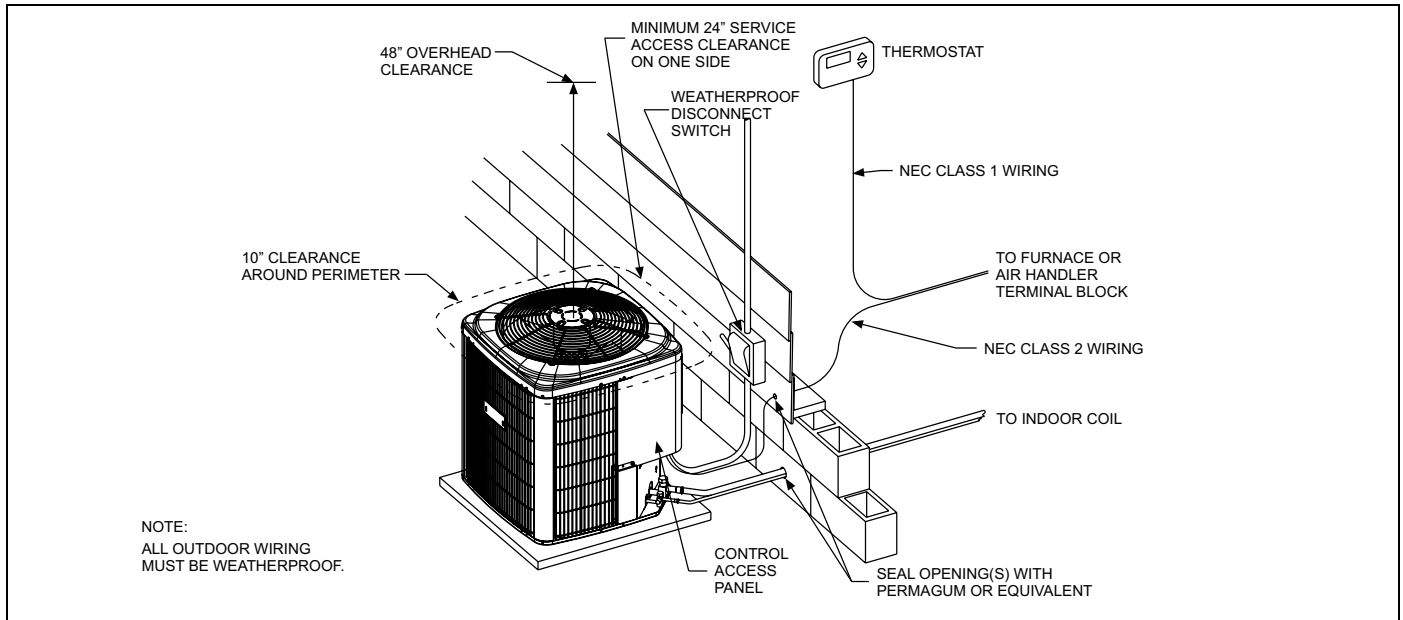

TYPICAL FIELD WIRING

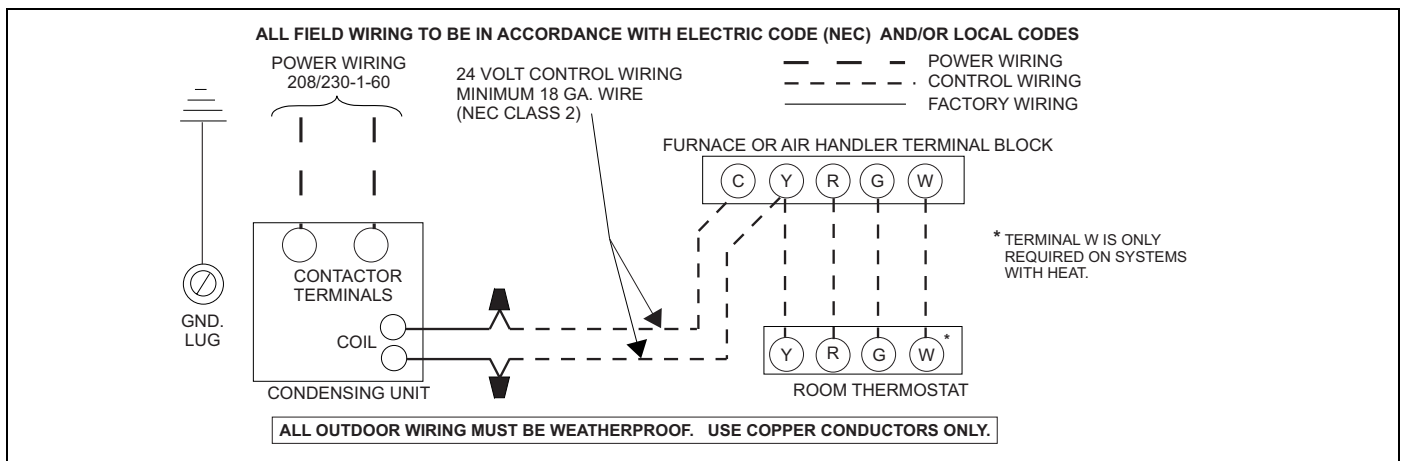

COOLING PERFORMANCE DATA																
CONDENSING UNIT MODEL NO.		CHJD18S21S1														
INDOOR COIL MODEL NO.		AHP18														
CONDENSING ENTERING AIR TEMPERATURE	IDCFM	450					600					750				
	ID DB (°F)	80	80	75	80	80	80	80	75	80	80	80	80	75	80	80
	ID WB (°F)	57	62	62	67	72	57	62	62	67	72	57	62	62	67	72
65	T.C.	16.6	18.5	18.3	20.4	22.0	18.9	20.1	19.8	22.0	24.0	21.2	21.7	21.3	23.6	25.9
	S.C.	13.3	13.3	13.7	13.6	12.7	13.3	13.3	13.5	13.5	13.1	13.3	13.3	13.3	13.3	13.4
	KW	1.1	1.1	1.1	1.1	1.1	1.1	1.1	1.1	1.1	1.1	1.1	1.1	1.1	1.1	1.2
75	T.C.	15.6	17.4	17.2	19.2	20.9	17.8	18.8	18.6	20.7	22.6	20.0	20.2	20.0	22.1	24.3
	S.C.	13.3	13.3	13.3	13.3	12.0	13.3	13.3	13.3	13.3	12.7	13.3	13.3	13.3	13.3	13.3
	KW	1.1	1.2	1.2	1.2	1.2	1.2	1.2	1.2	1.2	1.2	1.2	1.2	1.2	1.2	1.3
85	T.C.	14.6	16.3	16.2	18.1	19.7	16.7	17.5	17.4	19.3	21.2	18.9	18.7	18.6	20.6	22.7
	S.C.	13.3	13.3	12.8	12.9	11.3	13.3	13.3	13.1	13.1	12.2	13.3	13.3	13.3	13.3	13.2
	KW	1.2	1.2	1.2	1.3	1.3	1.3	1.3	1.3	1.3	1.3	1.3	1.3	1.3	1.3	1.4
95	T.C.	13.6	15.2	15.1	16.9	18.5	15.7	16.2	16.1	18.0	19.7	17.7	17.2	17.2	19.1	21.0
	S.C.	13.3	13.3	12.4	12.5	10.7	13.3	13.3	12.8	12.9	11.8	13.3	13.3	13.3	13.3	13.0
	KW	1.3	1.3	1.3	1.4	1.4	1.3	1.4	1.4	1.4	1.4	1.4	1.4	1.4	1.4	1.5
105	T.C.	12.9	14.1	14.0	15.7	17.3	14.8	15.2	14.9	16.7	18.3	16.6	16.2	15.8	17.6	19.4
	S.C.	12.9	13.1	11.8	11.9	10.0	13.3	13.2	12.5	12.6	11.2	13.3	13.3	13.3	13.3	12.4
	KW	1.4	1.4	1.4	1.4	1.5	1.4	1.4	1.4	1.5	1.5	1.5	1.5	1.5	1.5	1.6
115	T.C.	12.3	13.0	12.9	14.5	16.1	13.9	14.1	13.6	15.3	16.9	15.4	15.2	14.3	16.1	17.8
	S.C.	12.3	13.0	11.2	11.3	9.3	13.3	13.1	12.2	12.3	10.5	13.3	13.3	13.3	13.3	11.7
	KW	1.5	1.5	1.5	1.5	1.6	1.5	1.5	1.5	1.6	1.6	1.6	1.6	1.5	1.6	1.7
125	T.C.	11.7	12.0	11.9	13.3	14.8	13.0	13.1	12.4	14.0	15.5	14.2	14.2	12.9	14.6	16.2
	S.C.	11.7	12.0	10.6	10.7	8.7	13.0	13.1	11.9	12.0	9.8	13.3	13.3	12.9	13.3	11.0
	KW	1.5	1.6	1.6	1.6	1.7	1.6	1.6	1.6	1.7	1.7	1.7	1.7	1.6	1.7	1.8

NOTE: ALL CAPACITIES INCLUDE INDOOR FAN HEAT AT 1250 BTUH/1000 CFM.

Multipliers for determining the performance with other indoor sections.

NOTE: For dry bulb temperatures different than those listed (between 73-87 F), sensible capacity increases by 1060 BTUH per 1000 CFM per degree above the listed temperature and decreases by 1060 BTUH per 1000 CFM per degree below the listed temperature.

Air Handler	Coil	T.C.	S.C.	KW
-	FC/MC/PC/UC18	1.00	1.00	1.00
-	FC/MC/PC/UC24	1.00	1.00	1.00
-	FC/MC/PC/UC30	1.00	1.00	1.00
-	HC18	1.00	1.00	1.00
AHP24	-	1.00	1.00	1.00
AV24	-	1.00	1.03	0.91
F4FP024	-	1.00	1.00	1.00

Air Handler	Coil	T.C.	S.C.	KW
MV12B	FC/MC18B	1.00	1.03	0.91
MA08B	FC/MC18B	1.00	1.00	1.00
MV12B	FC/MC24B	1.00	1.03	0.91
MA08B	FC/MC24B	1.00	1.00	1.00
MV12B	FC/MC30B	1.00	1.03	0.91
MA08B	FC/MC30B	1.00	1.00	1.00

Continued on Page 29.

Variable Speed Furnace	Coil	T.C.	S.C.	KW
(F,L)C8V*A12	FC/MC/PC18A	1.00	1.03	0.91
FC9V*A12	FC/MC/PC18A	1.00	1.03	0.91
FC9(C,V)*B12	FC/MC/PC18B	1.00	1.03	0.91
(F,L)C8V*A12	FC/MC/PC24A	1.00	1.03	0.91
FC9V*A12	FC/MC/PC24A	1.00	1.03	0.91
FC9(C,V)*B12	FC/MC/PC24B	1.00	1.03	0.91
(F,L)C8V*A12	FC/MC/PC30A	1.00	1.03	0.91
FC9V*A12	FC/MC/PC30A	1.00	1.03	0.91
FC9(C,V)*B12	FC/MC/PC30B	1.00	1.03	0.91
(F,L)C8V*A12	HC18	1.00	1.03	0.91
FC9V*A12	HC18	1.00	1.03	0.91
C*(8,L)C*A12	FC/MC/PC18A	1.00	1.03	0.93
C*(8,L)C*B12	FC/MC/PC18B	1.00	1.00	0.92
C*9C*B12	FC/MC/PC18B	1.00	1.01	0.92
C*(8,L)C*A12	FC/MC/PC24A	1.00	1.04	0.95
C*(8,L)C*B12	FC/MC/PC24B	1.00	1.00	0.92
C*9C*B12	FC/MC/PC24B	1.00	1.04	0.94
C*(8,L)C*A12	FC/MC/PC30A	1.00	1.04	0.95
C*(8,L)C*B12	FC/MC/PC30B	1.00	1.00	0.92
C*9C*B12	FC/MC/PC30B	1.00	1.04	0.94
C*(8,L)C*A12	HC18	1.00	1.02	0.93
C*(8,L)C*A12	HD24	1.00	1.02	0.95
C*(8,L)C*B12	HD24	1.00	1.00	0.92
C*9C*B12	HD24	1.00	1.02	0.94

Variable Speed Furnace	Coil	T.C.	S.C.	KW
C*(8,L)C*A12	UC18A	1.00	1.02	0.94
C*(8,L)C*B12	UC18B	1.00	1.00	0.93
C*9C*B12	UC18B	1.00	1.02	0.93
C*(8,L)C*A12	UC24A	1.00	1.05	0.95
C*(8,L)C*B12	UC24B	1.00	1.00	0.92
C*9C*B12	UC24B	1.00	1.05	0.94
C*(8,L)C*A12	UC30A	1.00	1.05	0.95
C*(8,L)C*B12	UC30B	1.00	1.00	0.92
C*9C*B12	UC30B	1.00	1.05	0.94
G*9V*A12	FC/MC/PC18A	1.00	1.03	0.95
G*9V*B12	FC/MC/PC18B	1.00	1.01	0.92
G*9V*A12	FC/MC/PC24A	1.00	1.02	0.95
G*9V*B12	FC/MC/PC24B	1.00	1.04	0.94
G*9V*A12	FC/MC/PC30A	1.00	1.02	0.95
G*9V*B12	FC/MC/PC30B	1.00	1.04	0.94
G*9V*A12	HC18	1.00	1.03	0.95
G*9V*A12	HD24	1.00	1.02	0.96
G*9V*B12	HD24	1.00	1.02	0.94
G*9V*A12	UC18A	1.00	1.02	0.95
G*9V*B12	UC18B	1.00	1.02	0.93
G*9V*A12	UC24A	1.00	1.03	0.96
G*9V*B12	UC24B	1.00	1.05	0.94
G*9V*A12	UC30A	1.00	1.03	0.96
G*9V*B12	UC30B	1.00	1.05	0.94

COOLING PERFORMANCE DATA																
CONDENSING UNIT MODEL NO.		CHJD24S21S1														
INDOOR COIL MODEL NO.		AHP24														
CONDENSING ENTERING AIR TEMPERATURE	IDCFM	600					800					1000				
	ID DB (°F)	80	80	75	80	80	80	80	75	80	80	80	80	75	80	80
	ID WB (°F)	57	62	62	67	72	57	62	62	67	72	57	62	62	67	72
65	T.C.	20.3	23.5	23.6	26.0	28.3	22.8	24.8	24.6	27.1	29.2	25.3	26.1	25.7	28.3	30.2
	S.C.	17.2	17.2	17.7	17.6	15.6	17.2	17.2	17.5	17.4	16.6	17.2	17.2	17.2	17.2	17.7
	KW	1.5	1.5	1.5	1.5	1.5	1.5	1.5	1.5	1.5	1.5	1.5	1.5	1.5	1.5	1.5
75	T.C.	19.9	22.3	22.3	24.7	26.8	22.1	23.5	23.3	25.8	27.7	24.2	24.6	24.3	26.8	28.6
	S.C.	17.2	17.2	17.2	17.2	14.9	17.2	17.2	17.2	17.2	15.9	17.2	17.2	17.2	17.2	16.9
	KW	1.6	1.6	1.6	1.6	1.6	1.6	1.6	1.6	1.6	1.6	1.6	1.6	1.6	1.6	1.6
85	T.C.	19.5	21.1	21.0	23.5	25.4	21.3	22.2	22.0	24.4	26.2	23.2	23.2	22.9	25.3	27.1
	S.C.	17.2	17.2	16.8	16.9	14.3	17.2	17.2	17.0	17.1	15.2	17.2	17.2	17.2	17.2	16.1
	KW	1.7	1.7	1.7	1.7	1.8	1.7	1.7	1.7	1.8	1.8	1.7	1.7	1.7	1.8	1.8
95	T.C.	19.0	20.0	19.8	22.2	23.9	20.6	20.8	20.6	23.0	24.7	22.1	21.7	21.5	23.8	25.5
	S.C.	17.2	17.2	16.4	16.6	13.6	17.2	17.2	16.8	16.9	14.4	17.2	17.2	17.2	17.2	15.3
	KW	1.8	1.8	1.8	1.8	1.9	1.8	1.8	1.8	1.9	1.9	1.9	1.8	1.8	1.9	2.0
105	T.C.	17.9	18.6	18.4	20.6	22.3	19.3	19.5	19.0	21.3	22.9	20.7	20.4	19.7	22.0	23.5
	S.C.	17.2	17.2	15.7	15.8	12.8	17.2	17.2	16.5	16.5	13.7	17.2	17.2	17.2	17.2	14.5
	KW	1.9	1.9	1.9	2.0	2.1	2.0	2.0	1.9	2.0	2.1	2.0	2.0	2.0	2.1	2.1
115	T.C.	16.8	17.1	16.9	18.9	20.7	18.1	18.2	17.5	19.6	21.1	19.3	19.2	18.0	20.3	21.5
	S.C.	16.8	17.1	15.0	15.1	12.1	17.2	17.2	16.1	16.2	12.9	17.2	17.2	17.2	17.2	13.8
	KW	2.0	2.0	2.0	2.1	2.2	2.1	2.1	2.1	2.2	2.3	2.2	2.2	2.1	2.2	2.3
125	T.C.	15.7	15.7	15.5	17.3	19.2	16.8	16.8	15.9	17.9	19.4	17.9	17.9	16.3	18.5	19.6
	S.C.	15.7	15.7	14.3	14.4	11.3	16.8	16.8	15.8	15.8	12.2	17.2	17.2	16.3	17.2	13.0
	KW	2.2	2.1	2.1	2.3	2.4	2.3	2.2	2.2	2.3	2.5	2.3	2.3	2.2	2.4	2.5

NOTE: ALL CAPACITIES INCLUDE INDOOR FAN HEAT AT 1250 BTUH/1000 CFM.

Multipliers for determining the performance with other indoor sections.

NOTE: For dry bulb temperatures different than those listed (between 73-87 F), sensible capacity increases by 1060 BTUH per 1000 CFM per degree above the listed temperature and decreases by 1060 BTUH per 1000 CFM per degree below the listed temperature.

Air Handler	Coil	T.C.	S.C.	KW
–	FC/MC/PC/UC24	1.00	1.00	1.00
–	FC/MC/PC/UC30	1.00	1.00	1.00
–	FC/MC/PC/UC32	1.00	1.00	1.00
–	FC/MC/PC/UC35	1.00	1.00	1.00
–	HC30	1.00	1.00	1.00
–	HC36	1.00	1.00	1.00
–	HD24	1.00	1.00	1.00
–	MH24S	1.00	1.00	1.00
–	MH30S	1.00	1.00	1.00
AHP30	–	1.00	1.00	1.00

Air Handler	Coil	T.C.	S.C.	KW
AV24	–	1.02	1.03	0.93
F4FP030	–	1.00	1.00	1.00
MV12B	FC/MC24B	1.01	1.02	0.92
MA08B	FC/MC24B	1.00	1.00	1.00
MV12B	FC/MC30B	1.01	1.02	0.92
MA08B	FC/MC30B	1.00	1.00	1.00
MV12B	FC/MC35B	1.02	1.02	0.93
MA08B	FC/MC35B	1.00	1.00	1.00

Continued on Page 31.

Variable Speed Furnace	Coil	T.C.	S.C.	KW
(F,L)C8V*A12	FC/MC/PC24A	1.01	1.02	0.92
FC9V*A12	FC/MC/PC24A	1.01	1.02	0.92
FC9(C,V)*B12	FC/MC/PC24B	1.01	1.02	0.92
(F,L)C8V*A12	FC/MC/PC30A	1.01	1.02	0.92
FC9V*A12	FC/MC/PC30A	1.01	1.02	0.92
FC9(C,V)*B12	FC/MC/PC30B	1.01	1.02	0.92
(F,L)C8V*A12	FC/MC/PC32A	1.01	1.02	0.92
FC9V*A12	FC/MC/PC32A	1.01	1.02	0.92
FC9(C,V)*B12	FC/MC/PC35B	1.01	1.02	0.92
(F,L)C8V*A12	HC30	1.01	1.02	0.92
FC9V*A12	HC30	1.01	1.02	0.92
FC9(C,V)*B12	HC36	1.01	1.02	0.92
C*(8,L)C*A12	FC/MC/PC24A	1.02	1.02	0.92
C*(8,L)C*B12	FC/MC/PC24B	1.02	1.02	0.91
C*9C*B12	FC/MC/PC24B	1.02	1.02	0.92
C*(8,L)C*A12	FC/MC/PC30A	1.02	1.02	0.92
C*(8,L)C*B12	FC/MC/PC30B	1.02	1.02	0.91
C*9C*B12	FC/MC/PC30B	1.02	1.02	0.92
C*(8,L)C*A12	FC/MC/PC32A	1.02	1.01	0.93
C*(8,L)C*B12	FC/MC/PC35B	1.03	1.02	0.92
C*9C*B12	FC/MC/PC35B	1.02	1.03	0.94
C*(8,L)C*A12	FC/MC/PC36A	1.02	1.02	0.92
C*(8,L)C*B12	FC/MC/PC36B	1.02	1.03	0.91
C*9C*B12	FC/MC/PC36B	1.02	1.03	0.92
C*(8,L)C*A12	FC/MC/PC37A	1.04	1.05	0.94
C*(8,L)C*B12	FC/MC/PC43B	1.03	1.03	0.92
C*9C*B12	FC/MC/PC43B	1.04	1.05	0.93
C*(8,L)C*A12	HC30	1.01	0.99	0.93
C*(8,L)C*B12	HC36	1.02	1.01	0.92
C*9C*B12	HC36	1.02	1.03	0.94
C*(8,L)C*A12	HD36	1.00	0.98	0.92
C*(8,L)C*B12	HD36	1.00	0.96	0.91
C*(8,L)C*C16	HD36	1.02	1.02	0.91
C*(8,L)C*C20	HD36	1.00	0.96	0.89

Variable Speed Furnace	Coil	T.C.	S.C.	KW
C*9C*B12	HD36	1.00	0.98	0.92
C*9C*C16	HD36	1.01	0.97	0.90
C*9C*C20	HD36	1.00	0.96	0.90
C*(8,L)C*A12	UC24A	1.03	1.03	0.92
C*(8,L)C*B12	UC24B	1.03	1.03	0.91
C*9C*B12	UC24B	1.03	1.02	0.92
C*(8,L)C*A12	UC30A	1.02	1.02	0.92
C*(8,L)C*B12	UC30B	1.03	1.03	0.91
C*9C*B12	UC30B	1.02	1.02	0.93
C*(8,L)C*A12	UC36A	1.02	1.02	0.92
C*(8,L)C*B12	UC36B	1.02	1.03	0.91
C*9C*B12	UC36B	1.02	1.02	0.92
G*9V*A12	FC/MC/PC24A	1.01	1.01	0.94
G*9V*B12	FC/MC/PC24B	1.02	1.02	0.92
G*9V*A12	FC/MC/PC30A	1.01	1.01	0.94
G*9V*B12	FC/MC/PC30B	1.02	1.02	0.92
G*9V*A12	FC/MC/PC32A	1.01	1.01	0.97
G*9V*B12	FC/MC/PC35B	1.02	1.03	0.94
G*9V*A12	FC/MC/PC36A	1.01	1.02	0.94
G*9V*B12	FC/MC/PC36B	1.02	1.03	0.92
G*9V*A12	FC/MC/PC37A	1.03	1.04	0.96
G*9V*B12	FC/MC/PC43B	1.04	1.05	0.93
G*9V*A12	HC30	1.01	1.01	0.94
G*9V*B12	HC36	1.02	1.03	0.94
G*9V*A12	HD36	1.00	0.97	0.93
G*9V*B12	HD36	1.00	0.98	0.92
G*9V*C16	HD36	1.01	0.97	0.90
G*9V*C20	HD36	1.00	0.96	0.90
G*9V*A12	UC24A	1.01	1.01	0.94
G*9V*B12	UC24B	1.03	1.02	0.92
G*9V*A12	UC30A	1.01	1.01	0.94
G*9V*B12	UC30B	1.02	1.02	0.93
G*9V*A12	UC36A	1.01	1.01	0.94
G*9V*B12	UC36B	1.02	1.02	0.92

COOLING PERFORMANCE DATA																
CONDENSING UNIT MODEL NO.		CHJD30S21S1														
INDOOR COIL MODEL NO.		AHP30														
CONDENSING ENTERING AIR TEMPERATURE	IDCFM	800					1000					1200				
	ID DB (°F)	80	80	75	80	80	80	80	75	80	80	80	80	75	80	80
	ID WB (°F)	57	62	62	67	72	57	62	62	67	72	57	62	62	67	72
65	T.C.	25.7	27.6	26.2	29.0	32.9	27.1	30.3	28.1	31.3	32.9	28.5	32.9	30.0	33.5	33.0
	S.C.	24.2	24.2	20.1	20.5	20.0	24.2	24.2	21.8	22.4	20.2	24.2	24.2	23.5	24.4	20.3
	KW	1.5	1.6	1.5	1.6	1.7	1.6	1.6	1.6	1.6	1.7	1.6	1.7	1.6	1.7	1.7
75	T.C.	25.2	27.4	26.0	29.2	31.2	26.4	29.1	27.3	30.3	31.8	27.6	30.8	28.5	31.5	32.4
	S.C.	24.2	24.2	20.3	21.1	18.9	24.2	24.2	21.6	22.1	19.3	24.2	24.2	22.9	23.1	19.6
	KW	1.7	1.7	1.7	1.8	1.8	1.7	1.8	1.7	1.8	1.8	1.7	1.8	1.8	1.8	1.8
85	T.C.	24.7	27.3	25.9	29.4	29.6	25.7	28.0	26.5	29.4	30.7	26.7	28.7	27.1	29.4	31.9
	S.C.	24.2	24.2	20.6	21.6	17.8	24.2	24.2	21.4	21.7	18.4	24.2	24.2	22.2	21.8	18.9
	KW	1.9	1.9	1.9	2.0	2.0	1.9	1.9	1.9	2.0	2.0	1.9	1.9	1.9	2.0	2.0
95	T.C.	24.2	27.1	25.7	29.7	27.9	25.0	26.9	25.7	28.5	29.6	25.8	26.6	25.6	27.4	31.4
	S.C.	24.2	24.2	20.8	22.2	16.7	24.2	24.2	21.2	21.3	17.5	24.2	24.2	21.6	20.5	18.2
	KW	2.0	2.1	2.1	2.1	2.1	2.1	2.1	2.1	2.1	2.1	2.1	2.1	2.1	2.1	2.2
105	T.C.	23.4	25.3	24.5	27.9	26.9	24.2	25.6	24.6	27.2	28.2	25.0	25.9	24.7	26.6	29.4
	S.C.	23.4	24.1	20.6	21.5	16.1	24.2	24.1	21.5	21.6	16.7	24.2	24.2	22.4	21.7	17.3
	KW	2.2	2.2	2.2	2.3	2.3	2.2	2.3	2.2	2.3	2.3	2.2	2.3	2.3	2.3	2.3
115	T.C.	22.6	23.4	23.2	26.1	26.0	23.4	24.3	23.5	25.9	26.7	24.3	25.2	23.9	25.8	27.4
	S.C.	22.6	23.4	20.3	20.7	15.5	23.4	24.1	21.8	21.8	15.9	24.2	24.2	23.3	22.9	16.3
	KW	2.3	2.4	2.4	2.5	2.4	2.4	2.4	2.4	2.5	2.5	2.4	2.4	2.4	2.5	2.5
125	T.C.	21.8	21.6	22.0	24.3	25.0	22.6	23.0	22.5	24.7	25.2	23.5	24.4	23.0	25.0	25.4
	S.C.	21.8	21.6	20.0	20.0	14.9	22.6	23.0	22.1	22.1	15.1	23.5	24.2	23.0	24.2	15.3
	KW	2.5	2.5	2.5	2.6	2.6	2.5	2.6	2.5	2.6	2.6	2.6	2.6	2.6	2.6	2.7

NOTE: ALL CAPACITIES INCLUDE INDOOR FAN HEAT AT 1250 BTUH/1000 CFM.

Multipliers for determining the performance with other indoor sections.

NOTE: For dry bulb temperatures different than those listed (between 73-87 F), sensible capacity increases by 1060 BTUH per 1000 CFM per degree above the listed temperature and decreases by 1060 BTUH per 1000 CFM per degree below the listed temperature.

Air Handler	Coil	T.C.	S.C.	KW
-	FC/MC/PC/UC32	1.00	1.00	1.00
-	FC/MC/PC/UC35	1.00	1.00	1.00
-	FC/MC/PC/UC37	1.00	1.00	1.00
-	FC/MC/PC/UC43	1.00	1.00	1.00
-	HC36	1.00	1.00	1.00
-	HC42	1.00	1.00	1.00
-	HD36	1.00	1.00	1.00
-	MH24S	1.00	1.00	1.00
-	MH30S	1.00	1.00	1.00
AHP36	-	1.00	1.00	1.00

Air Handler	Coil	T.C.	S.C.	KW
AV36	-	1.02	1.03	0.93
F4FP040	-	1.00	1.00	1.00
MV12B	FC/MC35B	1.02	1.02	0.93
MV16C	FC/MC35C	1.02	1.03	0.93
MA12B	FC/MC35B	1.00	1.00	1.00
MV12B	FC/MC43B	1.02	1.02	0.93
MV16C	FC/MC43C	1.02	1.03	0.93
MA12B	FC/MC43B	1.00	1.00	1.00

Continued on Page 33.

Variable Speed Furnace	Coil	T.C.	S.C.	KW
(F,L)C8V*A12	FC/MC/PC32A	1.01	1.01	0.92
FC9V*A12	FC/MC/PC32A	1.01	1.01	0.92
(F,L)C8V*B16	FC/MC/PC35B	1.02	1.03	0.93
(F,L)C8V*C16	FC/MC/PC35C	1.02	1.03	0.93
(F,L)C8V*C20	FC/MC/PC35C	1.01	1.01	0.92
FC9(C,V)*B12	FC/MC/PC35B	1.02	1.01	0.93
FC9(C,V)*C16	FC/MC/PC35C	1.02	1.02	0.93
(F,L)C8V*A12	FC/MC/PC38A	1.01	1.01	0.92
FC9V*A12	FC/MC/PC38A	1.01	1.01	0.92
(F,L)C8V*B16	FC/MC/PC43B	1.02	1.03	0.93
(F,L)C8V*C16	FC/MC/PC43C	1.02	1.03	0.93
(F,L)C8V*C20	FC/MC/PC43C	1.01	1.01	0.92
FC9(C,V)*B12	FC/MC/PC43B	1.02	1.01	0.93
FC9(C,V)*C16	FC/MC/PC43C	1.02	1.02	0.93
(F,L)C8V*B16	HC36	1.02	1.03	0.93
FC9(C,V)*B12	HC36	1.02	1.01	0.93
(F,L)C8V*C16	HC42	1.02	1.03	0.93
(F,L)C8V*C20	HC42	1.01	1.01	0.92
FC9(C,V)*C16	HC42	1.02	1.02	0.93
C*(8,L)C*A12	FC/MC/PC32A	1.00	1.01	0.99
C*(8,L)C*B12	FC/MC/PC35B	1.01	1.02	0.95
C*9C*B12	FC/MC/PC35B	1.01	1.02	0.97
C*(8,L)C*C16	FC/MC/PC35C	1.01	1.02	0.93
C*(8,L)C*C20	FC/MC/PC35C	1.02	1.05	0.94
C*9C*C16	FC/MC/PC35C	1.01	1.02	0.93
C*9C*C20	FC/MC/PC35C	1.01	1.02	0.93
C*(8,L)C*A12	FC/MC/PC36A	0.99	0.99	0.95
C*(8,L)C*B12	FC/MC/PC36B	0.99	0.99	0.93
C*9C*B12	FC/MC/PC36B	0.99	0.99	0.94
C*(8,L)C*C16	FC/MC/PC36C	1.00	1.00	0.93
C*(8,L)C*C20	FC/MC/PC36C	1.00	1.01	0.92
C*9C*C16	FC/MC/PC36C	1.00	1.00	0.93
C*9C*C20	FC/MC/PC36C	0.99	1.00	0.93
C*(8,L)C*A12	FC/MC/PC37A	1.01	1.01	0.97
C*(8,L)C*B12	FC/MC/PC43B	1.02	1.02	0.94
C*9C*B12	FC/MC/PC43B	1.01	1.02	0.96
C*(8,L)C*C16	FC/MC/PC43C	1.02	1.03	0.92
C*(8,L)C*C20	FC/MC/PC43C	1.03	1.04	0.92
C*9C*C16	FC/MC/PC43C	1.02	1.02	0.95
C*9C*C20	FC/MC/PC43C	1.02	1.03	0.93
C*(8,L)C*B12	HC36	1.00	1.00	0.95
C*9C*B12	HC36	1.01	1.02	0.97

Variable Speed Furnace	Coil	T.C.	S.C.	KW
C*(8,L)C*C16	HC42	1.02	1.03	0.92
C*(8,L)C*C20	HC42	1.02	1.03	0.92
C*9C*C16	HC42	1.02	1.02	0.95
C*9C*C20	HC42	1.02	1.03	0.93
C*(8,L)C*A12	HD36	0.97	0.95	0.95
C*(8,L)C*B12	HD36	0.98	0.96	0.93
C*(8,L)C*C16	HD36	0.98	0.96	0.92
C*(8,L)C*C20	HD36	0.99	0.99	0.92
C*9C*B12	HD36	0.98	0.96	0.94
C*9C*C16	HD36	0.98	0.96	0.92
C*9C*C20	HD36	0.98	0.96	0.93
C*(8,L)C*A12	UC36A	0.99	0.99	0.95
C*(8,L)C*B12	UC36B	0.99	0.99	0.93
C*9C*B12	UC36B	0.99	0.99	0.94
C*(8,L)C*C16	UC36C	0.99	1.00	0.93
C*(8,L)C*C20	UC36C	0.99	1.00	0.92
C*9C*C16	UC36C	0.99	1.00	0.93
C*9C*C20	UC36C	0.99	1.00	0.93
G*9V*A12	FC/MC/PC32A	1.00	1.00	0.96
G*9V*B12	FC/MC/PC35B	1.01	1.02	0.97
G*9V*C16	FC/MC/PC35C	1.01	1.02	0.93
G*9V*C20	FC/MC/PC35C	1.01	1.02	0.93
G*9V*A12	FC/MC/PC36A	0.98	0.98	0.95
G*9V*B12	FC/MC/PC36B	0.99	0.99	0.94
G*9V*C16	FC/MC/PC36C	1.00	1.00	0.93
G*9V*C20	FC/MC/PC36C	0.99	1.00	0.93
G*9V*A12	FC/MC/PC37A	1.01	1.02	0.97
G*9V*B12	FC/MC/PC43B	1.01	1.02	0.96
G*9V*C16	FC/MC/PC43C	1.02	1.02	0.95
G*9V*C20	FC/MC/PC43C	1.02	1.03	0.93
G*9V*B12	HC36	1.01	1.02	0.97
G*9V*C16	HC42	1.02	1.02	0.95
G*9V*C20	HC42	1.02	1.03	0.93
G*9V*A12	HD36	0.97	0.95	0.95
G*9V*B12	HD36	0.98	0.96	0.94
G*9V*C16	HD36	0.98	0.96	0.92
G*9V*C20	HD36	0.98	0.96	0.93
G*9V*A12	UC36A	0.99	0.98	0.95
G*9V*B12	UC36B	0.99	0.99	0.94
G*9V*C16	UC36C	0.99	1.00	0.93
G*9V*C20	UC36C	0.99	1.00	0.93

COOLING PERFORMANCE DATA																
CONDENSING UNIT MODEL NO.		CHJD36S21S1														
INDOOR COIL MODEL NO.		AHP36														
CONDENSING ENTERING AIR TEMPERATURE	IDCFM	1000					1200					1400				
	ID DB (°F)	80	80	75	80	80	80	80	75	80	80	80	80	75	80	80
	ID WB (°F)	57	62	62	67	72	57	62	62	67	72	57	62	62	67	72
65	T.C.	35.0	37.8	37.5	41.8	46.7	37.1	39.1	38.7	43.0	47.4	39.1	40.4	39.9	44.2	48.1
	S.C.	33.9	31.5	26.9	26.8	22.0	36.0	34.7	29.4	29.0	23.8	38.1	37.9	31.8	31.3	25.5
	KW	1.9	1.9	1.9	1.9	1.9	1.9	1.9	1.9	1.9	1.9	1.9	1.9	1.9	1.9	1.9
75	T.C.	33.5	35.8	35.6	39.6	44.3	35.4	37.0	36.8	40.7	45.2	37.4	38.2	37.9	41.8	46.0
	S.C.	32.4	30.5	26.0	26.0	21.2	34.4	33.5	28.4	28.2	22.9	36.4	36.5	30.8	30.5	24.6
	KW	2.1	2.1	2.1	2.1	2.1	2.1	2.1	2.1	2.1	2.1	2.1	2.1	2.1	2.1	2.2
85	T.C.	32.0	33.8	33.8	37.4	41.9	33.8	34.9	34.9	38.4	42.9	35.6	36.0	36.0	39.4	43.8
	S.C.	31.0	29.5	25.1	25.1	20.3	32.8	32.3	27.5	27.4	22.0	34.7	35.1	29.8	29.8	23.7
	KW	2.3	2.3	2.3	2.3	2.4	2.3	2.3	2.3	2.3	2.4	2.3	2.3	2.3	2.3	2.4
95	T.C.	30.5	31.8	31.9	35.1	39.6	32.1	32.8	33.0	36.1	40.6	33.8	33.8	34.1	37.0	41.7
	S.C.	29.5	28.4	24.3	24.2	19.5	31.2	31.1	26.6	26.6	21.2	33.0	33.7	28.8	29.0	22.8
	KW	2.4	2.5	2.5	2.5	2.6	2.5	2.5	2.5	2.5	2.6	2.5	2.5	2.5	2.5	2.6
105	T.C.	29.0	29.9	29.8	32.9	36.9	30.5	30.8	30.8	33.7	37.8	31.9	31.7	31.7	34.5	38.7
	S.C.	28.1	27.5	23.4	23.3	18.6	29.6	29.7	25.7	25.7	20.2	31.2	31.9	28.0	28.0	21.8
	KW	2.7	2.7	2.7	2.7	2.8	2.7	2.7	2.7	2.7	2.8	2.7	2.7	2.7	2.7	2.8
115	T.C.	27.7	28.0	27.9	30.7	34.2	28.9	28.9	28.6	31.3	35.0	30.1	29.8	29.3	32.0	35.8
	S.C.	26.8	26.6	22.6	22.4	17.7	28.1	28.4	24.9	24.7	19.2	29.4	30.2	27.1	27.0	20.8
	KW	2.9	2.9	2.8	2.9	3.0	2.9	2.9	2.9	3.0	3.0	3.0	2.9	2.9	3.0	3.1
125	T.C.	26.3	26.1	25.9	28.5	31.6	27.3	27.0	26.4	29.0	32.3	28.3	27.8	27.0	29.5	32.9
	S.C.	25.5	25.7	21.8	21.5	16.8	26.6	27.1	24.0	23.8	18.3	27.6	28.4	26.3	26.0	19.8
	KW	3.1	3.1	3.0	3.1	3.2	3.1	3.1	3.1	3.2	3.3	3.2	3.2	3.1	3.2	3.3

NOTE: ALL CAPACITIES INCLUDE INDOOR FAN HEAT AT 1250 BTUH/1000 CFM.

Multipliers for determining the performance with other indoor sections.

NOTE: For dry bulb temperatures different than those listed (between 73-87 F), sensible capacity increases by 1060 BTUH per 1000 CFM per degree above the listed temperature and decreases by 1060 BTUH per 1000 CFM per degree below the listed temperature.

Air Handler	Coil	T.C.	S.C.	KW
–	FC/MC/PC/UC37	1.00	1.00	1.00
–	FC/MC/PC/UC43	1.00	1.00	1.00
–	FC/MC/PC/UC48	1.00	1.00	1.00
–	FC/MC/PC/UC60	1.00	1.00	1.00
–	HC42	1.00	1.00	1.00
–	HC60	1.00	1.00	1.00
–	HD48	1.00	1.00	1.00
–	HD60	1.00	1.00	1.00
AHP42	–	1.00	1.00	1.00
AHP/SHP60	–	1.01	1.02	0.92
AV36	–	1.01	1.02	0.92
AV/SV48	–	1.01	1.02	0.92
F4FP045	–	1.00	1.00	1.00
F4FV060	–	1.01	1.02	0.92

Air Handler	Coil	T.C.	S.C.	KW
F5FP048	–	1.01	1.02	0.92
F5FP060	–	1.01	1.02	0.92
MV16C	FC/MC43C	1.02	1.03	0.93
MA12B	FC/MC43B	1.00	1.00	1.00
MV12B	FC/MC43B	1.01	1.02	0.92
MV16C	FC/MC48C	1.02	1.03	0.93
MV16C	FC60C	1.02	1.03	0.93
MV12D	FC/MC48D	1.02	1.03	0.93
MV12D	FC/MC60D	1.02	1.03	0.93
MA14D	FC/MC48D	1.00	1.00	1.00
MA14D	FC/MC60D	1.00	1.00	1.00
MV12D	FC/MC48D	1.01	1.03	0.92

Continued on Page 35.

Variable Speed Furnace	Coil	T.C.	S.C.	KW
(F,L)C8V*A12	FC/MC/PC38A	1.01	1.01	1.00
FC9V*A12	FC/MC/PC38A	1.00	1.00	1.00
(F,L)C8V*B16	FC/MC/PC43B	1.01	1.02	0.92
(F,L)C8V*C16	FC/MC/PC43C	1.01	1.02	0.92
(F,L)C8V*C20	FC/MC/PC43C	1.01	1.01	0.92
FC9(C,V)*B12	FC/MC/PC43B	1.01	1.01	0.92
FC9(C,V)*C16	FC/MC/PC43C	1.01	1.02	0.92
FC9(C,V)*C20	FC/MC/PC43C	1.01	1.02	0.92
(F,L)C8V*C16	FC/MC/PC48C	1.02	1.03	0.93
(F,L)C8V*C20	FC/MC/PC48C	1.01	1.01	0.92
FC9(C,V)*C16	FC/MC/PC48C	1.01	1.02	0.92
FC9(C,V)*C20	FC/MC/PC48C	1.01	1.02	0.92
FC9(C,V)*D20	FC/MC/PC48D	1.01	1.02	0.92
(F,L)C8V*C16	HC42	1.02	1.02	0.93
(F,L)C8V*C20	HC42	1.01	1.01	0.92
FC9(C,V)*C16	HC42	1.01	1.02	0.92
FC9(C,V)*C20	HC42	1.01	1.02	0.92
C*(8,L)C*A12	FC/MC/PC37A	0.99	0.93	0.94
C*(8,L)C*B12	FC/MC/PC43B	1.02	1.02	0.98
C*9C*B12	FC/MC/PC43B	1.02	1.02	0.98
C*(8,L)C*C16	FC/MC/PC43C	1.03	1.03	0.95
C*(8,L)C*C20	FC/MC/PC43C	1.03	1.03	0.94
C*9C*C16	FC/MC/PC43C	1.02	1.03	0.97
C*9C*C20	FC/MC/PC43C	1.02	1.03	0.95
C*(8,L)C*C16	FC/MC/PC48C	1.02	1.04	0.94
C*(8,L)C*C20	FC/MC/PC48C	1.02	1.05	0.93
C*9C*C16	FC/MC/PC48C	1.02	1.04	0.95
C*9C*C20	FC/MC/PC48C	1.03	1.08	0.98

Variable Speed Furnace	Coil	T.C.	S.C.	KW
C*(8,L)C*C16	HC42	1.02	1.03	0.95
C*(8,L)C*C20	HC42	1.02	1.03	0.94
C*9C*C16	HC42	1.01	1.02	0.97
C*9C*C20	HC42	1.02	1.03	0.95
C*(8,L)C*B12	HD48	1.02	1.01	0.96
C*(8,L)C*C16	HD48	1.03	1.03	0.94
C*(8,L)C*C20	HD48	1.03	1.03	0.93
C*9C*B12	HD48	1.01	1.01	0.97
C*9C*C16	HD48	1.02	1.02	0.95
C*9C*C20	HD48	1.03	1.06	0.98
C*(8,L)C*C16	UC48C	1.03	1.04	0.94
C*(8,L)C*C20	UC48C	1.03	1.04	0.93
C*9C*C16	UC48C	1.03	1.04	0.95
C*9C*C20	UC48C	1.03	1.08	0.98
G*9V*A12	FC/MC/PC37A	1.01	0.97	0.98
G*9V*B12	FC/MC/PC43B	1.02	1.02	0.98
G*9V*C16	FC/MC/PC43C	1.02	1.03	0.97
G*9V*C20	FC/MC/PC43C	1.02	1.03	0.95
G*9V*C16	FC/MC/PC48C	1.02	1.04	0.95
G*9V*C20	FC/MC/PC48C	1.03	1.08	0.98
G*9V*C16	HC42	1.01	1.02	0.97
G*9V*C20	HC42	1.02	1.03	0.95
G*9V*B12	HD48	1.01	1.01	0.97
G*9V*C16	HD48	1.02	1.02	0.95
G*9V*C20	HD48	1.03	1.06	0.98
G*9V*C16	UC48C	1.03	1.04	0.95
G*9V*C20	UC48C	1.03	1.08	0.98

COOLING PERFORMANCE DATA																
CONDENSING UNIT MODEL NO.		CHJD42S21S1														
INDOOR COIL MODEL NO.		AHP42														
CONDENSING ENTERING AIR TEMPERATURE	IDCFM	1200					1400					1600				
	ID DB (°F)	80	80	75	80	80	80	80	75	80	80	80	80	75	80	80
	ID WB (°F)	57	62	62	67	72	57	62	62	67	72	57	62	62	67	72
65	T.C.	38.3	43.6	41.6	46.5	49.4	40.5	44.8	42.8	47.6	50.2	42.7	46.1	44.0	48.7	50.9
	S.C.	38.3	36.8	30.3	31.3	24.1	40.5	39.8	32.7	33.6	25.5	42.7	42.9	35.1	35.8	27.0
	KW	2.4	2.4	2.4	2.4	2.4	2.4	2.4	2.4	2.4	2.5	2.4	2.4	2.4	2.4	2.5
75	T.C.	37.0	41.4	39.7	44.3	47.0	39.0	42.8	40.8	45.3	47.4	41.0	44.3	41.9	46.3	47.9
	S.C.	37.0	35.8	29.5	30.3	23.7	39.0	38.7	31.9	32.6	25.2	41.0	41.5	34.3	34.9	26.7
	KW	2.6	2.6	2.6	2.6	2.7	2.6	2.6	2.6	2.7	2.7	2.6	2.6	2.6	2.7	2.7
85	T.C.	35.6	39.3	37.9	42.1	44.6	37.4	40.9	38.8	43.1	44.7	39.3	42.4	39.7	44.0	44.8
	S.C.	35.6	34.8	28.8	29.3	23.4	37.4	37.5	31.1	31.6	24.9	39.3	40.1	33.4	34.0	26.5
	KW	2.8	2.8	2.8	2.9	2.9	2.8	2.9	2.8	2.9	2.9	2.9	2.9	2.8	2.9	3.0
95	T.C.	34.2	37.2	36.0	40.0	42.2	35.9	38.9	36.8	41.0	42.0	37.6	40.5	37.6	41.6	41.8
	S.C.	34.2	33.8	28.0	28.3	23.0	35.9	36.3	30.3	30.8	24.6	37.6	38.8	32.6	33.0	26.3
	KW	3.0	3.1	3.0	3.1	3.2	3.1	3.1	3.0	3.1	3.2	3.1	3.1	3.1	3.2	3.2
105	T.C.	32.4	35.2	33.6	37.3	39.4	34.2	36.8	34.3	38.0	39.4	36.1	38.4	35.1	38.7	39.4
	S.C.	32.4	32.2	26.7	27.1	21.7	34.2	34.3	28.9	29.4	23.3	35.8	36.4	31.2	31.6	24.9
	KW	3.3	3.3	3.2	3.3	3.4	3.3	3.3	3.3	3.4	3.5	3.4	3.4	3.3	3.4	3.5
115	T.C.	30.6	33.2	31.2	34.7	36.7	32.6	34.7	32.0	35.4	36.9	34.6	36.3	32.7	36.0	37.1
	S.C.	30.6	30.6	25.5	26.0	20.5	32.3	32.3	27.6	28.1	22.0	33.7	34.0	29.8	30.2	23.6
	KW	3.5	3.5	3.5	3.6	3.7	3.5	3.6	3.5	3.6	3.7	3.6	3.6	3.5	3.6	3.7
125	T.C.	28.8	31.2	28.8	32.1	33.9	31.0	32.7	29.6	32.7	34.3	33.1	34.2	30.3	33.3	34.7
	S.C.	28.8	29.1	24.3	24.8	19.2	30.3	30.4	26.3	26.8	20.7	31.7	31.7	28.4	28.9	22.2
	KW	3.7	3.7	3.7	3.8	4.0	3.8	3.8	3.7	3.8	4.0	3.8	3.8	3.7	3.9	4.0

NOTE: ALL CAPACITIES INCLUDE INDOOR FAN HEAT AT 1250 BTUH/1000 CFM.

Multipliers for determining the performance with other indoor sections.

NOTE: For dry bulb temperatures different than those listed (between 73-87 F), sensible capacity increases by 1060 BTUH per 1000 CFM per degree above the listed temperature and decreases by 1060 BTUH per 1000 CFM per degree below the listed temperature.

Air Handler	Coil	T.C.	S.C.	KW
-	FC/MC/PC/UC60	1.00	1.00	1.00
-	HC60	1.00	1.00	1.00
-	HD60	1.00	1.00	1.00
AHP/SHP48	-	1.00	1.00	1.00
AHP/SHP60	-	1.01	1.02	1.00
AV/SV48	-	1.01	1.02	1.00
AV/SV60	-	1.01	1.02	1.00
F4FV060	-	1.01	1.02	1.00
F5FP045	-	1.00	1.00	1.00
F5FP048	-	1.01	1.02	1.00

Air Handler	Coil	T.C.	S.C.	KW
F5FP060	-	1.01	1.02	1.00
MV16C	FC/MC48C	1.01	1.02	1.00
MV16C	FC/MC60C	1.01	1.02	1.00
MV20D	FC/MC48D	1.01	1.02	1.00
MA14D	FC/MC48D	1.00	1.00	1.00
MA16C	FC/MC48C	1.00	1.00	1.00
MV20D	FC/MC60D	1.01	1.02	1.00
MA14D	FC/MC60D	1.00	1.00	1.00
MA16C	FC60C	1.00	1.00	1.00

Continued on Page 37.

Variable Speed Furnace	Coil	T.C.	S.C.	KW
(F,L)C8V*C16	FC/MC/PC48C	0.98	1.01	0.98
(F,L)C8V*C20	FC/MC/PC48C	1.01	1.01	1.00
FC9(C,V)*C16	FC/MC/PC48C	1.00	1.00	1.00
FC9(C,V)*C20	FC/MC/PC48C	0.98	1.01	0.98
FC9(C,V)*D20	FC/MC/PC48D	0.98	1.00	0.98
(F,L)C8V*C16	FC/PC60C	1.01	1.01	1.00
(F,L)C8V*C20	FC/PC60C	1.01	1.01	1.00
FC9(C,V)*C16	FC/PC60C	1.00	1.00	1.00
FC9(C,V)*C20	FC/PC60C	1.01	1.01	1.00
FC9(C,V)*D20	FC/MC/PC60D	0.98	1.00	0.98
C*(8,L)C*C16	FC/MC/PC48C	1.02	1.04	0.97
C*(8,L)C*C20	FC/MC/PC48C	1.02	1.04	0.96
C*9C*C16	FC/MC/PC48C	1.02	1.03	0.97
C*9C*C20	FC/MC/PC48C	1.01	1.03	0.98
C*9C*D20	FC/MC/PC48D	1.02	1.03	0.97
C*9C*D20	FC/MC/PC60D	1.00	1.03	0.96
C*(8,L)C*C16	FC/PC60C	1.00	1.03	0.96
C*(8,L)C*C20	FC/PC60C	1.00	1.03	0.95
C*9C*C16	FC/PC60C	0.99	1.02	0.98
C*9C*C20	FC/PC60C	0.99	1.02	0.97
C*(8,L)C*B12	HD48	0.97	0.96	0.95
C*(8,L)C*C16	HD48	1.00	1.00	0.94
C*(8,L)C*C20	HD48	1.00	1.00	0.93
C*9C*B12	HD48	0.93	0.89	0.91
C*9C*C16	HD48	0.99	1.00	0.95
C*9C*C20	HD48	0.99	0.99	0.95
C*9C*D20	HD48	0.99	1.00	0.94

Variable Speed Furnace	Coil	T.C.	S.C.	KW
C*(8,L)C*C16	UC48C	0.99	1.02	0.96
C*(8,L)C*C20	UC48C	0.99	1.02	0.95
C*9C*C16	UC48C	0.99	1.01	0.97
C*9C*C20	UC48C	0.99	1.01	0.97
C*9C*D20	UC48D	0.99	1.01	0.96
C*(8,L)C*C16	UC60C	0.98	1.01	0.95
C*(8,L)C*C20	UC60C	0.99	1.01	0.94
C*9C*C16	UC60C	0.97	1.00	0.98
C*9C*C20	UC60C	0.98	1.00	0.97
C*9C*D20	UC60D	0.98	1.01	0.96
G*9V*C16	FC/MC/PC48C	1.02	1.03	0.97
G*9V*C20	FC/MC/PC48C	1.01	1.03	0.98
G*9V*D20	FC/MC/PC48D	1.02	1.03	0.97
G*9V*D20	FC/MC/PC60D	1.00	1.03	0.96
G*9V*C16	FC/PC60C	0.99	1.02	0.98
G*9V*C20	FC/PC60C	0.99	1.02	0.97
G*9V*B12	HD48	0.93	0.89	0.91
G*9V*C16	HD48	0.99	1.00	0.95
G*9V*C20	HD48	0.99	0.99	0.95
G*9V*D20	HD48	0.99	1.00	0.94
G*9V*C16	UC48C	0.99	1.01	0.97
G*9V*C20	UC48C	0.99	1.01	0.97
G*9V*D20	UC48D	0.99	1.01	0.96
G*9V*C16	UC60C	0.97	1.00	0.98
G*9V*C20	UC60C	0.98	1.00	0.97
G*9V*D20	UC60D	0.98	1.01	0.96

COOLING PERFORMANCE DATA																
CONDENSING UNIT MODEL NO.		CHJD48S21S1														
INDOOR COIL MODEL NO.		FC/MC/PC/UC48														
CONDENSING ENTERING AIR TEMPERATURE	IDCFM	1400					1600					1800				
	ID DB (°F)	80	80	75	80	80	80	80	75	80	80	80	80	75	80	80
	ID WB (°F)	57	62	62	67	72	57	62	62	67	72	57	62	62	67	72
65	T.C.	43.6	47.2	46.7	50.8	55.5	46.0	48.7	47.3	51.8	55.7	48.3	50.3	47.9	52.8	55.9
	S.C.	43.2	41.1	32.8	33.4	26.3	44.9	43.8	35.5	35.5	27.2	46.6	46.5	38.2	37.7	28.2
	KW	2.4	2.4	2.4	2.5	2.5	2.4	2.4	2.4	2.5	2.5	2.4	2.4	2.4	2.5	2.5
75	T.C.	42.1	45.4	44.4	48.8	52.7	44.3	46.8	45.1	49.7	53.1	46.5	48.2	45.8	50.7	53.5
	S.C.	41.6	40.0	32.4	32.6	25.2	43.3	42.5	34.7	34.7	26.2	44.9	44.9	37.1	36.8	27.2
	KW	2.8	2.8	2.8	2.8	2.9	2.8	2.8	2.8	2.8	2.9	2.8	2.8	2.8	2.8	2.9
85	T.C.	40.5	43.7	42.1	46.8	50.0	42.6	44.9	42.9	47.7	50.5	44.8	46.1	43.8	48.5	51.1
	S.C.	40.1	39.0	31.9	31.8	24.1	41.7	41.2	34.0	33.8	25.2	43.3	43.4	36.0	35.8	26.3
	KW	3.1	3.1	3.1	3.2	3.2	3.1	3.1	3.1	3.2	3.2	3.1	3.2	3.1	3.2	3.2
95	T.C.	39.0	41.9	39.9	44.8	47.2	41.0	42.9	40.8	45.6	47.9	43.0	44.0	41.7	46.4	48.6
	S.C.	38.5	38.0	31.5	31.0	23.0	40.0	39.9	33.2	32.9	24.2	41.6	41.8	34.9	34.9	25.3
	KW	3.5	3.5	3.5	3.5	3.6	3.5	3.5	3.5	3.5	3.6	3.5	3.5	3.5	3.5	3.6
105	T.C.	37.2	39.5	37.7	42.4	44.4	39.4	40.5	38.5	43.1	45.1	41.6	41.5	39.4	43.8	45.7
	S.C.	36.5	36.2	30.5	30.0	22.0	38.1	37.9	32.2	31.9	23.1	39.6	39.5	33.8	33.9	24.1
	KW	4.0	4.0	4.0	4.0	4.1	4.0	4.0	4.0	4.0	4.1	4.0	4.0	4.0	4.0	4.1
115	T.C.	35.5	37.3	35.6	40.1	41.8	37.9	38.1	36.4	40.7	42.3	40.2	39.0	37.1	41.4	42.8
	S.C.	34.6	34.5	29.5	29.1	21.1	36.2	35.9	31.1	31.0	22.0	37.8	37.3	32.8	32.9	22.9
	KW	4.5	4.5	4.5	4.5	4.6	4.5	4.5	4.5	4.5	4.6	4.5	4.5	4.5	4.5	4.6
125	T.C.	33.8	35.0	33.5	37.7	39.1	36.3	35.8	34.2	38.3	39.5	38.8	36.5	34.8	38.9	39.9
	S.C.	32.7	32.8	28.5	28.2	20.2	34.3	34.0	30.1	30.0	21.0	35.9	35.1	31.7	31.9	21.7
	KW	5.0	4.9	5.0	5.0	5.1	5.0	5.0	5.0	5.0	5.1	5.0	5.0	5.0	5.0	5.1

NOTE: ALL CAPACITIES INCLUDE INDOOR FAN HEAT AT 1250 BTUH/1000 CFM.

Multipliers for determining the performance with other indoor sections.

NOTE: For dry bulb temperatures different than those listed (between 73-87 F), sensible capacity increases by 1060 BTUH per 1000 CFM per degree above the listed temperature and decreases by 1060 BTUH per 1000 CFM per degree below the listed temperature.

Air Handler	Coil	T.C.	S.C.	KW
-	FC/MC/PC/UC60	1.02	1.00	1.01
-	FC/MC62	1.02	1.00	1.01
-	HC60	1.02	1.00	1.01
-	HD60	1.02	1.00	1.01
AHP/SHP60	-	1.03	1.01	1.02
AV/SV48	-	1.03	1.01	1.02
AV/SV60	-	1.03	1.01	1.02
F4FV060	-	1.03	1.01	1.02
F5FP060	-	1.03	1.01	1.02
MV16C	FC60C	1.00	1.00	0.98
MV20D	FC/MC60D	1.03	1.01	1.02
MV20D	FC/MC62D	1.04	1.02	1.00
MA16C	FC60C	1.02	1.00	1.01
MA20D	FC/MC60D	1.02	1.00	1.01
MV20D	FC/MC62D	1.03	1.01	1.02
MA20D	FC/MC62D	1.02	1.00	1.01

Variable Speed Furnace	Coil	T.C.	S.C.	KW
(F,L)C8V*C16	FC/PC60C	1.02	1.00	1.01
(F,L)C8V*C20	FC/PC60C	1.02	1.00	1.01
FC9(C,V)*C16	FC/PC60C	1.02	1.00	1.01
FC9(C,V)*C20	FC/PC60C	1.02	1.00	1.01
FC9(C,V)*D20	FC/MC/PC60D	1.02	1.00	1.01
(F,L)C8V*C20	FC/MC62D	1.02	1.00	1.01
FC9(C,V)*C20	FC/MC62D	1.02	1.00	1.01
FC9(C,V)*D20	FC/MC62D	1.02	1.00	1.01
C*9C*D20	FC/MC/PC60D	1.01	1.03	0.99

Variable Speed Furnace	Coil	T.C.	S.C.	KW
C*9C*D20	FC/MC62D	1.01	1.04	0.99
C*(8,L)C*C16	FC/PC60C	1.01	1.03	0.98
C*(8,L)C*C20	FC/PC60C	1.01	1.04	0.97
C*9C*C16	FC/PC60C	1.01	1.03	0.99
C*9C*C20	FC/PC60C	1.01	1.03	0.99
C*9C*D20	HC60	1.01	1.03	0.99
C*(8,L)C*C16	HD60	1.00	1.02	0.98
C*(8,L)C*C20	HD60	1.00	1.03	0.96
C*9C*C16	HD60	0.99	1.02	0.99
C*9C*C20	HD60	0.99	1.02	0.99
C*9C*D20	HD60	0.99	1.02	0.98
C*(8,L)C*C16	UC60C	1.00	1.01	0.98
C*(8,L)C*C20	UC60C	1.01	1.02	0.96
C*9C*C16	UC60C	1.00	1.01	0.99
C*9C*C20	UC60C	1.00	1.01	0.99
C*9C*D20	UC60D	1.00	1.01	0.98
G*9V*D20	FC/MC/PC60D	1.01	1.03	0.99
G*9V*D20	FC/MC62D	1.01	1.04	0.99
G*9V*C16	FC/PC60C	1.01	1.03	0.99
G*9V*C20	FC/PC60C	1.01	1.03	0.99
G*9V*D20	HC60	1.01	1.03	0.99
G*9V*C16	HD60	0.99	1.02	0.99
G*9V*C20	HD60	0.99	1.02	0.99
G*9V*D20	HD60	0.99	1.02	0.98
G*9V*C16	UC60C	1.00	1.01	0.99
G*9V*C20	UC60C	1.00	1.01	0.99
G*9V*D20	UC60D	1.00	1.01	0.98

COOLING PERFORMANCE DATA																
CONDENSING UNIT MODEL NO.		CHJD60S21S1														
INDOOR COIL MODEL NO.		FC/MC62														
CONDENSING ENTERING AIR TEMPERATURE	IDCFM	1600					1800					2000				
	ID DB (°F)	80	80	75	80	80	80	80	75	80	80	80	80	75	80	80
	ID WB (°F)	57	62	62	67	72	57	62	62	67	72	57	62	62	67	72
65	T.C.	54.0	55.2	55.2	60.7	64.4	56.4	57.0	56.5	62.3	65.6	58.7	58.7	57.7	63.9	66.7
	S.C.	49.8	47.0	36.8	39.6	29.4	52.1	50.2	40.6	42.1	30.8	54.4	53.5	44.3	44.6	32.2
	KW	2.9	2.9	3.0	3.0	3.1	3.0	2.9	3.0	3.0	3.1	3.0	2.9	3.0	3.0	3.1
75	T.C.	52.5	53.5	52.6	58.5	61.5	54.7	55.3	53.9	60.0	62.9	57.0	57.1	55.2	61.5	64.2
	S.C.	48.2	45.9	36.6	38.4	28.4	50.4	49.1	39.9	41.0	30.0	52.6	52.2	43.3	43.5	31.6
	KW	3.3	3.4	3.4	3.4	3.5	3.4	3.4	3.4	3.5	3.5	3.4	3.4	3.4	3.5	3.5
85	T.C.	50.9	51.8	50.1	56.2	58.7	53.0	53.7	51.4	57.6	60.2	55.2	55.5	52.7	59.1	61.7
	S.C.	46.7	44.9	36.3	37.3	27.5	48.7	47.9	39.3	39.8	29.2	50.8	50.9	42.3	42.4	31.0
	KW	3.7	3.8	3.8	3.9	3.9	3.8	3.8	3.8	3.9	4.0	3.8	3.8	3.9	3.9	4.0
95	T.C.	49.3	50.2	47.6	53.9	55.8	51.4	52.0	48.9	55.3	57.5	53.4	53.8	50.2	56.6	59.2
	S.C.	45.1	43.9	36.0	36.1	26.6	47.1	46.8	38.7	38.7	28.5	49.0	49.6	41.3	41.2	30.4
	KW	4.2	4.3	4.3	4.3	4.4	4.2	4.3	4.3	4.3	4.4	4.2	4.3	4.3	4.3	4.4
105	T.C.	46.9	47.7	44.9	51.1	52.9	49.0	49.3	46.2	52.3	54.3	51.0	50.9	47.5	53.6	55.8
	S.C.	42.8	42.0	34.8	34.7	25.5	44.7	44.5	37.3	37.2	27.3	46.6	46.9	39.8	39.8	29.2
	KW	4.8	4.9	4.9	4.9	5.0	4.8	4.9	4.9	4.9	5.0	4.8	4.9	4.9	5.0	5.0
115	T.C.	44.6	45.2	42.3	48.3	50.0	46.6	46.7	43.6	49.5	51.3	48.6	48.1	44.8	50.6	52.5
	S.C.	40.7	40.2	33.5	33.3	24.5	42.4	42.2	35.9	35.8	26.2	44.2	44.2	38.3	38.3	28.0
	KW	5.3	5.5	5.5	5.5	5.6	5.4	5.5	5.5	5.5	5.6	5.4	5.5	5.5	5.6	5.6
125	T.C.	42.3	42.8	39.7	45.6	47.2	44.2	44.0	40.9	46.6	48.2	46.2	45.3	42.2	47.6	49.3
	S.C.	38.5	38.5	32.3	32.0	23.4	40.1	40.0	34.5	34.4	25.1	41.8	41.5	36.8	36.9	26.8
	KW	5.9	6.0	6.1	6.1	6.2	6.0	6.1	6.1	6.1	6.2	6.0	6.1	6.1	6.2	6.2

NOTE: ALL CAPACITIES INCLUDE INDOOR FAN HEAT AT 1250 BTUH/1000 CFM.

Multipliers for determining the performance with other indoor sections.

NOTE: For dry bulb temperatures different than those listed (between 73-87 F), sensible capacity increases by 1060 BTUH per 1000 CFM per degree above the listed temperature and decreases by 1060 BTUH per 1000 CFM per degree below the listed temperature.

Air Handler	Coil	T.C.	S.C.	KW
MV20D	FC/MC62D	1.00	1.01	1.00
MA20D	FC/MC62D	1.00	1.00	1.00

Variable Speed Furnace	Coil	T.C.	S.C.	KW
(F,L)C8V*C20	FC/MC62D	1.00	1.00	1.00
FC9(C,V)*C20	FC/MC62D	1.00	1.01	1.00
FC9(C,V)*D20	FC/MC62D	0.98	1.01	0.98
C*(8,L)C*C20	FC/MC62D	1.00	0.97	0.95
C*9C*C20	FC/MC62D	0.99	0.97	0.98
C*9C*D20	FC/MC62D	0.99	0.96	0.97
G*9V*C20	FC/MC62D	0.99	0.97	0.98
G*9V*D20	FC/MC62D	0.99	0.96	0.97

HEATING PERFORMANCE DATA										
CONDENSING UNIT MODEL NO			CHJD18S21S1							
EVAPORATOR COIL MODEL NO			AHP18							
AIR TEMP. ENTERING OUTDOOR UNIT	AIR TEMP. ENTERING INDOOR COIL	ID CFM								
		450			600			750		
		MBTUH	KW	C.O.P.	MBTUH	KW	C.O.P.	MBTUH	KW	C.O.P.
60	60	19.7	4.21	1.37	21.0	4.24	1.45	22.3	4.29	1.52
	70	18.9	3.79	1.47	20.0	3.99	1.47	21.1	4.19	1.47
	80	18.1	3.37	1.57	19.0	3.73	1.49	19.8	4.08	1.42
47	60	17.4	3.83	1.33	18.3	4.15	1.29	19.1	4.51	1.24
	70	16.2	3.50	1.36	17.0	3.61	1.40	17.8	3.74	1.44
	80	14.9	3.16	1.38	15.7	3.06	1.50	16.5	2.96	1.63
40	60	14.9	3.49	1.25	15.9	3.78	1.23	16.8	4.06	1.21
	70	13.5	3.11	1.28	14.5	3.37	1.26	15.3	3.62	1.24
	80	12.1	2.72	1.30	13.0	2.95	1.29	13.8	3.18	1.27
30	60	13.0	3.28	1.16	13.5	3.46	1.14	14.0	3.69	1.11
	70	11.6	2.88	1.18	12.1	3.06	1.16	12.7	3.27	1.14
	80	10.1	2.48	1.19	10.7	2.65	1.18	11.4	2.85	1.17
17	60	9.7	2.78	1.02	10.1	2.92	1.01	10.4	3.04	1.00
	70	8.4	2.43	1.01	9.0	2.59	1.01	9.5	2.74	1.01
	80	7.1	2.08	1.00	7.8	2.26	1.01	8.5	2.44	1.02
10	60	8.2	2.58	0.93	8.3	2.61	0.93	8.5	2.70	0.92
	70	7.2	2.25	0.93	7.3	2.30	0.93	7.5	2.36	0.93
	80	6.1	1.92	0.93	6.3	1.98	0.93	6.5	2.02	0.94

NOTE: ALL CAPACITIES ARE NET (KBTUH) WITH INDOOR FAN HEAT ALREADY DEDUCTED AT 1250 BTUH/1000 CFM.

Multipliers for determining the performance with other indoor sections.

Air Handler	Coil	MBH	KW	COP
-	FC/MC/PC/UC18	1.00	1.00	1.00
-	FC/MC/PC/UC24	1.00	1.00	1.00
-	FC/MC/PC/UC30	1.00	1.00	1.00
-	HC18	1.00	1.00	1.00
AHP24	-	1.00	1.00	1.00
AV24	-	0.96	1.06	0.94
F4FP024	-	1.00	1.00	1.00
MV12B	FC/MC18B	0.97	1.05	0.95
MA08B	FC/MC18B	1.00	1.00	1.00
MV12B	FC/MC24B	0.97	1.06	0.94
MA08B	FC/MC24B	1.00	1.00	1.00
MV12B	FC/MC30B	0.97	1.06	0.94
MA08B	FC/MC30B	1.00	1.00	1.00

Variable Speed Furnace	Coil	MBH	KW	COP
(F,L)C8V*A12	FC/MC/PC/UC18A	0.97	1.06	0.94
FC9V*A12	FC/MC/PC/UC18A	0.97	1.04	0.96
FC9(C,V)*B12	FC/MC/PC/UC18B	0.97	1.06	0.94
(F,L)C8V*A12	FC/MC/PC/UC24A	0.97	1.06	0.94
FC9V*A12	FC/MC/PC/UC24A	0.97	1.04	0.96
FC9(C,V)*B12	FC/MC/PC/UC24B	0.97	1.06	0.94
(F,L)C8V*A12	FC/MC/PC/UC30A	0.97	1.06	0.94
FC9V*A12	FC/MC/PC/UC30A	0.97	1.04	0.96
FC9(C,V)*B12	FC/MC/PC/UC30B	0.97	1.06	0.94
(F,L)C8V*A12	HC18	0.97	1.06	0.94
FC9V*A12	HC18	0.97	1.04	0.96
C*(8,L)C*A12	FC/MC/PC18A	0.98	1.06	0.92
C*(8,L)C*B12	FC/MC/PC18B	0.97	1.06	0.92
C*9C*B12	FC/MC/PC18B	0.98	1.07	0.92
C*(8,L)C*A12	FC/MC/PC24A	1.01	1.10	0.91
C*(8,L)C*B12	FC/MC/PC24B	0.99	1.10	0.90
C*9C*B12	FC/MC/PC24B	1.00	1.11	0.90

Variable Speed Furnace	Coil	MBH	KW	COP
C*(8,L)C*A12	FC/MC/PC30A	1.01	1.10	0.91
C*(8,L)C*B12	FC/MC/PC30B	0.99	1.10	0.90
C*9C*B12	FC/MC/PC30B	1.00	1.11	0.90
C*(8,L)C*A12	HC18	0.98	1.06	0.92
C*(8,L)C*A12	HD24	0.99	1.08	0.92
C*(8,L)C*B12	HD24	0.97	1.06	0.91
C*9C*B12	HD24	0.99	1.09	0.91
C*(8,L)C*A12	UC18A	0.99	1.08	0.92
C*(8,L)C*B12	UC18B	0.98	1.07	0.92
C*9C*B12	UC18B	0.99	1.08	0.91
C*(8,L)C*A12	UC24A	1.01	1.11	0.91
C*(8,L)C*B12	UC24B	0.99	1.11	0.90
C*9C*B12	UC24B	1.01	1.12	0.90
C*(8,L)C*A12	UC30A	1.01	1.11	0.91
C*(8,L)C*B12	UC30B	0.99	1.11	0.90
C*9C*B12	UC30B	1.01	1.12	0.90
G*9V*A12	FC/MC/PC18A	0.99	1.05	0.94
G*9V*B12	FC/MC/PC18B	0.98	1.07	0.92
G*9V*A12	FC/MC/PC24A	1.01	1.09	0.92
G*9V*B12	FC/MC/PC24B	1.00	1.11	0.90
G*9V*A12	FC/MC/PC30A	1.01	1.09	0.92
G*9V*B12	FC/MC/PC30B	1.00	1.11	0.90
G*9V*A12	HC18	0.99	1.05	0.94
G*9V*A12	HD24	0.99	1.06	0.94
G*9V*B12	HD24	0.99	1.09	0.91
G*9V*A12	UC18A	1.00	1.07	0.93
G*9V*B12	UC18B	0.99	1.08	0.91
G*9V*A12	UC24A	1.01	1.10	0.92
G*9V*B12	UC24B	1.01	1.12	0.90
G*9V*A12	UC30A	1.01	1.10	0.92
G*9V*B12	UC30B	1.01	1.12	0.90

HEATING PERFORMANCE DATA										
CONDENSING UNIT MODEL NO		CHJD24S21S1								
EVAPORATOR COIL MODEL NO		AHP24								
AIR TEMP. ENTERING OUTDOOR UNIT	AIR TEMP. ENTERING INDOOR COIL	ID CFM								
		600			800			1000		
		MBTUH	KW	C.O.P.	MBTUH	KW	C.O.P.	MBTUH	KW	C.O.P.
60	60	25.6	4.23	1.77	26.9	4.47	1.76	28.3	4.70	1.76
	70	24.4	4.09	1.75	25.8	4.41	1.71	27.3	4.75	1.68
	80	23.2	3.95	1.72	24.7	4.35	1.66	26.2	4.79	1.60
47	60	21.8	4.46	1.43	23.1	4.90	1.38	24.3	5.35	1.33
	70	20.6	4.03	1.51	21.9	4.20	1.56	23.2	4.40	1.61
	80	19.4	3.59	1.58	20.7	3.50	1.73	22.1	3.44	1.88
40	60	19.5	4.10	1.39	20.8	4.54	1.34	22.0	4.99	1.29
	70	18.6	3.76	1.46	19.8	4.12	1.42	21.0	4.49	1.38
	80	17.7	3.41	1.52	18.8	3.69	1.49	19.9	3.99	1.46
30	60	17.3	3.95	1.28	18.0	4.15	1.27	18.7	4.34	1.26
	70	16.0	3.54	1.33	16.8	3.73	1.33	17.6	3.93	1.32
	80	14.7	3.12	1.38	15.6	3.31	1.38	16.5	3.52	1.37
17	60	12.8	2.71	1.38	13.5	3.16	1.25	14.1	3.68	1.12
	70	11.7	2.67	1.28	12.4	2.98	1.21	13.0	3.33	1.14
	80	10.6	2.63	1.18	11.2	2.80	1.17	11.8	2.97	1.16
10	60	9.5	2.67	1.04	10.7	2.92	1.07	11.9	3.16	1.10
	70	9.2	2.50	1.08	10.1	2.71	1.09	10.9	2.91	1.10
	80	8.9	2.32	1.12	9.4	2.50	1.10	9.9	2.66	1.09

NOTE: ALL CAPACITIES ARE NET (KBTUH) WITH INDOOR FAN HEAT ALREADY DEDUCTED AT 1250 BTUH/1000 CFM.

Multipliers for determining the performance with other indoor sections.

Air Handler	Coil	MBH	KW	COP
–	FC/MC/PC/UC24	1.00	1.00	1.00
–	FC/MC/PC/UC30	1.00	1.00	1.00
–	FC/MC/PC/UC32	1.00	1.00	1.00
–	FC/MC/PC/UC35	1.00	1.00	1.00
–	HC30	1.00	1.00	1.00
–	HC36	1.00	1.00	1.00
–	HD24	1.00	1.00	1.00
–	MH24S	1.00	1.00	1.00
–	MH30S	1.00	1.00	1.00
AHP30	–	1.00	1.00	1.00

Air Handler	Coil	MBH	KW	COP
AV24	–	0.97	1.08	0.92
FPP030	–	1.00	1.00	1.00
MV12B	FC/MC24B	0.98	1.07	0.93
MA08B	FC/MC24B	1.00	1.00	1.00
MV12B	FC/MC30B	0.98	1.07	0.93
MA08B	FC/MC30B	1.00	1.00	1.00
MV12B	FC/MC35B	0.97	1.07	0.93
MA08B	FC/MC35B	1.00	1.00	1.00

Continued on Page 42.

Variable Speed Furnace	Coil	MBH	KW	COP
(F,L)C8V*A12	FC/MC/PC/UC24A	0.98	1.05	0.95
FC9V*A12	FC/MC/PC/UC24A	0.98	1.04	0.96
FC9(C,V)*B12	FC/MC/PC/UC24B	0.98	1.05	0.95
(F,L)C8V*A12	FC/MC/PC/UC30A	0.98	1.05	0.95
FC9V*A12	FC/MC/PC/UC30A	0.98	1.05	0.95
FC9(C,V)*B12	FC/MC/PC/UC30B	0.98	1.05	0.95
(F,L)C8V*A12	FC/MC/PC/UC32A	0.98	1.05	0.95
FC9V*A12	FC/MC/PC/UC32A	0.98	1.05	0.95
FC9(C,V)*B12	FC/MC/PC/UC35B	0.98	1.05	0.95
(F,L)C8V*A12	HC30	0.98	1.05	0.95
FC9V*A12	HC30	0.98	1.05	0.95
FC9(C,V)*B12	HC36	0.98	1.05	0.95
C*(8,L)C*A12	FC/MC/PC24A	0.98	1.06	0.93
C*(8,L)C*B12	FC/MC/PC24B	0.98	1.07	0.92
C*9C*B12	FC/MC/PC24B	0.98	1.06	0.93
C*(8,L)C*A12	FC/MC/PC30A	0.98	1.06	0.93
C*(8,L)C*B12	FC/MC/PC30B	0.98	1.07	0.92
C*9C*B12	FC/MC/PC30B	0.98	1.06	0.93
C*(8,L)C*A12	FC/MC/PC32A	0.98	1.04	0.94
C*(8,L)C*B12	FC/MC/PC35B	0.98	1.06	0.92
C*9C*B12	FC/MC/PC35B	0.98	1.06	0.93
C*(8,L)C*A12	FC/MC/PC36A	0.98	1.07	0.92
C*(8,L)C*B12	FC/MC/PC36B	0.98	1.08	0.91
C*9C*B12	FC/MC/PC36B	0.98	1.07	0.92
C*(8,L)C*A12	FC/MC/PC37A	0.99	1.07	0.93
C*(8,L)C*B12	FC/MC/PC43B	0.98	1.08	0.91
C*9C*B12	FC/MC/PC43B	0.99	1.08	0.92
C*(8,L)C*A12	HC30	0.97	1.03	0.95
C*(8,L)C*B12	HC36	0.97	1.05	0.92
C*9C*B12	HC36	0.98	1.05	0.93
C*(8,L)C*A12	HD36	0.92	0.94	0.98
C*(8,L)C*B12	HD36	0.91	0.93	0.98
C*(8,L)C*C16	HD36	0.92	0.96	0.96
C*(8,L)C*C20	HD36	0.90	0.94	0.96

Variable Speed Furnace	Coil	MBH	KW	COP
C*9C*B12	HD36	0.92	0.94	0.98
C*9C*C16	HD36	0.91	0.94	0.97
C*9C*C20	HD36	0.90	0.93	0.97
C*(8,L)C*A12	UC24A	0.98	1.06	0.92
C*(8,L)C*B12	UC24B	0.98	1.07	0.91
C*9C*B12	UC24B	0.98	1.06	0.93
C*(8,L)C*A12	UC30A	0.98	1.06	0.92
C*(8,L)C*B12	UC30B	0.98	1.07	0.91
C*9C*B12	UC30B	0.98	1.06	0.93
C*(8,L)C*A12	UC36A	0.97	1.04	0.93
C*(8,L)C*B12	UC36B	0.97	1.06	0.92
C*9C*B12	UC36B	0.97	1.04	0.93
G*9V*A12	FC/MC/PC24A	0.98	1.04	0.94
G*9V*B12	FC/MC/PC24B	0.98	1.06	0.93
G*9V*A12	FC/MC/PC30A	0.98	1.04	0.94
G*9V*B12	FC/MC/PC30B	0.98	1.06	0.93
G*9V*A12	FC/MC/PC32A	0.99	1.03	0.96
G*9V*B12	FC/MC/PC35B	0.98	1.06	0.93
G*9V*A12	FC/MC/PC36A	0.99	1.05	0.94
G*9V*B12	FC/MC/PC36B	0.98	1.07	0.92
G*9V*A12	FC/MC/PC37A	0.99	1.06	0.94
G*9V*B12	FC/MC/PC43B	0.99	1.08	0.92
G*9V*A12	HC30	0.98	1.03	0.95
G*9V*B12	HC36	0.98	1.05	0.93
G*9V*A12	HD36	0.92	0.92	1.00
G*9V*B12	HD36	0.92	0.94	0.98
G*9V*C16	HD36	0.91	0.94	0.97
G*9V*C20	HD36	0.90	0.93	0.97
G*9V*A12	UC24A	0.99	1.05	0.94
G*9V*B12	UC24B	0.98	1.06	0.93
G*9V*A12	UC30A	0.99	1.05	0.94
G*9V*B12	UC30B	0.98	1.06	0.93
G*9V*A12	UC36A	0.98	1.03	0.95
G*9V*B12	UC36B	0.97	1.04	0.93

HEATING PERFORMANCE DATA										
CONDENSING UNIT MODEL NO		CHJD30S21S1								
EVAPORATOR COIL MODEL NO		AHP30								
AIR TEMP. ENTERING OUTDOOR UNIT	AIR TEMP. ENTERING INDOOR COIL	ID CFM								
		800			1000			1200		
		MBTUH	KW	C.O.P.	MBTUH	KW	C.O.P.	MBTUH	KW	C.O.P.
60	60	35.2	4.14	2.49	36.8	4.38	2.46	38.3	4.59	2.44
	70	33.8	3.80	2.62	35.4	4.00	2.60	36.9	4.20	2.58
	80	32.5	3.46	2.75	34	3.63	2.74	35.5	3.82	2.72
47	60	29.3	3.69	2.32	29.9	3.75	2.33	30.6	3.81	2.35
	70	28	3.39	2.42	28.7	3.43	2.46	29.4	3.46	2.50
	80	26.7	3.10	2.52	27.5	3.11	2.59	28.3	3.12	2.65
40	60	25.8	3.38	2.23	26.8	3.50	2.24	27.7	3.59	2.26
	70	24.5	3.12	2.30	25.5	3.22	2.32	26.4	3.30	2.35
	80	23.3	2.86	2.38	24.3	2.95	2.41	25.2	3.02	2.44
30	60	21.1	2.97	2.08	21.7	3.01	2.11	22.4	3.05	2.15
	70	19.8	2.72	2.13	20.4	2.76	2.17	21.1	2.80	2.21
	80	18.5	2.47	2.19	19.2	2.51	2.24	19.9	2.55	2.28
17	60	14.8	2.29	1.89	15.2	2.29	1.94	15.7	2.31	1.99
	70	13.5	2.09	1.89	13.9	2.08	1.95	14.4	2.10	2.01
	80	12.2	1.89	1.89	12.7	1.88	1.97	13.2	1.89	2.04
10	60	11.3	1.84	1.79	11.9	1.88	1.85	12.5	1.90	1.92
	70	10.2	1.68	1.78	10.7	1.70	1.84	11.2	1.72	1.90
	80	9.2	1.52	1.77	9.6	1.53	1.83	10	1.54	1.89

NOTE: ALL CAPACITIES ARE NET (KBTUH) WITH INDOOR FAN HEAT ALREADY DEDUCTED AT 1250 BTUH/1000 CFM.

Multipliers for determining the performance with other indoor sections.

Air Handler	Coil	MBH	KW	COP
–	FC/MC/PC/UC32	1.00	1.00	1.00
–	FC/MC/PC/UC35	1.00	1.00	1.00
–	FC/MC/PC/UC37	1.00	1.00	1.00
–	FC/MC/PC/UC43	1.00	1.00	1.00
–	HC36	1.00	1.00	1.00
–	HC42	1.00	1.00	1.00
–	HD36	1.00	1.00	1.00
–	MH240S	1.00	1.00	1.00
–	MH30S	1.00	1.00	1.00
AHP36	–	1.00	1.00	1.00

Air Handler	Coil	MBH	KW	COP
AV36	–	0.97	1.07	0.93
FPP040	–	1.00	1.00	1.00
MV12B	FC/MC35B	0.97	1.06	0.94
MV16C	FC/MC35C	0.97	1.06	0.94
MA12B	FC/MC35B	1.00	1.00	1.00
MV12B	FC/MC43B	0.97	1.05	0.95
MV16C	FC/MC43C	0.97	1.06	0.94
MA12B	FC/MC43B	1.00	1.00	1.00

Continued on Page 44.

Variable Speed Furnace	Coil	MBH	KW	COP
(F,L)C8V*A12	FC/MC/PC/UC32A	0.98	1.03	0.97
FC9V*A12	FC/MC/PC/UC32A	0.98	1.03	0.97
(F,L)C8V*B16	FC/MC/PC/UC35B	0.97	1.06	0.94
(F,L)C8V*C16	FC/MC/PC/UC35C	0.97	1.06	0.94
(F,L)C8V*C20	FC/MC/PC/UC35C	0.98	1.03	0.97
FC9(C,V)*B12	FC/MC/PC/UC35B	0.97	1.04	0.96
FC9(C,V)*C16	FC/MC/PC/UC35C	0.97	1.05	0.95
(F,L)C8V*A12	FC/MC/PC/UC37A	0.98	1.03	0.97
FC9V*A12	FC/MC/PC/UC37A	0.98	1.03	0.97
(F,L)C8V*B16	FC/MC/PC/UC43B	0.97	1.06	0.94
(F,L)C8V*C16	FC/MC/PC/UC43C	0.97	1.06	0.94
(F,L)C8V*C20	FC/MC/PC/UC43C	0.98	1.03	0.97
FC9(C,V)*B12	FC/MC/PC/UC43B	0.97	1.05	0.95
FC9(C,V)*C16	FC/MC/PC/UC43C	0.97	1.05	0.95
(F,L)C8V*B16	HC36	0.97	1.06	0.94
FC9(C,V)*B12	HC36	0.97	1.04	0.96
(F,L)C8V*C16	HC42	0.97	1.06	0.94
(F,L)C8V*C20	HC42	0.98	1.03	0.97
FC9(C,V)*C16	HC42	0.97	1.05	0.95
C*(8,L)C*A12	FC/MC/PC32A	0.99	0.99	1.00
C*(8,L)C*B12	FC/MC/PC35B	0.98	1.03	0.95
C*9C*B12	FC/MC/PC35B	0.99	1.01	0.98
C*(8,L)C*C16	FC/MC/PC35C	0.97	1.04	0.94
C*(8,L)C*C20	FC/MC/PC35C	0.98	1.05	0.94
C*9C*C16	FC/MC/PC35C	0.98	1.04	0.94
C*9C*C20	FC/MC/PC35C	0.97	1.04	0.94
C*(8,L)C*A12	FC/MC/PC36A	0.98	1.02	0.96
C*(8,L)C*B12	FC/MC/PC36B	0.97	1.03	0.94
C*9C*B12	FC/MC/PC36B	0.98	1.03	0.95
C*(8,L)C*C16	FC/MC/PC36C	0.97	1.04	0.93
C*(8,L)C*C20	FC/MC/PC36C	0.97	1.05	0.93
C*9C*C16	FC/MC/PC36C	0.97	1.04	0.93
C*9C*C20	FC/MC/PC36C	0.98	1.04	0.94
C*(8,L)C*A12	FC/MC/PC37A	0.99	1.02	0.97
C*(8,L)C*B12	FC/MC/PC43B	0.98	1.05	0.94
C*9C*B12	FC/MC/PC43B	0.99	1.03	0.96
C*(8,L)C*C16	FC/MC/PC43C	0.98	1.07	0.92
C*(8,L)C*C20	FC/MC/PC43C	0.98	1.07	0.92
C*9C*C16	FC/MC/PC43C	0.98	1.05	0.94
C*9C*C20	FC/MC/PC43C	0.98	1.06	0.93
C*(8,L)C*B12	HC36	0.98	1.02	0.96
C*9C*B12	HC36	0.99	1.01	0.98

Variable Speed Furnace	Coil	MBH	KW	COP
C*(8,L)C*C16	HC42	0.98	1.06	0.92
C*(8,L)C*C20	HC42	0.98	1.07	0.92
C*9C*C16	HC42	0.98	1.05	0.94
C*9C*C20	HC42	0.98	1.06	0.93
C*(8,L)C*A12	HD36	0.94	0.92	1.02
C*(8,L)C*B12	HD36	0.93	0.93	1.00
C*(8,L)C*C16	HD36	0.93	0.94	0.99
C*(8,L)C*C20	HD36	0.94	0.95	0.98
C*9C*B12	HD36	0.93	0.93	1.00
C*9C*C16	HD36	0.93	0.94	0.99
C*9C*C20	HD36	0.93	0.93	1.00
C*(8,L)C*A12	UC36A	0.97	1.00	0.97
C*(8,L)C*B12	UC36B	0.97	1.01	0.96
C*9C*B12	UC36B	0.97	1.01	0.96
C*(8,L)C*C16	UC36C	0.97	1.02	0.95
C*(8,L)C*C20	UC36C	0.96	1.02	0.94
C*9C*C16	UC36C	0.97	1.02	0.95
C*9C*C20	UC36C	0.97	1.02	0.95
G*9V*A12	FC/MC/PC32A	0.98	1.01	0.97
G*9V*B12	FC/MC/PC35B	0.99	1.01	0.98
G*9V*C16	FC/MC/PC35C	0.98	1.04	0.94
G*9V*C20	FC/MC/PC35C	0.97	1.04	0.94
G*9V*B12	FC/MC/PC36B	0.98	1.03	0.95
G*9V*A12	FC/MC/PC36A	0.98	1.02	0.96
G*9V*C16	FC/MC/PC36C	0.97	1.04	0.93
G*9V*C20	FC/MC/PC36C	0.98	1.04	0.94
G*9V*A12	FC/MC/PC37A	0.99	1.03	0.97
G*9V*B12	FC/MC/PC43B	0.99	1.03	0.96
G*9V*C16	FC/MC/PC43C	0.98	1.05	0.94
G*9V*C20	FC/MC/PC43C	0.98	1.06	0.93
G*9V*B12	HC36	0.99	1.01	0.98
G*9V*C16	HC42	0.98	1.05	0.94
G*9V*C20	HC42	0.98	1.06	0.93
G*9V*A12	HD36	0.94	0.92	1.02
G*9V*B12	HD36	0.93	0.93	1.00
G*9V*C16	HD36	0.93	0.94	0.99
G*9V*C20	HD36	0.93	0.93	1.00
G*9V*A12	UC36A	0.97	1.00	0.98
G*9V*B12	UC36B	0.97	1.01	0.96
G*9V*C16	UC36C	0.97	1.02	0.95
G*9V*C20	UC36C	0.97	1.02	0.95

HEATING PERFORMANCE DATA										
CONDENSING UNIT MODEL NO		CHJD36S21S1								
EVAPORATOR COIL MODEL NO		AHP36								
AIR TEMP. ENTERING OUTDOOR UNIT	AIR TEMP. ENTERING INDOOR COIL	ID CFM								
		1000			1200			1400		
		MBTUH	KW	C.O.P.	MBTUH	KW	C.O.P.	MBTUH	KW	C.O.P.
60	60	41.6	2.4	5.0	42.2	2.3	5.3	42.7	2.2	5.6
	70	40.1	2.6	4.5	40.8	2.5	4.8	41.5	2.4	5.1
	80	38.6	2.8	4.1	39.5	2.7	4.3	40.4	2.6	4.6
47	60	35.3	2.3	4.6	35.5	2.2	4.8	35.7	2.1	4.9
	70	33.8	2.4	4.2	34.3	2.3	4.3	34.8	2.3	4.5
	80	32.4	2.5	3.7	33.1	2.5	3.9	33.8	2.4	4.1
40	60	31.4	2.2	4.2	31.4	2.1	4.4	31.5	2.0	4.5
	70	30.2	2.3	3.9	30.6	2.2	4.0	31.0	2.2	4.2
	80	29.1	2.4	3.5	29.8	2.4	3.7	30.4	2.3	3.8
30	60	27.4	2.0	3.9	27.3	2.0	4.0	27.3	2.0	4.1
	70	26.1	2.1	3.6	26.4	2.1	3.7	26.7	2.1	3.8
	80	24.9	2.2	3.3	25.5	2.2	3.4	26.1	2.2	3.5
17	60	21.4	1.9	3.4	21.5	1.8	3.4	21.7	1.8	3.5
	70	19.9	1.9	3.0	20.2	1.9	3.1	20.6	1.9	3.2
	80	18.4	2.0	2.7	18.9	2.0	2.8	19.4	2.0	2.9
10	60	17.9	1.8	3.0	17.8	1.7	3.0	17.7	1.7	3.0
	70	16.8	1.8	2.7	17.0	1.8	2.8	17.2	1.8	2.9
	80	15.7	1.8	2.5	16.1	1.8	2.6	16.6	1.8	2.7

NOTE: ALL CAPACITIES ARE NET (KBTUH) WITH INDOOR FAN HEAT ALREADY DEDUCTED AT 1250 BTUH/1000 CFM.

Multipliers for determining the performance with other indoor sections.

Air Handler	Coil	MBH	KW	COP
-	FC/MC/PC/UC37	1.00	1.00	1.00
-	FC/MC/PC/UC43	1.00	1.00	1.00
-	FC/MC/PC/UC48	1.00	1.00	1.00
-	FC/MC/PC/UC60	1.00	1.00	1.00
-	HC42	1.00	1.00	1.00
-	HC60	1.00	1.00	1.00
-	HD48	1.00	1.00	1.00
-	HD60	1.00	1.00	1.00
AHP42	-	1.00	1.00	1.00
AHP/SHP60	-	0.98	1.04	0.96
F5FP045	-	1.00	1.00	1.00
F4FV060	-	0.98	1.04	0.96
F5FP048	-	0.98	1.04	0.96
F5FP060	-	0.98	1.04	0.96

Air Handler	Coil	MBH	KW	COP
AV36	-	0.98	1.04	0.96
AV/SV48	-	0.98	1.04	0.96
MV16C	FC/MC43C	0.97	1.06	0.94
MV12B	FC/MC43B	0.98	1.03	0.97
MA12B	FC/MC43B	1.00	1.00	1.00
MV16C	FC/MC48C	0.97	1.06	0.94
MV16C	FC60C	0.97	1.06	0.94
MV12D	FC/MC48D	0.97	1.06	0.94
MA14D	FC/MC48D	1.00	1.00	1.00
MV12D	FC/MC48D	0.97	1.05	0.95
MA14D	FC/MC60D	1.00	1.00	1.00
MV12D	FC/MC60D	0.97	1.06	0.94

Continued on Page 46.

Variable Speed Furnace	Coil	MBH	KW	COP
(F,L)C8V*A12	FC/MC/PC/UC37A	0.98	1.02	0.98
FC9V*A12	FC/MC/PC/UC37A	1.00	1.00	1.00
(F,L)C8V*B16	FC/MC/PC/UC43B	0.98	1.04	0.96
(F,L)C8V*C16	FC/MC/PC/UC43C	0.98	1.05	0.95
(F,L)C8V*C20	FC/MC/PC/UC43C	0.98	1.03	0.97
FC9(C,V)*B12	FC/MC/PC/UC43B	0.98	1.02	0.98
FC9(C,V)*C16	FC/MC/PC/UC43C	0.98	1.04	0.96
FC9(C,V)*C20	FC/MC/PC/UC43C	0.98	1.04	0.96
(F,L)C8V*C16	FC/MC/PC/UC48C	0.97	1.05	0.95
(F,L)C8V*C20	FC/MC/PC/UC48C	0.98	1.03	0.97
FC9(C,V)*C16	FC/MC/PC/UC48C	0.98	1.05	0.95
FC9(C,V)*C20	FC/MC/PC/UC48C	0.98	1.05	0.95
FC9(C,V)*D20	FC/MC/PC/UC48D	0.98	1.05	0.95
(F,L)C8V*C16	HC42	0.97	1.05	0.95
(F,L)C8V*C20	HC42	0.98	1.03	0.97
FC9(C,V)*C16	HC42	0.98	1.04	0.96
FC9(C,V)*C20	HC42	0.98	1.05	0.95
C*(8,L)C*A12	FC/MC/PC37A	0.96	0.99	0.97
C*(8,L)C*B12	FC/MC/PC43B	1.00	1.02	0.97
C*9C*B12	FC/MC/PC43B	0.99	1.02	0.97
C*(8,L)C*C16	FC/MC/PC43C	0.99	1.05	0.94
C*(8,L)C*C20	FC/MC/PC43C	0.98	1.06	0.93
C*9C*C16	FC/MC/PC43C	0.99	1.03	0.96
C*9C*C20	FC/MC/PC43C	0.99	1.05	0.94
C*(8,L)C*C16	FC/MC/PC48C	0.99	1.06	0.93
C*(8,L)C*C20	FC/MC/PC48C	0.98	1.07	0.92
C*9C*C16	FC/MC/PC48C	0.99	1.05	0.94
C*9C*C20	FC/MC/PC48C	1.00	1.05	0.95

Variable Speed Furnace	Coil	MBH	KW	COP
C*(8,L)C*C16	HC42	0.98	1.05	0.94
C*(8,L)C*C20	HC42	0.98	1.06	0.93
C*9C*C16	HC42	0.99	1.03	0.96
C*9C*C20	HC42	0.99	1.05	0.94
C*(8,L)C*B12	HD48	0.96	0.97	0.99
C*(8,L)C*C16	HD48	0.95	0.99	0.96
C*(8,L)C*C20	HD48	0.95	0.99	0.95
C*9C*B12	HD48	0.96	0.96	1.00
C*9C*C16	HD48	0.95	0.98	0.98
C*9C*C20	HD48	0.97	0.98	0.99
C*(8,L)C*C16	UC48C	0.98	1.08	0.91
C*(8,L)C*C20	UC48C	0.98	1.09	0.90
C*9C*C16	UC48C	0.99	1.07	0.93
C*9C*C20	UC48C	1.00	1.06	0.94
G*9V*A12	FC/MC/PC37A	0.97	0.99	0.97
G*9V*B12	FC/MC/PC43B	0.99	1.02	0.97
G*9V*C16	FC/MC/PC43C	0.99	1.03	0.96
G*9V*C20	FC/MC/PC43C	0.99	1.05	0.94
G*9V*C16	FC/MC/PC48C	0.99	1.05	0.94
G*9V*C20	FC/MC/PC48C	1.00	1.05	0.95
G*9V*C16	HC42	0.99	1.03	0.96
G*9V*C20	HC42	0.99	1.05	0.94
G*9V*B12	HD48	0.96	0.96	1.00
G*9V*C16	HD48	0.95	0.98	0.98
G*9V*C20	HD48	0.97	0.98	0.99
G*9V*C16	UC48C	0.99	1.07	0.93
G*9V*C20	UC48C	1.00	1.06	0.94

HEATING PERFORMANCE DATA										
CONDENSING UNIT MODEL NO		CHJD42S21S1								
EVAPORATOR COIL MODEL NO		FC/MC/PC/UC48								
AIR TEMP. ENTERING OUTDOOR UNIT	AIR TEMP. ENTERING INDOOR COIL	ID CFM								
		1200			1400			1600		
		MBTUH	KW	C.O.P.	MBTUH	KW	C.O.P.	MBTUH	KW	C.O.P.
60	60	51.7	3.1	4.3	52.6	3.0	4.4	53.4	2.9	4.5
	70	49.6	3.2	3.9	50.4	3.2	4.0	51.3	3.1	4.1
	80	47.4	3.4	3.6	48.3	3.3	3.7	49.2	3.3	3.8
47	60	40.4	2.8	3.6	42.2	2.7	3.8	44.0	2.7	4.0
	70	39.7	3.0	3.4	42.0	2.9	3.6	42.5	2.8	3.6
	80	39.1	3.1	3.2	40.1	3.1	3.3	41.1	3.0	3.4
40	60	38.4	2.7	3.6	39.1	2.6	3.7	39.8	2.6	3.7
	70	35.7	2.8	3.3	36.9	2.7	3.3	38.1	2.7	3.4
	80	33.1	2.9	2.9	34.8	2.9	3.0	36.5	2.9	3.1
30	60	33.5	2.5	3.3	33.4	2.5	3.3	33.3	2.4	3.3
	70	31.0	2.6	3.0	31.7	2.6	3.0	32.3	2.5	3.0
	80	28.6	2.7	2.7	30.0	2.7	2.8	31.3	2.7	2.8
17	60	27.1	2.3	2.9	27.4	2.3	2.9	27.7	2.3	2.9
	70	25.2	2.4	2.6	25.0	2.4	2.6	26.4	2.4	2.6
	80	23.3	2.5	2.4	24.1	2.5	2.4	25.0	2.4	2.4
10	60	24.1	2.2	2.7	24.3	2.2	2.7	24.6	2.1	2.6
	70	22.6	2.3	2.5	22.9	2.2	2.4	23.2	2.2	2.4
	80	21.2	2.3	2.2	21.5	2.3	2.2	21.9	2.3	2.2

NOTE: ALL CAPACITIES ARE NET (KBTUH) WITH INDOOR FAN HEAT ALREADY DEDUCTED AT 1250 BTUH/1000 CFM.

Multipliers for determining the performance with other indoor sections.

Air Handler	Coil	MBH	KW	COP
–	FC/MC/PC/UC60	1.00	1.00	1.00
–	HC60	1.00	1.00	1.00
–	HD60	1.00	1.00	1.00
AHP/SHP48	–	1.00	1.01	0.99
AHP/SHP60	–	0.97	1.05	0.95
AV/SV48	–	0.96	1.04	0.96
AV/SV60	–	0.97	1.05	0.95
F4FV060	–	0.97	1.05	0.95
F5FP045	–	1.00	1.01	0.99
F5FP048	–	0.97	1.05	0.95

Air Handler	Coil	MBH	KW	COP
F5FP060	–	0.97	1.05	0.95
MV16C	FC/MC48C	0.96	1.04	0.96
MV16C	FC60C	0.96	1.04	0.96
MV20D	FC/MC48D	0.97	1.05	0.95
MA14D	FC/MC48D	1.00	1.00	1.00
MA16C	FC/MC48C	1.00	1.00	1.00
MV20D	FC/MC60D	0.97	1.05	0.95
MA14D	FC/MC60D	1.00	1.00	1.00
MA16C	FC60C	1.00	1.00	1.00

Continued on Page 48.

Variable Speed Furnace	Coil	MBH	KW	COP
(F,L)C8V*C16	FC/MC/PC/UC48C	0.98	1.02	0.98
(F,L)C8V*C20	FC/MC/PC/UC48C	0.98	1.03	0.97
FC9(C,V)*C16	FC/MC/PC/UC48C	0.98	1.02	0.98
FC9(C,V)*C20	FC/MC/PC/UC48C	0.98	1.02	0.98
FC9(C,V)*D20	FC/MC/PC/UC48D	0.98	1.02	0.98
(F,L)C8V*C16	FC/PC/UC60C	0.98	1.02	0.98
(F,L)C8V*C20	FC/PC/UC60C	0.98	1.03	0.97
FC9(C,V)*C16	FC/PC/UC60C	0.98	1.02	0.98
FC9(C,V)*C20	FC/PC/UC60C	0.98	1.02	0.98
FC9(C,V)*D20	FC/MC/PC/UC60D	0.98	1.02	0.98
C*(8,L)C*C16	FC/MC/PC48C	0.99	1.04	0.95
C*(8,L)C*C20	FC/MC/PC48C	0.99	1.05	0.95
C*9C*C16	FC/MC/PC48C	0.99	1.03	0.96
C*9C*C20	FC/MC/PC48C	1.00	1.03	0.97
C*9C*D20	FC/MC/PC48D	0.99	1.04	0.96
C*9C*D20	FC/MC/PC60D	1.00	1.06	0.94
C*(8,L)C*C16	FC/PC60C	1.00	1.07	0.94
C*(8,L)C*C20	FC/PC60C	1.00	1.08	0.92
C*9C*C16	FC/PC60C	1.01	1.04	0.97
C*9C*C20	FC/PC60C	1.00	1.06	0.95
C*(8,L)C*B12	HD48	0.97	0.95	1.02
C*(8,L)C*C16	HD48	0.97	0.98	0.99
C*(8,L)C*C20	HD48	0.97	0.99	0.98
C*9C*B12	HD48	0.94	0.93	1.01
C*9C*C16	HD48	0.98	0.98	1.00
C*9C*C20	HD48	0.98	0.97	1.01
C*9C*D20	HD48	0.97	0.98	1.00

Variable Speed Furnace	Coil	MBH	KW	COP
C*(8,L)C*C16	UC48C	1.00	1.06	0.95
C*(8,L)C*C20	UC48C	1.00	1.06	0.94
C*9C*C16	UC48C	1.00	1.05	0.96
C*9C*C20	UC48C	1.00	1.04	0.96
C*9C*D20	UC48D	1.00	1.05	0.95
C*(8,L)C*C16	UC60C	1.00	1.06	0.94
C*(8,L)C*C20	UC60C	0.99	1.07	0.93
C*9C*C16	UC60C	1.00	1.03	0.97
C*9C*C20	UC60C	1.00	1.04	0.96
C*9C*D20	UC60D	1.00	1.05	0.95
G*9V*C16	FC/MC/PC48C	0.99	1.03	0.96
G*9V*C20	FC/MC/PC48C	1.00	1.03	0.97
G*9V*D20	FC/MC/PC48D	0.99	1.04	0.96
G*9V*D20	FC/MC/PC60D	1.00	1.06	0.94
G*9V*C16	FC/PC60C	1.01	1.04	0.97
G*9V*C20	FC/PC60C	1.00	1.06	0.95
G*9V*B12	HD48	0.94	0.93	1.01
G*9V*C16	HD48	0.98	0.98	1.00
G*9V*C20	HD48	0.98	0.97	1.01
G*9V*D20	HD48	0.97	0.98	1.00
G*9V*C16	UC48C	1.00	1.05	0.96
G*9V*C20	UC48C	1.00	1.04	0.96
G*9V*D20	UC48D	1.00	1.05	0.95
G*9V*C16	UC60C	1.00	1.03	0.97
G*9V*C20	UC60C	1.00	1.04	0.96
G*9V*D20	UC60D	1.00	1.05	0.95

HEATING PERFORMANCE DATA										
CONDENSING UNIT MODEL NO		CHJD48S21S1								
EVAPORATOR COIL MODEL NO		AHP/SHP48								
AIR TEMP. ENTERING OUTDOOR UNIT	AIR TEMP. ENTERING INDOOR COIL	ID CFM								
		1400			1600			1800		
		MBTUH	KW	C.O.P.	MBTUH	KW	C.O.P.	MBTUH	KW	C.O.P.
60	60	64.7	3.3	4.9	64.7	3.4	4.8	64.8	3.4	4.7
	70	62.2	3.9	4.1	62.4	3.8	4.2	62.6	3.7	4.2
	80	59.7	4.4	3.5	60.0	4.3	3.6	60.3	4.1	3.7
47	60	54.3	3.4	4.1	54.5	3.3	4.2	54.7	3.1	4.2
	70	52.1	3.8	3.6	52.3	3.6	3.6	52.5	3.5	3.7
	80	49.8	4.1	3.2	50.1	4.0	3.2	50.3	3.8	3.3
40	60	49.1	3.2	3.8	49.2	3.1	3.9	49.4	3.0	3.9
	70	47.1	3.6	3.3	47.2	3.5	3.4	47.2	3.4	3.4
	80	45.0	4.0	2.9	45.1	3.9	3.0	45.1	3.7	3.0
30	60	42.5	3.1	3.5	42.9	3.0	3.5	43.2	3.0	3.5
	70	39.7	3.4	3.0	40.2	3.4	3.0	40.6	3.4	2.9
	80	36.9	3.7	2.6	37.5	3.8	2.5	38.1	3.9	2.5
17	60	34.5	2.8	3.0	34.9	2.9	3.0	35.3	2.9	2.9
	70	31.8	3.3	2.5	32.6	3.2	2.5	33.5	3.2	2.6
	80	29.1	3.7	2.0	30.4	3.6	2.1	31.7	3.5	2.3
10	60	32.3	2.9	2.8	32.4	2.8	2.8	32.5	2.8	2.8
	70	30.3	3.2	2.4	30.5	3.1	2.4	30.6	3.0	2.4
	80	28.3	3.5	2.0	28.5	3.4	2.1	28.8	3.3	2.1

NOTE: ALL CAPACITIES ARE NET (KBTUH) WITH INDOOR FAN HEAT ALREADY DEDUCTED AT 1250 BTUH/1000 CFM.

Multipliers for determining the performance with other indoor sections.

Air Handler	Coil	MBH	KW	COP
–	FC/MC/PC/UC60	1.00	1.00	1.00
–	FC/MC62	1.00	1.00	1.00
–	HC60	1.00	1.00	1.00
–	HD60	1.00	1.00	1.00
AHP/SHP60	–	0.98	1.02	0.98
AV/SV48	–	0.98	1.02	0.98
AV/SV60	–	0.98	1.02	0.98
F4FV060	–	0.98	1.02	0.98
F5FP060	–	0.98	1.02	0.98
MV16D	FC60C	0.98	1.00	1.00
MV20D	FC/MC60D	0.98	1.02	0.98
MV20D	FC/MC62D	1.00	0.99	1.01
MA16C	FC60C	1.00	1.00	1.00
MA20D	FC/MC60D	1.00	1.00	1.00
MV20D	FC/MC62D	0.98	1.02	0.98
MA20D	FC/MC62D	1.00	1.00	1.00

Variable Speed Furnace	Coil	MBH	KW	COP
(F,L)C8V*C16	FC/PC/UC60C	0.98	1.00	1.00
(F,L)C8V*C20	FC/PC/UC60C	0.98	1.01	0.99
FC9(C,V)*C16	FC/PC/UC60C	0.97	1.00	1.00
FC9(C,V)*C20	FC/PC/UC60C	0.98	1.00	1.00
FC9(C,V)*D20	FC/MC/PC/UC60D	0.98	1.01	0.99
(F,L)C8V*C20	FC/MC62D	0.98	1.01	0.99
FC9(C,V)*C20	FC/MC62D	0.98	1.00	1.00
FC9(C,V)*D20	FC/MC62D	0.98	1.01	0.99
C*9C*D20	FC/MC/PC60D	0.99	0.99	1.00

Variable Speed Furnace	Coil	MBH	KW	COP
C*9C*D20	FC/MC62D	1.00	1.02	0.98
C*(8,L)C*C16	FC/PC60C	0.99	1.00	0.99
C*(8,L)C*C20	FC/PC60C	0.99	1.01	0.98
C*9C*C16	FC/PC60C	1.00	0.99	1.00
C*9C*C20	FC/PC60C	1.00	0.99	1.01
C*9C*D20	HC60	1.00	1.03	0.97
C*(8,L)C*C16	HD60	0.99	0.95	1.04
C*(8,L)C*C20	HD60	0.99	0.96	1.03
C*9C*C16	HD60	0.99	0.94	1.05
C*9C*C20	HD60	0.99	0.94	1.05
C*9C*D20	HD60	0.99	0.95	1.05
C*(8,L)C*C16	UC60C	0.99	1.02	0.97
C*(8,L)C*C20	UC60C	0.99	1.03	0.96
C*9C*C16	UC60C	1.00	1.01	0.99
C*9C*C20	UC60C	1.00	1.01	0.99
C*9C*D20	UC60D	1.00	1.02	0.98
G*9V*D20	FC/MC/PC60D	0.99	0.99	1.00
G*9V*D20	FC/MC62D	1.00	1.02	0.98
G*9V*C16	FC/PC60C	1.00	0.99	1.00
G*9V*C20	FC/PC60C	1.00	0.99	1.01
G*9V*D20	HC60	1.00	1.03	0.97
G*9V*C16	HD60	0.99	0.94	1.05
G*9V*C20	HD60	0.99	0.94	1.05
G*9V*D20	HD60	0.99	0.95	1.05
G*9V*C16	UC60C	1.00	1.01	0.99
G*9V*C20	UC60C	1.00	1.01	0.99
G*9V*D20	UC60D	1.00	1.02	0.98

HEATING PERFORMANCE DATA

CONDENSING UNIT MODEL NO		CHJD60S21S1								
EVAPORATOR COIL MODEL NO		FC/MC62								
AIR TEMP. ENTERING OUTDOOR UNIT	AIR TEMP. ENTERING INDOOR COIL	ID CFM								
		1600			1800			2000		
		MBTUH	KW	C.O.P.	MBTUH	KW	C.O.P.	MBTUH	KW	C.O.P.
60	60	75.6	4.6	4.8	76.1	4.4	5.1	76.6	4.2	5.3
	70	72.9	5.1	4.2	73.4	4.9	4.4	73.8	4.6	4.7
	80	70.2	5.6	3.7	70.6	5.3	3.9	71.0	5.1	4.1
47	60	63.8	4.3	4.4	64.2	4.1	4.6	64.7	3.9	4.8
	70	61.4	4.8	3.8	61.8	4.6	4.0	62.2	4.4	4.2
	80	59.0	5.3	3.3	59.3	5.0	3.4	59.6	4.8	3.6
40	60	53.1	4.0	3.9	53.2	4.2	3.7	53.3	4.3	3.6
	70	48.9	4.4	3.3	49.3	4.6	3.1	49.6	4.8	3.0
	80	44.7	4.7	2.7	45.4	5.0	2.7	46.0	5.2	2.6
30	60	47.5	4.1	3.4	48.8	3.9	3.6	50.2	3.7	3.9
	70	46.6	4.5	3.0	47.3	4.4	3.2	48.1	4.2	3.4
	80	45.7	4.9	2.7	45.8	4.8	2.8	45.9	4.6	2.9
17	60	38.3	3.8	2.9	40.1	3.6	3.2	41.9	3.5	3.5
	70	36.8	4.0	2.7	38.4	4.0	2.8	40.0	3.9	3.0
	80	35.3	4.3	2.4	36.7	4.3	2.5	38.1	4.4	2.6
10	60	33.1	3.4	2.9	34.5	3.5	2.9	36.0	3.6	2.9
	70	33.2	3.9	2.5	34.0	3.9	2.5	34.7	3.9	2.6
	80	33.4	4.4	2.2	33.4	4.3	2.2	33.4	4.3	2.3

NOTE: ALL CAPACITIES ARE NET (KBTUH) WITH INDOOR FAN HEAT ALREADY DEDUCTED AT 1250 BTUH/1000 CFM.

Multipliers for determining the performance with other indoor sections.

Air Handler	Coil	MBH	KW	COP
MV20D	FC/MC62D	1.00	1.01	0.99
MA20D	FC/MC62D	1.00	1.00	1.00

Variable Speed Furnace	Coil	MBH	KW	COP
(F,L)C8V*C20	FC/MC62D	1.00	1.00	1.00
FC9(C,V)*C20	FC/MC62D	0.98	1.00	1.00
FC9(C,V)*D20	FC/MC62D	0.96	1.01	0.99
C*(8,L)C*C20	FC/MC62D	0.99	1.00	0.98
C*9C*C20	FC/MC62D	0.99	0.99	1.01
C*9C*D20	FC/MC62D	0.99	0.99	1.00
G*9V*C20	FC/MC62D	0.99	0.99	1.01
G*9V*D20	FC/MC62D	0.99	0.99	1.00