

SUBMITTAL DATA SHEET



**R-22 SPLIT SYSTEM HEAT PUMP UNITS
1.5 THRU 5 TONS
MODELS: 13 SEER CHJD18 THRU 60**

JOB NAME:		LOCATION:		
PURCHASER:		ORDER NO:		
ENGINEER:				
SUBMITTED TO:	FOR:	REF:	APPROVAL:	CONSTRUCTION:
SUBMITTED BY:		DATE:		
UNIT DESIGNATION:		SCHEDULE NO.	MODEL NO.	

PRODUCT DATA

Cooling Performance

Total Capacity _____ MBH
Outdoor Design Temp _____ °F

Electrical Data

Power Supply ____ / ____ / ____
Compressor Ampacity _____ AMPs
Total Unit Ampacity _____ AMPs
Power Input Req _____ KW
Minimum Wire Size _____ AWG
Overcurrent Device
 Fuses Circuit Breaker

Unit Weight

Unit Weight _____ LBS

DIMENSIONS - INCHES

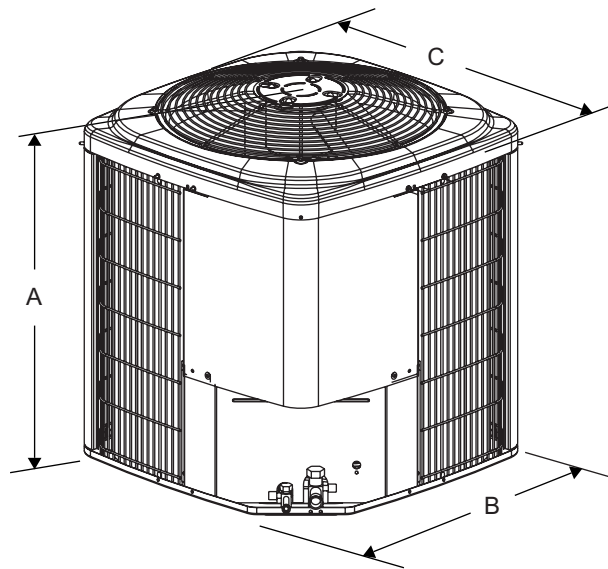

All dimensions are in inches. They are subject to change without notice. Certified dimensions will be provided upon request.

Unit Model	Dimensions (Inches)			Refrigerant Connection Service Valve Size	
	A ¹	B	C	Liquid	Vapor
18	28	34	34	3/8"	3/4"
24	32	34	34		
30	36	34	34		
36	40	34	34		7/8"
42	40	34	34		
48	40	34	34		
60	40	34	34	1-1/8"	

1. Including Fan Guard.

* Adapter fitting required for 1-1/8" line set.



FEATURES

- UL approval (units & accessories)
- CUL listed.
- Certified in accordance with the Unitary Small Equipment certification program, which the ARI Standard 210/240.
- 5-year limited parts warranty.
- 5-year limited warranty on the compressor.
- Copper tube aluminum fin coil.
- Internally protected compressor.
- Propeller type fan.
- Durable construction.
- Pre-painted steel cabinet.
- Factory wired and tested.
- Sweat refrigerant connections.
- Re-useable brass service valves.
- Easy access to electrical compartment.
- Liquid line filter dryer.
- PVC wire coated fan guard and 2" x 4" coil guard.
- 18 gauge G90 galvanized formed base pan.
- Condenser fan molex plug connector.

CLEARANCES

Service Access	24 Inches
All Other Sides	10 Inches
Above Unit	48 Inches
Below Unit	0 Inches

MATCHING AIR SIDE EQUIPMENT

Model No. _____
Submittal Form No. _____

FIELD INSTALLED ACCESSORIES

Start Assist Kit _____
Blower Time Delay _____
Hard Start Kits - _____
Low Temperature Cutout _____
Compressor Blanket _____
Add-on Fossil Fuel Control _____
Thermal Expansion Valve Kit _____
Outdoor Thermostat (2TD06700124) _____

NOTES:
