

TABULAR DATA SHEET

Outdoor Split System Air Conditioner 2.5 Thru 5 Tons

MODELS: TCGD30* THRU 60

13 SEER – R-410A, 3 PHASE

Physical and Electrical Data

MODEL		TCGD30 S43S1	TCGD36 S43S1	TCGD42 S43S1	TCGD48 S43S1	TCGD60 S43S1	TCGD30 S44S1	TCGD36 S44S1	TCGD42 S44S1	TCGD48 S44S1	TCGD60 S44S1
Unit Supply Voltage		208-230V, 3 ϕ , 60Hz					460V, 3 ϕ , 60Hz				
Normal Voltage Range ¹		187 to 252					432 to 532				
Minimum Circuit Ampacity		11.6	12.3	16.3	15.5	23.5	6.0	6.4	7.3	7.2	11.6
Max. Overcurrent Device Amps ²		15	20	25	25	40	15	15	15	15	20
Min. Overcurrent Device Amps ³		15	15	20	20	25	15	15	15	15	15
Compressor Type		Recip	Recip	Recip	Recip	Scroll	Recip	Recip	Recip	Recip	Scroll
Compressor Amps	Rated Load	8.1	8.6	11.8	11.2	17.6	4.2	4.5	5.2	5.1	8.6
	Locked Rotor	63	68	88	88	120	30	34	44	44	70
Crankcase Heater		No	No	No	No	No	No	No	No	No	No
Fan Motor Amps	Rated Load	1.4	1.5	1.5	1.5	1.5	0.8	0.8	0.8	0.8	0.8
	Fan Diameter Inches	17.5	22	22	22	22	17.5	22	22	22	22
Fan Motor	Rated HP	1/4	1/4	1/4	1/4	1/4	1/4	1/4	1/4	1/4	1/4
	Nominal RPM	1100	850	850	850	850	1100	850	850	850	850
	Nominal CFM	2050	3200	2950	2950	3600	2050	3200	2950	2950	3600
Coil	Face Area Sq. Ft.	9.6	13.07	14.16	14.16	18.68	9.6	13.07	14.16	14.16	18.68
	Rows Deep	1	1	1	1	1	1	1	1	1	1
	Fin / Inches	23	23	23	23	23	23	23	23	23	23
Liquid Line Set OD (Field Installed)		3/8	3/8	3/8	3/8	3/8	3/8	3/8	3/8	3/8	3/8
Vapor Line Set OD (Field Installed)		3/4	3/4	7/8	7/8	7/8	3/4	3/4	7/8	7/8	7/8
Unit Charge (Lbs. - Oz.) ⁴		3 - 14	4 - 9	4 - 5	4 - 9	5 - 6	3 - 14	4 - 9	4 - 5	4 - 9	5 - 6
Charge Per Foot, Oz.		0.62	0.62	0.67	0.67	0.67	0.62	0.62	0.67	0.67	0.67
Operating Weight Lbs.		131	145	173	173	195	131	145	173	173	195

1. Rated in accordance with ARI Standard 110, utilization range "A".

2. Dual element fuses or HACR circuit breaker. Maximum allowable overcurrent protection.

3. Dual element fuses or HACR circuit breaker. Minimum recommended overcurrent protection.

4. The Unit Charge is correct for the outdoor unit, matched indoor coil and 15 feet of refrigerant tubing. For tubing lengths other than 15 feet, add or subtract the amount of refrigerant, using the difference in length multiplied by the per foot value. If line exceeds 25 feet, you may refer to publications software 036-68001-001 for proper line sizing.

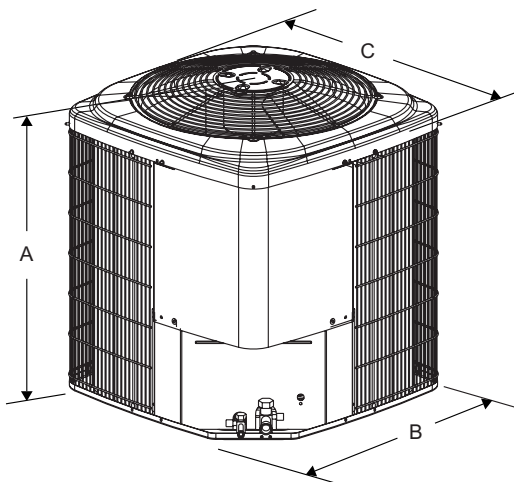

All dimensions are in inches. They are subject to change without notice. Certified dimensions will be provided upon request.

Unit Model	Dimensions (Inches)			Refrigerant Connection Service Valve Size	
	A ¹	B	C	Liquid	Vapor
30	28	23-1/2	23-1/2	3/8"	3/4"
36	28	29	29		
42	30	29	29		7/8"
48	30	29	29		
60	32	33-5/8	33-5/8		

1. Including Fan Guard.

System Charge for Various Matched Systems					
Outdoor Unit	TCGD30S4(3,4)S1	TCGD36S4(3,4)S1	TCGD42S4(3,4)S1	TCGD48S4(3,4)S1	TCGD60S4(3,4)S1
Required Orifice or TXV ^{1,2}	0.061/4F1	0.065/4G1	0.075/4G1	0.073/4H1	0.087/4J1
Factory Charge, lbs-oz	3 - 14	4 - 9	4 - 5	4 - 9	5 - 6
Indoor Coil ^{3,4}	Additional Charge, oz				
AHP30	0	-	-	-	-
AHP36	2	0	-	-	-
AHP42	-	0	0	-	-
AHP/SHP60	-	-	-	0	0
AHX30	0	-	-	-	-
AHX36	2	0	-	-	-
AHX42	-	8	2	-	-
AHX48	-	-	-	0	-
AHX60	-	-	-	-	4
F4FP024	-	-	-	-	-
F4FP036	-	-	-	-	-
F4FP040	0	-	-	-	-
F5FP048	-	8	2	4	-
F5FP060	-	-	-	0	0
F6FP030	0	-	-	-	-
F6FP036	0	-	-	-	-
F6FP042	-	8	2	-	-
F6FP048	-	-	TXV + 2	0	-
F6FP060	-	-	-	-	4
FC/MC/PC32	0	-	-	-	-
FC/MC/PC35	0	-	-	-	-
FC/MC/PC37	2	0	-	-	-
FC/MC/PC43	2	0	0	-	-
FC/MC/PC48	-	8	2	4	-
FC/MC/PC60	-	-	-	0	0
FC/MC62	-	-	-	-	4
HC36	0	-	-	-	-
HC42	2	0	0	-	-
HC60	-	-	-	-	0
UC48	-	8	2	4	-
UC60	-	-	-	0	0

FOOTNOTES:

1. For applications requiring a TXV use 1TVM series kit.
2. Approved orifice shipped with outdoor unit.
3. Systems matched with furnace or air handlers not equipped with blower-off delays may require blower Time Delay Kit 2FD06700224.
4. PC coils cannot be used in downflow or horizontal applications. FC coils cannot be used in horizontal applications.

PROCEDURES:

1. Unit factory charge listed on the unit nameplate includes refrigerant for the condenser, the smallest evaporator and 15 feet of interconnecting line tubing.
2. Verify the TXV and additional charge required for specific evaporator coil in the system using the above table.
3. Additional charge for the amount of interconnecting line tubing greater than 15 feet at the rate specified in Physical and Electrical Data Table.
4. For orifice or TXV matches requiring additional charge, the refrigerant needs to be weighed in for specific coil match and lineset length.
5. Permanently mark the unit nameplate with the total system charge. Total System Charge = Base Charge (as shipped) + adder for evaporator + adder for line set.

