



HEATING & AIR CONDITIONING

TECHNICAL GUIDE

COMPETITOR SERIES

SPLIT-SYSTEM

HEAT PUMPS

13 SEER – R-410A

MODELS:

THRD18 THRU 60

(1.5 THRU 5 NOMINAL TONS, 1 PHASE)



Due to continuous product improvement, specifications are subject to change without notice.

Visit us on the web at www.york.com

Additional rating information can be found at www.ahridirectory.org

WARRANTY

Standard 5-year limited parts warranty.
Standard 5-year limited compressor warranty.

Extended 10-year limited parts warranty when product is registered online within 90 days of purchase for replacement or closing for new home construction.

DESCRIPTION

The 13 SEER Series unit is the outdoor part of a versatile climate system. It is designed with a matching indoor coil component from Johnson Controls Unitary Products. Available for typical applications this climate system is supported with accessories and documents to serve specific functions.

FEATURES

- **QUALITY CONDENSER COILS** - The coil is constructed of copper tubing and enhanced aluminum fins for increased efficiency and corrosion protection.
- **PROTECTED COMPRESSOR** - The compressor is internally protected against high pressure, temperature, and externally by a factory installed high pressure switch. This is accomplished by the simultaneous operation of high pressure relief valve and a temperature sensor which protects the compressor if undesirable operating conditions occur. A liquid line filter-drier further protects the compressor.
- **DURABLE FINISH** - The cabinet is made of pre-painted steel. The pre-treated galvanized steel provides a better paint to steel bond, which resists corrosion and rust creep. Special primer formulas and matted-textured finish insure less fading when exposed to sunlight.
- **LOWER INSTALLED COST** - Installation time and costs are reduced by easy power and control wiring connections. Available in sweat connect models only. The unit contains enough refrigerant for matching indoor coils and 15 feet of interconnecting piping. The small base dimension means less space is required on the ground or roof.
- **TOP DISCHARGE** - The warm air from the top mounted fan is blown up away from the structure and any landscaping. This allows compact location on multi-unit applications.
- **LOW OPERATING SOUND LEVEL** - The upward air flow carries the normal operating noise away from the living area. The rigid top panel effectively isolates any motor sound. Isolator mounted compressor and the rippled fins of the condenser coil muffle the normal fan motor and compressor operating sounds.
- **LOW MAINTENANCE** - Long life permanently lubricated motor-bearings need no annual servicing.
- **EASY SERVICE ACCESS** - Fully exposed refrigerant connections, and a single panel covering the electrical controls make for easy servicing of the unit.
- **SECURED SERVICE VALVES** - Secured re-usable service valves are provided on both the liquid and vapor sweat connections for ease of evacuating and charging.
- **U.L. and C.U.L. listed** - approved for outdoor application.
- **Agency Listed** - U.L. and C.U.L. listed - approved for outdoor application. The unit is certified in accordance with the Unitary Small Equipment certification program, which is based on ARI Standard 210/240.

Physical and Electrical Data

MODEL	THRD18 S41S1	THRD24 S41S1	THRD30 S41S1	THRD36 S41S1	THRD42 S41S1	THRD48 S41S1	THRD60 S41S1
Unit Supply Voltage	208-230V, 1 ϕ , 60Hz						
Normal Voltage Range ¹	187 to 252						
Minimum Circuit Ampacity	11.2	12.4	14.9	19.9	21.1	23.0	37.4
Max. Overcurrent Device Amps ²	15	20	25	30	35	40	60
Min. Overcurrent Device Amps ³	15	15	15	20	25	25	40
Compressor Type	Recip	Recip	Recip	Recip	Recip	Recip	Scroll
Compressor Amps	Rated Load	8.3	9.3	11.3	14.7	15.7	28.8
	Locked Rotor	43.0	43.0	54.0	74.0	88.0	150.0
Crankcase Heater	Yes	Yes	Yes	Yes	Yes	Yes	No
Fan Motor Amps	Rated Load	0.8	0.8	0.8	1.5	1.5	1.5
Fan Diameter Inches	18	18	22	24	24	24	24
Fan Motor	Rated HP	1/8	1/8	1/8	1/4	1/4	1/4
	Nominal RPM	1075	1075	1075	850	850	850
	Nominal CFM	2000	2000	2500	3500	3500	2358
Coil	Face Area Sq. Ft.	9.3	9.3	12.8	15.7	15.7	23.6
	Rows Deep	1	1	1	1	1	2
	Fin / Inches	18	18	18	22	22	18
Liquid Line Set OD (Field Installed)	3/8	3/8	3/8	3/8	3/8	3/8	3/8
Vapor Line Set OD (Field Installed)	3/4	3/4	3/4	3/4	7/8	7/8	7/8
Unit Charge (Lbs. - Oz.) ⁴	5 - 6	5 - 8	7 - 8	7 - 8	8 - 8	9 - 1	13 - 6
Charge Per Foot, Oz.	0.62	0.62	0.62	0.62	0.67	0.67	0.67
Operating Weight Lbs.	145	145	176	193	198	248	290

1. Rated in accordance with ARI Standard 110, utilization range "A".
2. Dual element fuses or HACR circuit breaker. Maximum allowable overcurrent protection.
3. Dual element fuses or HACR circuit breaker. Minimum recommended overcurrent protection.
4. The Unit Charge is correct for the outdoor unit, matched indoor coil and 15 feet of refrigerant tubing. For tubing lengths other than 15 feet, add or subtract the amount of refrigerant, using the difference in length multiplied by the per foot value.

All dimensions are in inches. They are subject to change without notice. Certified dimensions will be provided upon request.

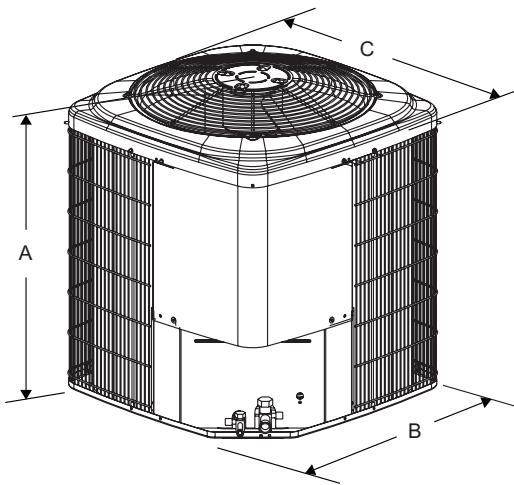

Unit Model	Dimensions (Inches)			Refrigerant Connection Service Valve Size	
	A ¹	B	C	Liquid	Vapor
18	28	23-1/2	23-1/2	3/8"	3/4"
24	28	23-1/2	23-1/2		
30	28	29	29		
36	28	34	34		
42	28	34	34		
48	40	34	34	7/8"	
60	40	34	34		

1. Including Fan Guard.

System Charge for Various Matched Systems							
Outdoor Unit	THRD18S41S1	THRD24S41S1	THRD30S41S1	THRD36S41S1	THRD42S41S1	THRD48S41S1	THRD60S41S1
Required Orifice or TXV ^{1,2}	.049/4F1	.055/4G1	.060/4G1	.067/4H1	.075/4J1	.078, .081/4K1	4K1
Factory Charge, lbs-oz	5 - 6	5 - 8	7 - 8	7 - 8	8 - 8	9 - 1	13 - 1
Indoor Coil ^{3,4}	Additional Charge, Oz						
AHX18	.049 + 0	–	–	–	–	–	–
AHX24	.049 + 13	.055 + 13	–	–	–	–	–
AHX30	–	.055 + 18	–	–	–	–	–
AHX36	–	–	.060 + 4	.067 + 6	–	–	–
AHX42	–	–	–	–	.075 + 0	–	–
AHX48	–	–	–	–	.075 + 2	.081 + 0	–
AHX60	–	–	–	–	–	.078 + 8	TXV + 0
AV*24	.049 + 2	.055 + 0	–	–	–	–	–
AV*36	–	–	.060 + 4	.067 + 6	–	–	–
AV*48	–	–	–	–	.075 + 2	.081 + 0	–
AV*60	–	–	–	–	.075 + 2	.081 + 0	–
F6FP018	.049 + 0	–	–	–	–	–	–
F6FP024	.049 + 2	.055 + 0	–	–	–	–	–
F6FP030	–	–	.060 + 0	–	–	–	–
F6FP036	–	–	.060 + 0	.067 + 0	–	–	–
F6FP042	–	–	–	–	.075 + 0	–	–
F6FP048	–	–	–	–	.075 + 2	.081 + 0	–
F6FP060	–	–	–	–	–	.078 + 8	TXV + 0
FC/MC/PC/UC18	.049 + 0	–	–	–	–	–	–
FC/MC/PC/UC24	.049 + 5	.055 + 3	–	–	–	–	–
FC/MC/PC/UC30	.049 + 5	.055 + 3	–	–	–	–	–
FC/MC/PC/UC32	–	–	.060 + 0	–	–	–	–
FC/MC/PC/UC35	–	–	.060 + 0	–	–	–	–
FC/MC/PC/UC37	–	–	.060 + 4	–	–	–	–
FC/MC/PC/UC43	–	–	.060 + 4	.067 + 6	–	–	–
FC/MC/PC/UC48	–	–	–	–	.075 + 0	–	–
FC/MC/PC/UC60	–	–	–	–	.075 + 2	.081 + 0	–
FC/PC62	–	–	–	–	–	.078 + 8	TXV + 0
HC30A3X	.049 + 11	.055 + 9	–	–	–	–	–
HC42C3X	–	–	.060 + 4	.067 + 6	–	–	–
HC60D3X	–	–	–	–	.075 + 2	–	–

FOOTNOTES:

1. For applications requiring a TXV use 1TVM series kit.
2. Approved orifice shipped with outdoor unit.
3. Systems matched with furnace or air handlers not equipped with blower-off delays may require blower Time Delay Kit 2FD06700224.
4. PC coils cannot be used in downflow or horizontal applications. FC coils cannot be used in horizontal applications.

PROCEDURES:

1. Unit factory charge listed on the unit nameplate includes refrigerant for the condenser, the smallest evaporator and 15 feet of interconnecting line tubing.
2. Verify the TXV and additional charge required for specific evaporator coil in the system using the above table.
3. Additional charge for the amount of interconnecting line tubing greater than 15 feet at the rate specified in Physical and Electrical Data Table.
4. For orifice or TXV matches requiring additional charge, the refrigerant needs to be weighed in for specific coil match and lineset length.
5. Permanently mark the unit nameplate with the total system charge. Total System Charge = Base Charge (as shipped) + adder for evaporator + adder for line set.

COOLING CAPACITY - With Air Handler Coils

UNIT MODEL	AIR HANDLER		COIL MODEL ¹	COOLING				
	MODEL	W		RATED CFM	NET MBH		SEER	EER
					TOTAL	SENS.		
13 SEER HP WITH MV - VARIABLE SPEED								
THRD18S41S1	MV12B	17	FC/MC18B	655	18.0	13.5	13.00	11.20
	MV12B	17	FC/MC24B	655	18.0	13.5	13.00	11.45
	MV12B	17	FC/MC30B	655	18.0	13.5	13.00	11.45
THRD24S41S1	MV12B	17	FC/MC24B	770	23.0	17.5	13.00	11.20
	MV12B	17	FC/MC30B	770	23.0	17.5	13.00	11.20
THRD30S41S1	MV16C	21	FC/MC35C	1095	30.0	21.7	13.00	11.50
	MV12B	17	FC/MC43B	1050	30.0	21.7	13.00	11.65
	MV16C	21	FC/MC43C	1095	30.0	21.7	13.00	11.70
THRD36S41S1	MV16C	21	FC/MC35C	1215	34.2	25.0	13.00	11.20
	MV16C	21	FC/MC43C	1215	35.0	25.6	13.00	11.60
THRD42S41S1	MV16C	21	FC/MC48C	1400	40.5	31.6	13.00	11.75
	MV20D	24	FC/MC48D	1430	40.5	31.6	13.00	11.80
	MV16C	21	FC/MC60C	1400	40.5	31.1	13.00	11.85
	MV20D	24	FC/MC60D	1430	40.5	31.6	13.00	11.90
THRD48S41S1	MV20D	24	FC/MC60D	1595	47.0	35.3	13.00	11.80
	MV20D	24	FC/MC62D	1595	47.5	35.5	13.00	11.80
THRD60S41S1	MV20D	24	FC/MC62D	1800	54.5	43.0	13.00	11.20
13 SEER HP WITH AV - VARIABLE SPEED								
THRD18S41S1	AV*24	17	—	595	18.0	13.5	13.00	11.20
THRD24S41S1	AV*24	17	—	815	23.6	18.0	13.00	11.30
THRD30S41S1	AV*36	21	—	1005	30.0	21.7	13.00	11.45
THRD36S41S1	AV*36	21	—	1230	35.0	25.6	13.00	11.60
THRD42S41S1	AV*48	24	—	1440	40.5	31.6	13.00	11.80
	AV*60	24	—	1400	40.5	31.6	13.00	11.75
THRD48S41S1	AV*48	24	—	1605	47.0	35.3	13.00	11.70
	AV*60	24	—	1600	47.0	35.3	13.00	11.65
13 SEER HP WITH AHX / F6FP								
THRD18S41S1	AHX18	17	—	630	18.0	13.9	13.65	11.65
	AHX24	17	—	590	18.0	13.8	13.75	11.65
	F6FP18	17	—	600	18.0	13.5	13.00	11.20
	F6FP24	17	—	600	18.0	13.5	13.00	11.20
THRD24S41S1	AHX24	17	—	800	24.0	18.3	13.70	11.75
	AHX30	17	—	820	24.0	19.0	13.95	12.00
	F6FP24	17	—	800	23.6	18.0	13.00	11.30
THRD30S41S1	AHX36	21	—	1005	30.0	22.6	13.55	12.05
	F6FP30	21	—	990	30.0	21.7	13.00	11.45
	F6FP36	21	—	1000	30.0	21.7	13.00	11.45
THRD36S41S1	AHX36	21	—	1200	35.0	25.6	14.00	11.85
	F6FP36	21	—	1190	34.2	25.0	13.00	11.20
THRD42S41S1	AHX42	21	—	1395	41.0	31.6	14.10	12.20
	AHX48	24	—	1445	41.0	32.4	14.25	12.20
	F6FP42	24	—	1430	40.5	31.6	13.00	11.80
	F6FP48	24	—	1400	40.5	31.6	13.00	11.80
THRD48S41S1	AHX48	24	—	1660	46.5	35.2	13.45	11.85
	AHX60	24	—	1600	47.0	35.5	13.60	11.75
	F6FP48	24	—	1600	47.0	35.3	13.00	11.70
	F6FP60	24	—	1600	47.5	35.5	13.00	11.80
THRD60S41S1	AHX60	24	—	1800	54.5	43.0	13.00	11.20
	F6FP60	24	—	1800	54.5	43.0	13.00	11.20

Rated in accordance with DOE test procedures (Federal Register 12-27-79 and 3-18-88) and ARI Standards 210.

Cooling MBH based on 80°F entering air temperature, 50% RH, and rated air flow.

EER (Energy Efficiency Ratio) is the total cooling output in BTU's at 95°F outdoor ambient divided by the total electric power in watt-hours at those conditions.

SEER (Seasonal Energy Efficiency Ratio) is the total cooling output in BTU's during a normal annual usage period for cooling divided by the total electric power input in watt-hours during the same period.

1. MC coils available with a factory installed horizontal drain pan. See price pages for specific model number.

— = Not applicable.

COOLING CAPACITY - Upflow, Downflow & Horizontal Furnaces and Coils

UNIT MODEL	FURNACE**		COIL MODEL	COOLING				
	CFM RANGE (Min.-max.)	W		RATED CFM	NET MBH		SEER ¹	EER
					TOTAL	SENS.		
THRD60S41S1	1600 - 2000	21,24	FC/MC62	1850	54.0	42.5	13.00	11.00

1. Requires a 2FD06700224 Blower Time Delay unless a standard furnace is equipped with one.

** Refer to Quick Selection Chart for specific furnace match-up.

COOLING CAPACITY - With High Efficiency Motor Furnaces

UNIT MODEL	FURNACE MODEL	COIL MODEL ¹	W	COOLING				
				RATED CFM	Net MBH		SEER	EER
					TOTAL	SENS.		
13 SEER HP WITH VARIABLE SPEED FURNACES²								
THRD18S41S1	T*(8,L)X*A12	FC/MC/PC/UC24A	14	600	18.0	13.5	13.00	11.00
	T*(8,L)X*B12	FC/MC/PC/UC24B	17	580	18.0	13.5	13.00	11.00
	T*9X*B12	FC/MC/PC/UC24B	17	600	18.0	13.5	13.00	11.00
	T*(8,L)X*A12	FC/MC/PC/UC30A	14	600	18.0	13.5	13.00	11.00
	T*(8,L)X*B12	FC/MC/PC/UC30B	17	580	18.0	13.5	13.00	11.00
	T*9X*B12	FC/MC/PC/UC30B	17	600	18.0	13.5	13.00	11.00
	T*(8,L)X*A12	HC30	14	600	18.0	13.5	13.00	11.00
	C*(8,L)C*A12	FC/MC/PC/UC24A	14	600	18.0	13.5	13.00	11.00
	C*(8,L)C*B12	FC/MC/PC/UC24B	17	580	18.0	13.5	13.00	11.00
	(C*9C/T*9V)*B12	FC/MC/PC/UC24B	17	600	18.0	13.5	13.00	11.00
	C*(8,L)C*A12	FC/MC/PC/UC30A	14	600	18.0	13.5	13.00	11.00
	C*(8,L)C*B12	FC/MC/PC/UC30B	17	580	18.0	13.5	13.00	11.00
	(C*9C/T*9V)*B12	FC/MC/PC/UC30B	17	600	18.0	13.5	13.00	11.00
	C*(8,L)C*A12	HC30	14	600	18.0	13.5	13.00	11.00
THRD24S41S1	T*(8,L)X*A12	FC/MC/PC/UC24A	14	815	23.6	18.0	13.00	11.00
	T*(8,L)X*B12	FC/MC/PC/UC24B	17	775	23.6	18.0	13.00	11.10
	T*9X*B12	FC/MC/PC/UC24B	17	760	23.6	18.0	13.00	11.00
	T*(8,L)X*A12	FC/MC/PC/UC30A	14	815	23.6	18.0	13.00	11.00
	T*(8,L)X*B12	FC/MC/PC/UC30B	17	775	23.6	18.0	13.00	11.10
	T*9X*B12	FC/MC/PC/UC30B	17	760	23.6	18.0	13.00	11.00
	T*(8,L)X*A12	HC30	14	815	23.6	18.0	13.00	11.00
	C*(8,L)C*A12	FC/MC/PC/UC24A	14	815	23.6	18.0	13.00	11.00
	C*(8,L)C*B12	FC/MC/PC/UC24B	17	775	23.6	18.0	13.00	11.10
	(C*9C/T*9V)*B12	FC/MC/PC/UC24B	17	760	23.6	18.0	13.00	11.00
	C*(8,L)C*A12	FC/MC/PC/UC30A	14	815	23.6	18.0	13.00	11.00
	C*(8,L)C*B12	FC/MC/PC/UC30B	17	775	23.6	18.0	13.00	11.10
	(C*9C/T*9V)*B12	FC/MC/PC/UC30B	17	760	23.6	18.0	13.00	11.00
	C*(8,L)C*A12	HC30	14	815	23.6	18.0	13.00	11.00
THRD30S41S1	T*(8,L)X*B12	FC/MC/PC/UC43B	17	960	30.0	21.7	13.00	11.25
	T*9X*B12	FC/MC/PC/UC43B	17	1000	30.0	21.7	13.00	11.15
	T*(8,L)X*C16	FC/MC/PC/UC43C	21	1000	30.0	21.7	13.00	11.40
	T*9X*C16	FC/MC/PC/UC43C	21	995	30.0	21.7	13.00	11.25
	T*(8,L)X*C16	HC42	21	1000	30.0	21.7	13.00	11.40
	T*9X*C16	HC42	21	995	30.0	21.7	13.00	11.25
	C*(8,L)C*B12	FC/MC/PC/UC43B	17	960	30.0	21.7	13.00	11.25
	(C*9C/T*9V)*B12	FC/MC/PC/UC43B	17	1000	30.0	21.7	13.00	11.15
	C*(8,L)C*C16	FC/MC/PC/UC43C	21	1000	30.0	21.7	13.00	11.40
	(C*9C/T*9V)*C16	FC/MC/PC/UC43C	21	995	30.0	21.7	13.00	11.25
	C*(8,L)C*C16	HC42	21	1000	30.0	21.7	13.00	11.40
	(C*9C/T*9V)*C16	HC42	21	995	30.0	21.7	13.00	11.25

For Notes See Page 6.

COOLING CAPACITY - With High Efficiency Motor Furnaces (Continued)

UNIT MODEL	FURNACE MODEL	COIL MODEL ¹	W	COOLING				
				RATED CFM	Net MBH		SEER	EER
					TOTAL	SENS.		
13 SEER HP WITH VARIABLE SPEED FURNACES²								
THRD36S41S1	T*(8,L)X*C16	FC/MC/PC/UC43C	21	1200	34.2	25.0	13.00	11.00
	T*9X*C16	FC/MC/PC/UC43C	21	1175	34.2	25.0	13.00	11.00
	T*(8,L)X*C20	FC/MC/PC/UC43C	21	1270	34.2	25.0	13.00	11.00
	T*9X*C20	FC/MC/PC/UC43C	21	1270	34.2	25.0	13.00	11.00
	T*(8,L)X*C16	HC42	21	1200	34.2	25.0	13.00	11.00
	T*9X*C16	HC42	21	1175	34.2	25.0	13.00	11.00
	T*(8,L)X*C20	HC42	21	1270	34.2	25.0	13.00	11.00
	T*9X*C20	HC42	21	1270	34.2	25.0	13.00	11.00
	C*(8,L)C*C16	FC/MC/PC/UC43C	21	1200	34.2	25.0	13.00	11.00
	(C*9C/T*9V)*C16	FC/MC/PC/UC43C	21	1175	34.2	25.0	13.00	11.00
	C*(8,L)C*C20	FC/MC/PC/UC43C	21	1270	34.2	25.0	13.00	11.00
	(C*9C/T*9V)*C20	FC/MC/PC/UC43C	21	1270	34.2	25.0	13.00	11.00
	C*(8,L)C*C16	HC42	21	1200	34.2	25.0	13.00	11.00
	(C*9C/T*9V)*C16	HC42	21	1175	34.2	25.0	13.00	11.00
C*(8,L)C*C20	HC42	21	1270	34.2	25.0	13.00	11.00	
(C*9C/T*9V)*C20	HC42	21	1270	34.2	25.0	13.00	11.00	
THRD42S41S1	T*(8,L)X*C16	FC/MC/PC/UC48C	21	1430	40.5	31.6	13.00	11.50
	T*9X*C16	FC/MC/PC/UC48C	21	1385	40.5	31.6	13.00	11.30
	T*(8,L)X*C20	FC/MC/PC/UC48C	21	1370	40.5	31.6	13.00	11.60
	T*9X*C20	FC/MC/PC/UC48C	21	1445	40.5	31.6	13.00	11.40
	T*9X*D20	FC/MC/PC/UC48D	24	1435	40.5	31.6	13.00	11.45
	T*(8,L)X*C16	FC/PC/UC60C	21	1430	40.5	31.6	13.00	11.55
	T*9X*C16	FC/PC/UC60C	21	1385	40.5	31.6	13.00	11.35
	T*(8,L)X*C20	FC/PC/UC60C	21	1370	40.5	31.6	13.00	11.65
	T*9X*C20	FC/PC/UC60C	21	1445	40.5	31.6	13.00	11.50
	T*9X*D20	FC/MC/PC/UC60D	24	1435	40.5	31.6	13.00	11.60
	T*9X*D20	HC60	24	1435	40.5	31.6	13.00	11.60
	C*(8,L)C*C16	FC/MC/PC/UC48C	21	1430	40.5	31.6	13.00	11.50
	(C*9C/T*9V)*C16	FC/MC/PC/UC48C	21	1385	40.5	31.6	13.00	11.30
	(C*9C/T*9V)*C16	FC/MC/PC/UC48C	21	1385	40.5	31.6	13.00	11.30
	C*(8,L)C*C20	FC/MC/PC/UC48C	21	1370	40.5	31.6	13.00	11.60
	(C*9C/T*9V)*C20	FC/MC/PC/UC48C	21	1445	40.5	31.6	13.00	11.40
	(C*9C/T*9V)*D20	FC/MC/PC/UC48D	24	1435	40.5	31.6	13.00	11.45
	C*(8,L)C*C16	FC/PC/UC60C	21	1430	40.5	31.6	13.00	11.55
	(C*9C/T*9V)*C16	FC/PC/UC60C	21	1385	40.5	31.6	13.00	11.35
	C*(8,L)C*C20	FC/PC/UC60C	21	1370	40.5	31.6	13.00	11.65
(C*9C/T*9V)*C20	FC/PC/UC60C	21	1445	40.5	31.6	13.00	11.50	
(C*9C/T*9V)*D20	FC/MC/PC/UC60D	24	1435	40.5	31.6	13.00	11.60	
(C*9C/T*9V)*D20	HC60	24	1435	40.5	31.6	13.00	11.60	
THRD48S41S1	T*(8,L)X*C20	FC/MC62D	24	1670	47.0	35.3	13.00	11.60
	T*9X*C20	FC/MC62D	24	1605	47.0	35.3	13.00	11.50
	T*9X*D20	FC/MC62D	24	1595	47.0	35.3	13.00	11.40
	C*(8,L)C*C20	FC/MC62D	24	1670	47.0	35.3	13.00	11.60
	(C*9C/T*9V)*C20	FC/MC62D	24	1605	47.0	35.3	13.00	11.50
	(C*9C/T*9V)*D20	FC/MC62D	24	1595	47.0	35.3	13.00	11.40
THRD60S41S1	T*(8,L)X*C20	FC/MC62D	24	1750	54.0	42.5	13.00	11.00
	T*9X*C20	FC/MC62D	24	1650	53.0	41.0	13.00	11.00
	T*9X*D20	FC/MC62D	24	1615	53.5	41.5	13.00	11.00
	C*(8,L)C*C20	FC/MC62D	24	1750	54.0	42.5	13.00	11.00
	(C*9C/T*9V)*C20	FC/MC62D	24	1650	53.0	41.0	13.00	11.00
	(C*9C/T*9V)*D20	FC/MC62D	24	1615	53.5	41.5	13.00	11.00

1. MC coils available with a factory installed horizontal drain pan. See price pages for specific model number.

2. Variable speed furnaces have B.O.D (Blower on Delay) standard.

HEATING PERFORMANCE - With Air Handler

UNIT MODEL	AIR HANDLER	COIL ¹ MODEL	ARI HEATING ²						
			47°F			17°F			HSPF
			MBH	COP	KW	MBH	COP	KW	STD
13 SEER HP WITH MV - VARIABLE SPEED									
THRD18S41S1	MV12B	FC/MC18B	17.6	3.36	1.43	9.6	2.28	1.14	7.70
	MV12B	FC/MC24B	17.6	3.36	1.43	9.6	2.28	1.14	7.70
	MV12B	FC/MC30B	17.6	3.36	1.43	9.6	2.28	1.14	7.70
THRD24S41S1	MV12B	FC/MC24B	23.0	3.74	1.66	13.4	2.62	1.32	8.20
	MV12B	FC/MC30B	23.0	3.74	1.66	13.4	2.62	1.32	8.20
THRD30S41S1	MV16C	FC/MC35C	27.4	3.58	2.05	14.0	2.46	1.56	8.20
	MV12B	FC/MC43B	28.0	3.70	2.02	14.0	2.46	1.56	8.20
	MV16C	FC/MC43C	28.0	3.70	2.02	14.0	2.46	1.56	8.20
THRD36S41S1	MV16C	FC/MC43C	33.0	3.70	2.53	17.9	2.38	2.01	8.00
	MV16C	FC/MC48C	33.0	3.70	2.53	17.9	2.38	2.01	8.00
THRD42S41S1	MV16C	FC/MC48C	40.0	3.95	2.64	23.4	2.76	2.17	8.75
	MV20D	FC/MC48D	40.0	3.95	2.64	23.4	2.76	2.17	8.75
	MV16C	FC/MC60C	40.5	4.00	2.64	23.4	2.76	2.17	8.75
	MV20D	FC/MC60D	40.5	4.00	2.64	23.4	2.76	2.17	8.75
THRD48S41S1	MV20D	FC/MC60D	46.0	4.00	3.10	27.0	2.78	1.82	8.20
	MV20D	FC/MC62D	46.0	4.00	3.10	27.0	2.78	1.82	8.20
THRD60S41S1	MV20D	FC/MC62D	56.5	3.54	4.04	35.2	2.46	3.55	8.00
13 SEER HP WITH AV - VARIABLE SPEED									
THRD18S41S1	AV*24	—	17.6	3.36	1.43	9.6	2.28	1.14	7.70
THRD24S41S1	AV*24	—	23.0	3.74	1.66	13.4	2.62	1.32	8.20
THRD30S41S1	AV*36	—	27.4	3.58	2.05	14.0	2.46	1.56	8.20
THRD36S41S1	AV*36	—	32.0	3.50	2.53	17.9	2.38	2.01	8.00
THRD42S41S1	AV*48	—	40.5	3.95	2.64	23.4	2.76	2.17	8.75
	AV*60	—	40.5	3.95	2.64	23.4	2.76	2.17	8.75
THRD48S41S1	AV*48	—	46.0	4.00	3.10	27.0	2.78	1.82	8.20
	AV*60	—	46.0	4.00	3.10	27.0	2.78	1.82	8.20
13 SEER HP WITH AHX / F6FP									
THRD18S41S1	AHX18	—	17.8	3.36	1.43	9.6	2.28	1.14	7.95
	AHX24	—	17.9	3.46	1.52	10.4	2.46	1.24	7.95
	F6FP18	—	17.6	3.36	1.43	9.6	2.28	1.14	7.70
	F6FP24	—	17.6	3.36	1.43	9.6	2.28	1.14	7.70
THRD24S41S1	AHX24	—	23.0	3.80	1.77	13.3	2.64	1.48	8.60
	AHX30	—	23.4	3.88	1.77	13.5	2.68	1.48	8.80
	F6FP24	—	23.0	3.74	1.66	13.4	2.62	1.32	8.20
THRD30S41S1	AHX36	—	27.8	3.58	2.05	14.0	2.46	1.56	8.45
	F6FP30	—	27.4	3.58	2.05	14.0	2.46	1.56	8.20
	F6FP36	—	27.4	3.58	2.05	14.0	2.46	1.56	8.20
THRD36S41S1	AHX36	—	32.6	3.50	2.53	17.9	2.38	2.01	8.50
	F6FP36	—	32.0	3.50	2.53	17.9	2.38	2.01	8.00
THRD42S41S1	AHX42	—	39.5	3.98	2.91	23.0	2.82	2.39	9.40
	AHX48	—	39.5	3.95	2.64	23.4	2.76	2.17	9.40
	F6FP42	—	40.0	3.95	2.64	23.4	2.76	2.17	8.75
	F6FP48	—	40.0	3.95	2.64	23.4	2.76	2.17	8.75
THRD48S41S1	AHX48	—	45.5	4.00	3.10	27.0	2.78	1.82	8.35
	AHX60	—	46.0	3.96	3.40	26.4	2.76	2.80	8.40
	F6FP48	—	46.0	4.00	3.10	27.0	2.78	1.82	8.20
	F6FP60	—	46.0	4.00	3.10	27.0	2.78	1.82	8.20
THRD60S41S1	AHX60	—	56.5	3.54	4.04	35.2	2.46	3.55	8.00
	F6FP60	—	56.5	3.54	4.04	35.2	2.46	3.55	8.00

1. Rated CFM same as for cooling.

2. Heating MBH based on ARI standards of 70° DB entering indoor air, 72% RH outdoor air with 25 feet of interconnecting piping and no supplemental electric heat operation.

CP equals MBH output divided by (total KW input x 3.412).

HSPF (Heating Seasonal Performance Factor) is the total heating output during a normal annual usage period for heating divided by the total electric power input during the same period.

— = Not Applicable.

HEATING PERFORMANCE - Upflow, Downflow, and Horizontal Furnaces and Coils

UNIT MODEL	COIL ¹ MODEL	ARI HEATING ²						
		47°F			17°F			HSPF
		MBH	COP	KW	MBH	COP	KW	STD
THRD60S41S1	FC/MC62	56.5	3.48	4.76	35.4	2.42	4.29	8.00

1. Rated CFM same as for cooling.

2. Heating MBH based on ARI standards of 70° DB entering indoor air, 72% RH outdoor air with 25 feet of interconnecting piping and no supplemental electric heat operation.

CP equals MBH output divided by (total KW input x 3.412).

HSPF (Heating Seasonal Performance Factor) is the total heating output during a normal annual usage period for heating divided by the total electric power input during the same period.

— = Not Applicable.

HEATING CAPACITY - With High Efficiency Motor Furnaces

UNIT MODEL	VARIABLE SPEED FURNACE	COIL ¹ MODEL	ARI HEATING ²						
			47°F			17°F			HSPF
			MBH	COP	KW	MBH	COP	KW	STD
13 SEER HP WITH VARIABLE SPEED FURNACES³									
THRD18S41S1	T*(8,L)X*A12	FC/MC/PC/UC24A	17.6	3.36	1.43	9.6	2.28	1.14	7.7
	T*(8,L)X*B12	FC/MC/PC/UC24B	17.6	3.36	1.43	9.6	2.28	1.14	7.7
	T*9X*B12	FC/MC/PC/UC24B	17.6	3.36	1.43	9.6	2.28	1.14	7.7
	T*(8,L)X*A12	FC/MC/PC/UC30A	17.6	3.36	1.43	9.6	2.28	1.14	7.7
	T*(8,L)X*B12	FC/MC/PC/UC30B	17.6	3.36	1.43	9.6	2.28	1.14	7.7
	T*9X*B12	FC/MC/PC/UC30B	17.6	3.36	1.43	9.6	2.28	1.14	7.7
	T*(8,L)X*A12	HC30	17.6	3.36	1.43	9.6	2.28	1.14	7.7
	C*(8,L)C*A12	FC/MC/PC/UC24A	17.6	3.36	1.43	9.6	2.28	1.14	7.70
	C*(8,L)C*B12	FC/MC/PC/UC24B	17.6	3.36	1.43	9.6	2.28	1.14	7.70
	(C*9C/T*9V)*B12	FC/MC/PC/UC24B	17.6	3.36	1.43	9.6	2.28	1.14	7.70
	C*(8,L)C*A12	FC/MC/PC/UC30A	17.6	3.36	1.43	9.6	2.28	1.14	7.70
	C*(8,L)C*B12	FC/MC/PC/UC30B	17.6	3.36	1.43	9.6	2.28	1.14	7.70
(C*9C/T*9V)*B12	FC/MC/PC/UC30B	17.6	3.36	1.43	9.6	2.28	1.14	7.70	
C*(8,L)C*A12	HC30	17.6	3.36	1.43	9.6	2.28	1.14	7.70	
THRD24S41S1	T*(8,L)X*A12	FC/MC/PC/UC24A	23.0	3.74	1.66	13.4	2.62	1.32	8.20
	T*(8,L)X*B12	FC/MC/PC/UC24B	23.0	3.74	1.66	13.4	2.62	1.32	8.20
	T*9X*B12	FC/MC/PC/UC24B	23.0	3.74	1.66	13.4	2.62	1.32	8.20
	T*(8,L)X*A12	FC/MC/PC/UC30A	23.0	3.74	1.66	13.4	2.62	1.32	8.20
	T*(8,L)X*B12	FC/MC/PC/UC30B	23.0	3.74	1.66	13.4	2.62	1.32	8.20
	T*9X*B12	FC/MC/PC/UC30B	23.0	3.74	1.66	13.4	2.62	1.32	8.20
	T*(8,L)X*A12	HC30	23.0	3.74	1.66	13.4	2.62	1.32	8.20
	C*(8,L)C*A12	FC/MC/PC/UC24A	23.0	3.74	1.66	13.4	2.62	1.32	8.20
	C*(8,L)C*B12	FC/MC/PC/UC24B	23.0	3.74	1.66	13.4	2.62	1.32	8.20
	(C*9C/T*9V)*B12	FC/MC/PC/UC24B	23.0	3.74	1.66	13.4	2.62	1.32	8.20
	C*(8,L)C*A12	FC/MC/PC/UC30A	23.0	3.74	1.66	13.4	2.62	1.32	8.20
	C*(8,L)C*B12	FC/MC/PC/UC30B	23.0	3.74	1.66	13.4	2.62	1.32	8.20
(C*9C/T*9V)*B12	FC/MC/PC/UC30B	23.0	3.74	1.66	13.4	2.62	1.32	8.20	
C*(8,L)C*A12	HC30	23.0	3.74	1.66	13.4	2.62	1.32	8.20	
THRD30S41S1	T*(8,L)X*B12	FC/MC/PC/UC43B	28.0	3.70	2.02	14.0	2.46	1.56	8.20
	T*9X*B12	FC/MC/PC/UC43B	28.0	3.70	2.02	14.0	2.46	1.56	8.20
	T*(8,L)X*C16	FC/MC/PC/UC43C	28.0	3.70	2.02	14.0	2.46	1.56	8.20
	T*9X*C16	FC/MC/PC/UC43C	28.0	3.70	2.02	14.0	2.46	1.56	8.20
	T*(8,L)X*C16	HC42	28.0	3.70	2.02	14.0	2.46	1.56	8.20
	T*9X*C16	HC42	28.0	3.70	2.02	14.0	2.46	1.56	8.20
	C*(8,L)C*B12	FC/MC/PC/UC43B	28.0	3.70	2.02	14.0	2.46	1.56	8.20
	(C*9C/T*9V)*B12	FC/MC/PC/UC43B	28.0	3.70	2.02	14.0	2.46	1.56	8.20
	C*(8,L)C*C16	FC/MC/PC/UC43C	28.0	3.70	2.02	14.0	2.46	1.56	8.20
	(C*9C/T*9V)*C16	FC/MC/PC/UC43C	28.0	3.70	2.02	14.0	2.46	1.56	8.20
	C*(8,L)C*C16	HC42	28.0	3.70	2.02	14.0	2.46	1.56	8.20
	(C*9C/T*9V)*C16	HC42	28.0	3.70	2.02	14.0	2.46	1.56	8.20

For Notes See Page 9.

HEATING CAPACITY - With High Efficiency Motor Furnaces (Continued)

UNIT MODEL	VARIABLE SPEED FURNACE	COIL ¹ MODEL	ARI HEATING ²						
			47°F			17°F			HSPF
			MBH	COP	KW	MBH	COP	KW	STD
13 SEER HP WITH VARIABLE SPEED FURNACES³									
THRD36S41S1	T*(8,L)X*C16	FC/MC/PC/UC43C	33.0	3.70	2.53	17.9	2.38	2.01	8.00
	T*9X*C16	FC/MC/PC/UC43C	33.0	3.70	2.53	17.9	2.38	2.01	8.00
	T*(8,L)X*C20	FC/MC/PC/UC43C	33.0	3.70	2.53	17.9	2.38	2.01	8.00
	T*9X*C20	FC/MC/PC/UC43C	33.0	3.70	2.53	17.9	2.38	2.01	8.00
	T*(8,L)X*C16	HC42	33.0	3.70	2.53	17.9	2.38	2.01	8.00
	T*9X*C16	HC42	33.0	3.70	2.53	17.9	2.38	2.01	8.00
	T*(8,L)X*C20	HC42	33.0	3.70	2.53	17.9	2.38	2.01	8.00
	T*9X*C20	HC42	33.0	3.70	2.53	17.9	2.38	2.01	8.00
	C*(8,L)C*C16	FC/MC/PC/UC43C	33.0	3.70	2.53	17.9	2.38	2.01	8.00
	(C*9C/T*9V)*C16	FC/MC/PC/UC43C	33.0	3.70	2.53	17.9	2.38	2.01	8.00
	C*(8,L)C*C20	FC/MC/PC/UC43C	33.0	3.70	2.53	17.9	2.38	2.01	8.00
	(C*9C/T*9V)*C20	FC/MC/PC/UC43C	33.0	3.70	2.53	17.9	2.38	2.01	8.00
	C*(8,L)C*C16	HC42	33.0	3.70	2.53	17.9	2.38	2.01	8.00
	(C*9C/T*9V)*C16	HC42	33.0	3.70	2.53	17.9	2.38	2.01	8.00
C*(8,L)C*C20	HC42	33.0	3.70	2.53	17.9	2.38	2.01	8.00	
(C*9C/T*9V)*C20	HC42	33.0	3.70	2.53	17.9	2.38	2.01	8.00	
THRD42S41S1	T*(8,L)X*C16	FC/MC/PC/UC48C	40.0	3.95	2.64	23.4	2.76	2.17	8.75
	T*9X*C16	FC/MC/PC/UC48C	40.0	3.95	2.64	23.4	2.76	2.17	8.75
	T*(8,L)X*C20	FC/MC/PC/UC48C	40.0	3.95	2.64	23.4	2.76	2.17	8.75
	T*9X*C20	FC/MC/PC/UC48C	40.0	3.95	2.64	23.4	2.76	2.17	8.75
	T*9X*D20	FC/MC/PC/UC48D	40.0	3.95	2.64	23.4	2.76	2.17	8.75
	T*(8,L)X*C16	FC/PC/UC60C	40.5	4.00	2.64	23.4	2.76	2.17	8.75
	T*9X*C16	FC/PC/UC60C	40.5	4.00	2.64	23.4	2.76	2.17	8.75
	T*(8,L)X*C20	FC/PC/UC60C	40.5	4.00	2.64	23.4	2.76	2.17	8.75
	T*9X*C20	FC/PC/UC60C	40.5	4.00	2.64	23.4	2.76	2.17	8.75
	T*9X*D20	FC/MC/PC/UC60D	40.5	4.00	2.64	23.4	2.76	2.17	8.75
	T*9X*D20	HC60	40.5	4.00	2.64	23.4	2.76	2.17	8.75
	C*(8,L)C*C16	FC/MC/PC/UC48C	40.0	3.95	2.64	23.4	2.76	2.17	8.75
	(C*9C/T*9V)*C16	FC/MC/PC/UC48C	40.0	3.95	2.64	23.4	2.76	2.17	8.75
	C*(8,L)C*C20	FC/MC/PC/UC48C	40.0	3.95	2.64	23.4	2.76	2.17	8.75
	(C*9C/T*9V)*C20	FC/MC/PC/UC48C	40.0	3.95	2.64	23.4	2.76	2.17	8.75
	(C*9C/T*9V)*D20	FC/MC/PC/UC48D	40.0	3.95	2.64	23.4	2.76	2.17	8.75
	C*(8,L)C*C16	FC/PC/UC60C	40.5	4.00	2.64	23.4	2.76	2.17	8.75
	(C*9C/T*9V)*C16	FC/PC/UC60C	40.5	4.00	2.64	23.4	2.76	2.17	8.75
	C*(8,L)C*C20	FC/PC/UC60C	40.5	4.00	2.64	23.4	2.76	2.17	8.75
	(C*9C/T*9V)*C20	FC/PC/UC60C	40.5	4.00	2.64	23.4	2.76	2.17	8.75
(C*9C/T*9V)*D20	FC/MC/PC/UC60D	40.5	4.00	2.64	23.4	2.76	2.17	8.75	
(C*9C/T*9V)*D20	HC60	40.5	4.00	2.64	23.4	2.76	2.17	8.75	
THRD48S41S1	T*(8,L)X*C20	FC/MC62D	46.0	4.00	3.10	27.0	2.78	1.82	8.20
	T*9X*C20	FC/MC62D	46.0	4.00	3.10	27.0	2.78	1.82	8.20
	T*9X*D20	FC/MC62D	46.0	4.00	3.10	27.0	2.78	1.82	8.20
	C*(8,L)C*C20	FC/MC62D	46.0	4.00	3.10	27.0	2.78	1.82	8.20
	(C*9C/T*9V)*C20	FC/MC62D	46.0	4.00	3.10	27.0	2.78	1.82	8.20
	(C*9C/T*9V)*D20	FC/MC62D	46.0	4.00	3.10	27.0	2.78	1.82	8.20
THRD60S41S1	T*(8,L)X*C20	FC/MC62D	55.5	3.42	4.11	34.6	2.44	3.51	8.00
	T*9X*C20	FC/MC62D	56.0	3.36	4.24	35.0	2.40	3.63	8.00
	T*9X*D20	FC/MC62D	56.0	3.46	4.10	35.0	2.42	3.59	8.00
	C*(8,L)C*C20	FC/MC62D	55.5	3.42	4.11	34.6	2.44	3.51	8.00
	(C*9C/T*9V)*C20	FC/MC62D	56.0	3.36	4.24	35.0	2.40	3.63	8.00
	(C*9C/T*9V)*D20	FC/MC62D	56.0	3.46	4.10	35.0	2.42	3.59	8.00

1. Rated CFM same as for cooling.

2. Heating MBH based on ARI standards of 70° DB entering indoor air, 72% RH outdoor air with 25 feet of interconnecting piping and no supplemental electric heat operation.

3. Variable speed furnaces have B.O.D (Blower on Delay) standard.

CP equals MBH output divided by (total KW input x 3.412).

HSPF (Heating Seasonal Performance Factor) is the total heating output during a normal annual usage period for heating divided by the total electric power input during the same period.

— = Not Applicable.

ACCESSORIES

Refer to Price Manual for specific model numbers.

Start Assist Kit (2SA067*) - May be required on 42, 48, 60 models. Models 18, 24, 30, 36 have been factory installed.

Blower Time Delay - Available to increase efficiency when installed. Installs on indoor section and maintains blower for approximately one minute after cooling thermostat has been satisfied.

Hard Start Kits - Provides required starting torque for use with Thermal Expansion Valve Kit.

Low Temperature Cutout (2LT06700224) - Prevents heat pump operation below -10°F ambient temperature.

Compressor Blanket - Designed to further reduce the normal operating sound.

Add-on Fossil Fuel Control - Interface controls for use with gas, oil furnaces and the heat pump system are available.

Thermal Expansion Valve Kit - 1TVM900 Series TXV kit used to improve system performance.

Outdoor Thermostat (2TD06700124) - Provides additional staging of supplemental electric heat.

Thermostats - Compatible thermostat controls are available through accessory sourcing. For optimum performance and installation, refer to the UPGNET "Low Voltage Wiring Diagram" document to select and apply controls.

SOUND POWER RATINGS

UNIT MODEL	(dBA)*	
	Cooling	Heating
018	72.8	75.9
024	74.8	75.2
030	76.8	80.4
036	76.5	78.2
042	72.7	75.2
048	76.7	78.1
060	77.2	78.9

* Rated in accordance with ARI 270-95 Standards.

TYPICAL INSTALLATION

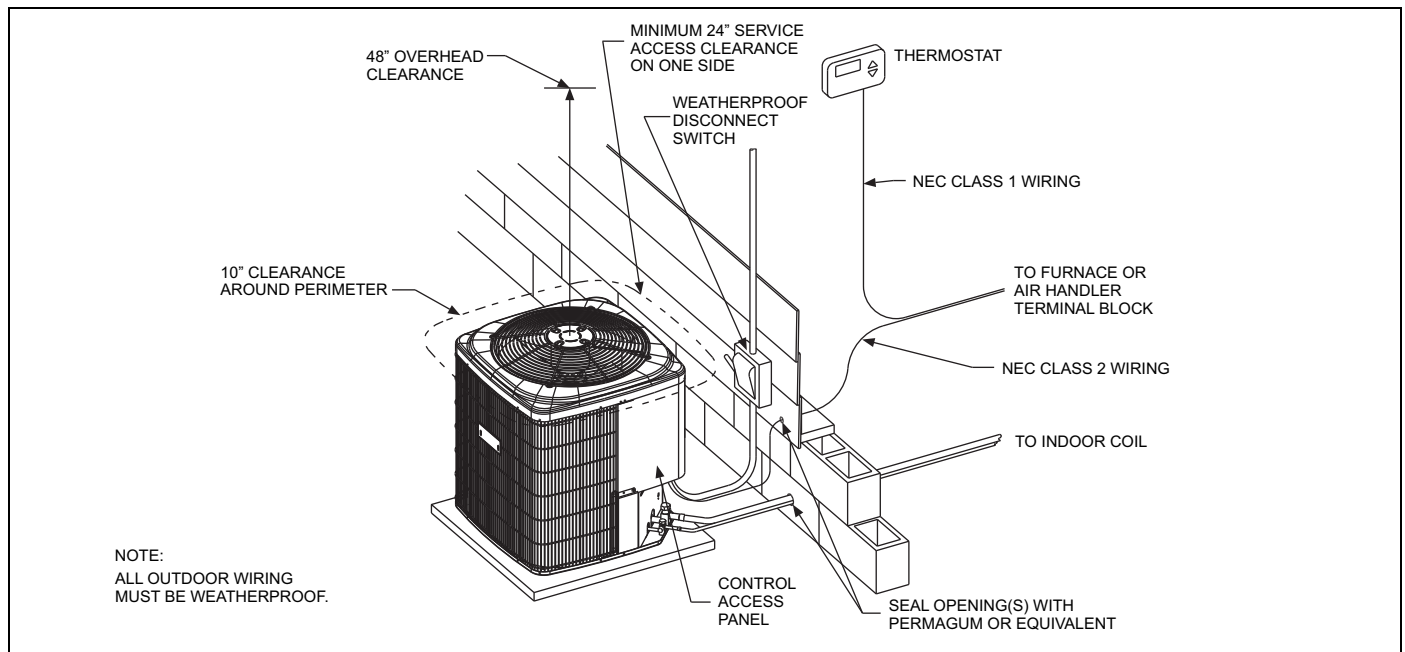

TYPICAL FIELD WIRING

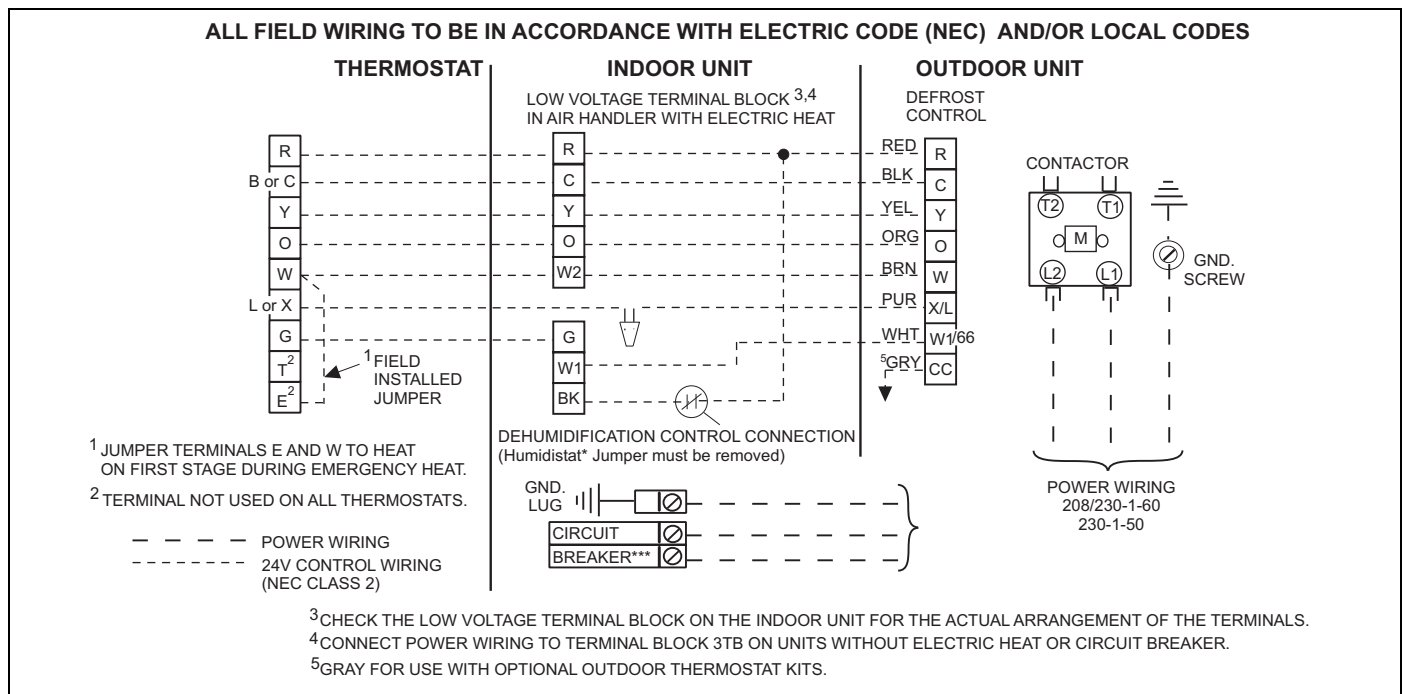

COOLING PERFORMANCE DATA																
CONDENSING UNIT MODEL NO.		THRD18S41S1														
INDOOR COIL MODEL NO.		F6FP18														
CONDENSING ENTERING AIR TEMPERATURE	IDCFM	450					600					750				
	ID DB (°F)	80	80	75	80	80	80	80	75	80	80	80	80	75	80	80
	ID WB (°F)	57	62	62	67	72	57	62	62	67	72	57	62	62	67	72
65	T.C.	18.1	19.9	20.3	22.0	23.3	19.9	21.2	21.3	22.8	23.9	21.8	22.5	22.4	23.5	24.6
	S.C.	18.0	16.0	14.2	14.1	12.1	19.9	18.4	15.6	15.2	12.7	21.7	20.7	17.0	16.3	13.3
	KW	1.3	1.3	1.3	1.3	1.3	1.4	1.4	1.4	1.4	1.4	1.4	1.5	1.5	1.5	1.5
75	T.C.	17.2	18.6	18.9	20.7	22.0	18.9	19.8	19.8	21.4	22.7	20.5	20.9	20.8	22.1	23.3
	S.C.	17.1	15.4	13.5	13.5	11.5	18.8	17.6	14.9	14.6	12.1	20.5	19.7	16.4	15.8	12.7
	KW	1.3	1.4	1.4	1.4	1.4	1.4	1.5	1.5	1.5	1.5	1.5	1.5	1.5	1.6	1.6
85	T.C.	16.3	17.4	17.5	19.4	20.8	17.8	18.3	18.3	20.1	21.4	19.3	19.3	19.1	20.8	22.1
	S.C.	16.2	14.9	12.8	12.8	10.8	17.8	16.8	14.3	14.1	11.5	19.3	18.7	15.8	15.4	12.1
	KW	1.4	1.5	1.5	1.5	1.5	1.5	1.5	1.5	1.6	1.6	1.6	1.6	1.6	1.7	1.7
95	T.C.	15.4	16.1	16.1	18.1	19.6	16.7	16.9	16.8	18.7	20.2	18.1	17.7	17.5	19.4	20.8
	S.C.	15.3	14.3	12.1	12.2	10.1	16.7	16.0	13.6	13.6	10.8	18.1	17.7	15.2	14.9	11.5
	KW	1.5	1.5	1.5	1.6	1.6	1.6	1.6	1.6	1.7	1.7	1.7	1.7	1.7	1.8	1.8
105	T.C.	14.1	14.1	13.7	16.5	18.2	15.4	14.8	14.7	17.0	18.7	16.7	15.6	15.8	17.5	19.2
	S.C.	14.1	12.9	11.0	11.6	9.5	15.3	14.2	12.6	12.9	10.2	16.6	15.5	14.2	14.3	10.9
	KW	1.6	1.6	1.6	1.7	1.7	1.7	1.7	1.7	1.8	1.8	1.8	1.8	1.8	1.8	1.9
115	T.C.	12.8	12.1	11.2	15.0	16.9	14.0	12.8	12.6	15.3	17.2	15.2	13.5	14.1	15.6	17.6
	S.C.	12.8	11.5	9.9	10.9	8.8	14.0	12.5	11.6	12.3	9.6	15.2	13.4	13.3	13.6	10.3
	KW	1.7	1.7	1.7	1.8	1.8	1.8	1.8	1.8	1.8	1.9	1.9	1.9	1.9	1.9	2.0
125	T.C.	11.5	10.1	8.8	13.4	15.5	12.7	10.7	10.6	13.6	15.7	13.8	11.4	12.3	13.7	15.9
	S.C.	11.5	10.1	8.8	10.3	8.2	12.6	10.7	10.5	11.6	9.0	13.7	11.3	12.3	12.9	9.7
	KW	1.7	1.8	1.7	1.9	1.9	1.9	1.9	1.8	1.9	2.0	2.0	2.0	1.9	2.0	2.1

NOTE: ALL CAPACITIES INCLUDE INDOOR FAN HEAT AT 1250 BTUH/1000 CFM.

Multipliers for determining the performance with other indoor sections.

NOTE: For dry bulb temperatures different than those listed (between 73-87 F), sensible capacity increases by 1060 BTUH per 1000 CFM per degree above the listed temperature and decreases by 1060 BTUH per 1000 CFM per degree below the listed temperature.

Air Handler	Coil	T.C.	S.C.	KW
AHX18	—	1.02	1.03	0.98
AHX24	—	1.02	1.02	0.98
AV*24	—	1.00	1.00	1.00
F6FP24	—	1.00	1.00	1.00
MV12B	FC/MC18B	1.00	1.00	1.00
MV12B	FC/MC24B	1.00	1.00	1.00
MV12B	FC/MC30B	1.00	1.00	1.00

Furnace	Coil	T.C.	S.C.	KW
T*(8,L)X*A12	FC/MC/PC/UC24A	1.00	1.00	1.00
T*(8,L)X*B12	FC/MC/PC/UC24B	1.00	1.00	1.00
T*9X*B12	FC/MC/PC/UC24B	1.00	1.00	1.00
T*(8,L)X*A12	FC/MC/PC/UC30A	1.00	1.00	1.00
T*(8,L)X*B12	FC/MC/PC/UC30B	1.00	1.00	1.00
T*9X*B12	FC/MC/PC/UC30B	1.00	1.00	1.00
T*(8,L)X*A12	HC30	1.00	1.00	1.00
C*(8,L)C*A12	FC/MC/PC/UC24A	1.00	1.00	1.00
C*(8,L)C*B12	FC/MC/PC/UC24B	1.00	1.00	1.00
(C*9C/T*9V)*B12	FC/MC/PC/UC24B	1.00	1.00	1.00
C*(8,L)C*A12	FC/MC/PC/UC30A	1.00	1.00	1.00
C*(8,L)C*B12	FC/MC/PC/UC30B	1.00	1.00	1.00
(C*9C/T*9V)*B12	FC/MC/PC/UC30B	1.00	1.00	1.00
C*(8,L)C*A12	HC30	1.00	1.00	1.00

COOLING PERFORMANCE DATA																
CONDENSING UNIT MODEL NO.		THRD24S41S1														
INDOOR COIL MODEL NO.		F6FP24														
CONDENSING ENTERING AIR TEMPERATURE	IDCFM	600					800					1000				
	ID DB (°F)	80	80	75	80	80	80	80	75	80	80	80	80	75	80	80
	ID WB (°F)	57	62	62	67	72	57	62	62	67	72	57	62	62	67	72
65	T.C.	24.4	26.0	26.9	29.5	30.7	26.4	26.3	28.0	30.4	31.4	28.4	26.5	29.0	31.4	32.0
	S.C.	23.8	21.5	18.7	18.8	15.3	25.7	23.7	20.9	20.2	15.9	27.7	25.9	23.0	21.7	16.4
	KW	1.6	1.6	1.7	1.7	1.7	1.7	1.7	1.8	1.8	1.8	1.8	1.8	1.8	1.9	1.9
75	T.C.	22.6	24.0	24.2	27.3	28.9	24.7	24.7	25.3	28.1	29.7	26.8	25.4	26.5	28.8	30.4
	S.C.	22.1	20.6	17.5	17.8	14.6	24.1	22.7	19.8	19.5	15.3	26.1	24.8	22.0	21.1	16.0
	KW	1.7	1.7	1.7	1.8	1.8	1.8	1.8	1.8	1.9	1.9	1.9	1.9	1.9	2.0	2.0
85	T.C.	20.9	21.9	21.4	25.2	27.1	23.0	23.1	22.7	25.8	28.0	25.1	24.3	24.0	26.3	28.8
	S.C.	20.4	19.8	16.4	16.9	13.8	22.4	21.8	18.7	18.7	14.7	24.5	23.7	21.1	20.5	15.6
	KW	1.8	1.8	1.8	1.9	2.0	1.9	1.9	1.9	2.0	2.1	2.1	2.1	2.0	2.1	2.2
95	T.C.	19.1	19.9	18.7	23.1	25.3	21.3	21.6	20.1	23.4	26.3	23.5	23.2	21.5	23.8	27.3
	S.C.	18.6	18.9	15.2	16.0	13.1	20.8	20.8	17.6	18.0	14.1	23.0	22.7	20.1	19.9	15.2
	KW	1.9	1.9	1.9	2.0	2.1	2.0	2.0	2.0	2.1	2.2	2.2	2.2	2.1	2.2	2.3
105	T.C.	17.4	17.8	16.4	20.1	23.3	19.3	19.8	17.8	20.8	24.1	21.3	21.8	19.1	21.5	24.9
	S.C.	16.9	17.1	14.2	14.9	12.2	18.9	19.2	16.2	17.0	13.4	20.8	21.2	18.2	19.1	14.6
	KW	2.0	2.0	1.9	2.1	2.2	2.1	2.1	2.1	2.2	2.3	2.3	2.3	2.2	2.3	2.4
115	T.C.	15.6	15.6	14.2	17.2	21.3	17.4	18.0	15.4	18.2	22.0	19.1	20.3	16.7	19.1	22.6
	S.C.	15.2	15.2	13.3	13.8	11.2	17.0	17.5	14.8	16.0	12.6	18.7	19.8	16.3	18.3	14.0
	KW	2.1	2.1	2.0	2.1	2.3	2.2	2.3	2.1	2.3	2.4	2.4	2.4	2.3	2.4	2.5
125	T.C.	13.9	13.5	11.9	14.2	19.4	15.4	16.2	13.1	15.5	19.8	16.9	18.9	14.4	16.8	20.3
	S.C.	13.5	13.4	11.9	12.6	10.3	15.0	15.9	13.1	15.0	11.9	16.5	18.4	14.4	16.8	13.5
	KW	2.2	2.1	2.1	2.2	2.4	2.3	2.4	2.2	2.3	2.5	2.5	2.6	2.4	2.5	2.7

NOTE: ALL CAPACITIES INCLUDE INDOOR FAN HEAT AT 1250 BTUH/1000 CFM.

Multipliers for determining the performance with other indoor sections.

NOTE: For dry bulb temperatures different than those listed (between 73-87 F), sensible capacity increases by 1060 BTUH per 1000 CFM per degree above the listed temperature and decreases by 1060 BTUH per 1000 CFM per degree below the listed temperature.

Air Handler	Coil	T.C.	S.C.	KW
AHX24	–	1.02	1.02	0.99
AHX30	–	1.05	1.05	1.00
AV*24	–	1.00	1.00	1.00
MV12B	FC/MC24B	1.00	1.00	1.00
MV12B	FC/MC30B	1.00	1.00	1.00

Furnace	Coil	T.C.	S.C.	KW
T*(8,L)X*A12	FC/MC/PC/UC24A	1.00	1.00	1.00
T*(8,L)X*B12	FC/MC/PC/UC24B	1.00	1.00	1.00
T*9X*B12	FC/MC/PC/UC24B	1.00	1.00	1.00
T*(8,L)X*A12	FC/MC/PC/UC30A	1.00	1.00	1.00
T*(8,L)X*B12	FC/MC/PC/UC30B	1.00	1.00	1.00
T*9X*B12	FC/MC/PC/UC30B	1.00	1.00	1.00
T*(8,L)X*A12	HC30	1.00	1.00	1.00
C*(8,L)C*A12	FC/MC/PC/UC24A	1.00	1.00	1.00
C*(8,L)C*B12	FC/MC/PC/UC24B	1.00	1.00	1.00
(C*9C/T*9V)*B12	FC/MC/PC/UC24B	1.00	1.00	1.00
C*(8,L)C*A12	FC/MC/PC/UC30A	1.00	1.00	1.00
C*(8,L)C*B12	FC/MC/PC/UC30B	1.00	1.00	1.00
(C*9C/T*9V)*B12	FC/MC/PC/UC30B	1.00	1.00	1.00
C*(8,L)C*A12	HC30	1.00	1.00	1.00

COOLING PERFORMANCE DATA																
CONDENSING UNIT MODEL NO.		THRD30S41S1														
INDOOR COIL MODEL NO.		F6FP30														
CONDENSING ENTERING AIR TEMPERATURE	IDCFM	800					1000					1200				
	ID DB (°F)	80	80	75	80	80	80	80	75	80	80	80	80	75	80	80
	ID WB (°F)	57	62	62	67	72	57	62	62	67	72	57	62	62	67	72
65	T.C.	29.7	32.9	32.9	35.3	38.2	31.8	33.6	33.9	36.4	39.1	33.9	34.4	34.8	37.5	40.0
	S.C.	29.1	26.1	22.6	22.0	18.5	31.2	29.0	24.5	23.9	19.4	33.3	31.8	26.4	25.8	20.3
	KW	2.0	2.0	2.0	2.1	2.1	2.1	2.1	2.1	2.2	2.2	2.2	2.2	2.2	2.3	2.3
75	T.C.	28.1	30.6	30.6	33.2	36.0	30.1	31.5	31.5	34.2	36.9	32.1	32.3	32.5	35.2	37.7
	S.C.	27.5	25.1	21.5	21.2	17.6	29.5	27.8	23.4	23.1	18.6	31.5	30.4	25.4	25.0	19.5
	KW	2.1	2.1	2.1	2.2	2.3	2.2	2.3	2.3	2.3	2.4	2.4	2.4	2.4	2.4	2.5
85	T.C.	26.4	28.3	28.2	31.1	33.9	28.4	29.3	29.2	32.1	34.6	30.4	30.3	30.2	33.0	35.4
	S.C.	25.9	24.1	20.4	20.3	16.8	27.8	26.6	22.4	22.2	17.7	29.8	29.0	24.4	24.2	18.6
	KW	2.2	2.3	2.3	2.4	2.4	2.4	2.4	2.4	2.5	2.5	2.5	2.5	2.5	2.6	2.6
95	T.C.	24.8	26.1	25.9	29.1	31.8	26.7	27.1	26.9	29.9	32.4	28.6	28.2	27.9	30.7	33.0
	S.C.	24.3	23.1	19.3	19.4	15.9	26.2	25.4	21.4	21.4	16.8	28.0	27.6	23.5	23.4	17.8
	KW	2.4	2.4	2.4	2.5	2.6	2.5	2.5	2.5	2.6	2.7	2.7	2.6	2.6	2.7	2.8
105	T.C.	23.1	23.6	23.5	26.8	29.4	24.8	25.0	24.4	27.5	30.0	26.6	26.4	25.3	28.2	30.6
	S.C.	22.6	21.9	18.3	18.5	14.9	24.4	23.9	20.4	20.5	15.9	26.1	25.9	22.4	22.4	16.9
	KW	2.5	2.5	2.5	2.7	2.8	2.7	2.7	2.7	2.8	2.9	2.8	2.8	2.8	2.9	3.0
115	T.C.	21.4	21.1	21.2	24.6	27.1	23.0	22.9	21.9	25.1	27.6	24.6	24.6	22.7	25.7	28.2
	S.C.	21.0	20.7	17.3	17.6	13.9	22.5	22.4	19.3	19.5	14.9	24.1	24.1	21.4	21.4	16.0
	KW	2.7	2.7	2.7	2.8	2.9	2.8	2.8	2.8	2.9	3.0	3.0	3.0	2.9	3.0	3.1
125	T.C.	19.7	18.7	18.8	22.3	24.8	21.2	20.7	19.4	22.8	25.3	22.6	22.8	20.1	23.2	25.8
	S.C.	19.3	18.7	16.2	16.7	12.9	20.7	20.7	18.3	18.5	14.0	22.1	22.3	20.1	20.4	15.1
	KW	2.8	2.8	2.8	3.0	3.1	3.0	3.0	2.9	3.1	3.2	3.2	3.2	3.1	3.2	3.3

NOTE: ALL CAPACITIES INCLUDE INDOOR FAN HEAT AT 1250 BTUH/1000 CFM.

Multipliers for determining the performance with other indoor sections.

NOTE: For dry bulb temperatures different than those listed (between 73-87 F), sensible capacity increases by 1060 BTUH per 1000 CFM per degree above the listed temperature and decreases by 1060 BTUH per 1000 CFM per degree below the listed temperature.

Air Handler	Coil	T.C.	S.C.	KW
AHX36	-	1.03	1.06	0.98
AV*36	-	1.00	1.00	1.00
F6FP36	-	1.00	1.00	1.00
MV16C	FC/MC35C	1.00	1.00	1.00
MV12B	FC/MC43B	1.00	1.00	1.00
MV16C	FC/MC43C	1.00	1.00	1.00

Furnace	Coil	T.C.	S.C.	KW
T*(8,L)X*B12	FC/MC/PC/UC43B	1.00	1.00	1.00
T*9X*B12	FC/MC/PC/UC43B	1.00	1.00	1.00
T*(8,L)X*C16	FC/MC/PC/UC43C	1.00	1.00	1.00
T*9X*C16	FC/MC/PC/UC43C	1.00	1.00	1.00
T*(8,L)X*C16	HC42	1.00	1.00	1.00
T*9X*C16	HC42	1.00	1.00	1.00
C*(8,L)C*B12	FC/MC/PC/UC43B	1.00	1.00	1.00
(C*9C/T*9V)*B12	FC/MC/PC/UC43B	1.00	1.00	1.00
C*(8,L)C*C16	FC/MC/PC/UC43C	1.00	1.00	1.00
(C*9C/T*9V)*C16	FC/MC/PC/UC43C	1.00	1.00	1.00
C*(8,L)C*C16	HC42	1.00	1.00	1.00
(C*9C/T*9V)*C16	HC42	1.00	1.00	1.00

COOLING PERFORMANCE DATA																
CONDENSING UNIT MODEL NO.		THRD36S41S1														
INDOOR COIL MODEL NO.		F6FP36														
CONDENSING ENTERING AIR TEMPERATURE	IDCFM	1000					1200					1400				
	ID DB (°F)	80	80	75	80	80	80	80	75	80	80	80	80	75	80	80
	ID WB (°F)	57	62	62	67	72	57	62	62	67	72	57	62	62	67	72
65	T.C.	35.0	37.8	37.8	41.8	46.1	37.3	39.1	39.1	43.1	47.3	39.5	40.5	40.5	44.4	48.5
	S.C.	34.7	31.0	26.5	26.4	22.0	36.9	34.3	28.6	28.4	23.3	39.1	37.6	30.6	30.4	24.5
	KW	2.4	2.5	2.5	2.5	2.6	2.5	2.6	2.6	2.6	2.6	2.6	2.6	2.6	2.7	2.7
75	T.C.	32.9	34.9	34.9	38.9	43.4	35.0	36.1	36.1	40.2	44.4	37.1	37.2	37.3	41.4	45.5
	S.C.	32.6	29.7	25.2	25.2	20.9	34.6	32.4	27.2	27.2	22.1	36.7	35.2	29.2	29.2	23.3
	KW	2.6	2.7	2.7	2.7	2.7	2.7	2.7	2.7	2.8	2.8	2.8	2.8	2.8	2.8	2.9
85	T.C.	30.8	32.0	32.0	36.0	40.7	32.7	33.0	33.1	37.2	41.6	34.6	34.0	34.1	38.4	42.5
	S.C.	30.4	28.4	23.9	24.0	19.7	32.3	30.6	25.9	26.0	20.9	34.2	32.8	27.9	28.0	22.1
	KW	2.7	2.8	2.8	2.8	2.9	2.8	2.9	2.9	2.9	3.0	3.0	2.9	2.9	3.0	3.1
95	T.C.	28.6	29.1	29.2	33.1	38.0	30.4	30.0	30.0	34.3	38.8	32.1	30.8	30.9	35.4	39.5
	S.C.	28.3	27.1	22.6	22.8	18.6	30.1	28.8	24.6	24.8	19.7	31.8	30.4	26.5	26.8	20.8
	KW	2.9	2.9	2.9	3.0	3.1	3.0	3.0	3.0	3.1	3.2	3.1	3.1	3.1	3.2	3.3
105	T.C.	26.1	26.4	25.7	29.7	34.3	27.8	27.6	26.4	30.6	35.3	29.5	28.8	27.2	31.6	36.3
	S.C.	25.8	25.2	21.1	21.4	17.3	27.5	26.9	23.0	23.4	18.4	29.2	28.5	24.8	25.4	19.6
	KW	3.1	3.1	3.0	3.1	3.3	3.2	3.2	3.1	3.3	3.4	3.3	3.3	3.2	3.4	3.5
115	T.C.	23.6	23.6	22.2	26.2	30.6	25.2	25.2	22.8	27.0	31.8	26.9	26.9	23.4	27.8	33.1
	S.C.	23.3	23.3	19.6	20.1	15.9	25.0	25.0	21.4	22.0	17.2	26.6	26.6	23.2	23.9	18.4
	KW	3.2	3.2	3.2	3.3	3.5	3.4	3.4	3.3	3.4	3.6	3.5	3.5	3.4	3.5	3.7
125	T.C.	21.1	20.8	18.7	22.7	26.9	22.6	22.8	19.2	23.3	28.4	24.2	24.9	19.7	24.0	29.8
	S.C.	20.8	20.8	18.1	18.7	14.6	22.4	22.8	19.2	20.6	15.9	24.0	24.6	19.7	22.5	17.2
	KW	3.4	3.4	3.3	3.5	3.7	3.5	3.5	3.4	3.6	3.8	3.7	3.7	3.5	3.7	3.9

NOTE: ALL CAPACITIES INCLUDE INDOOR FAN HEAT AT 1250 BTUH/1000 CFM.

Multipliers for determining the performance with other indoor sections.

NOTE: For dry bulb temperatures different than those listed (between 73-87 F), sensible capacity increases by 1060 BTUH per 1000 CFM per degree above the listed temperature and decreases by 1060 BTUH per 1000 CFM per degree below the listed temperature.

Air Handler	Coil	T.C.	S.C.	KW
AHX36	–	1.03	1.06	0.98
AV*36	–	1.02	1.00	1.00
MV16C	FC/MC35C	1.00	1.00	1.00
MV16C	FC/MC43C	1.02	1.00	1.00

Furnace	Coil	T.C.	S.C.	KW
T*(8,L)X*C16	FC/MC/PC/UC43C	1.00	1.00	1.00
T*9X*C16	FC/MC/PC/UC43C	1.00	1.00	1.00
T*(8,L)X*C20	FC/MC/PC/UC43C	1.00	1.00	1.00
T*9X*C20	FC/MC/PC/UC43C	1.00	1.00	1.00
T*(8,L)X*C16	HC42	1.00	1.00	1.00
T*9X*C16	HC42	1.00	1.00	1.00
T*(8,L)X*C20	HC42	1.00	1.00	1.00
T*9X*C20	HC42	1.00	1.00	1.00
C*(8,L)C*C16	FC/MC/PC/UC43C	1.00	1.00	1.00
(C*9C/T*9V)*C16	FC/MC/PC/UC43C	1.00	1.00	1.00
C*(8,L)C*C20	FC/MC/PC/UC43C	1.00	1.00	1.00
(C*9C/T*9V)*C20	FC/MC/PC/UC43C	1.00	1.00	1.00
C*(8,L)C*C16	HC42	1.00	1.00	1.00
(C*9C/T*9V)*C16	HC42	1.00	1.00	1.00
C*(8,L)C*C20	HC42	1.00	1.00	1.00
(C*9C/T*9V)*C20	HC42	1.00	1.00	1.00

COOLING PERFORMANCE DATA																
CONDENSING UNIT MODEL NO.		THRD42S41S1														
INDOOR COIL MODEL NO.		F6FP42														
CONDENSING ENTERING AIR TEMPERATURE	IDCFM	1200					1400					1600				
	ID DB (°F)	80	80	75	80	80	80	80	75	80	80	80	80	75	80	80
	ID WB (°F)	57	62	62	67	72	57	62	62	67	72	57	62	62	67	72
65	T.C.	43.1	45.7	46.2	51.4	56.6	45.5	46.9	47.2	52.7	57.8	47.9	48.0	48.2	54.0	59.1
	S.C.	43.1	40.8	34.9	34.9	28.6	45.5	44.6	37.1	37.1	30.0	47.9	48.0	39.3	39.3	31.3
	KW	2.5	2.5	2.5	2.6	2.6	2.6	2.6	2.5	2.6	2.7	2.7	2.6	2.6	2.7	2.8
75	T.C.	40.3	42.3	42.3	47.4	52.5	42.5	43.6	43.6	48.6	53.9	44.7	44.8	44.8	49.8	55.2
	S.C.	40.3	39.3	33.1	33.2	26.9	42.5	42.4	35.4	35.4	28.4	44.7	44.8	37.8	37.6	29.8
	KW	2.7	2.6	2.6	2.7	2.8	2.8	2.7	2.7	2.8	2.9	2.8	2.8	2.8	2.9	3.0
85	T.C.	37.6	38.9	38.4	43.5	48.5	39.6	40.3	40.0	44.5	49.9	41.6	41.7	41.5	45.6	51.4
	S.C.	37.6	37.7	31.2	31.5	25.3	39.6	40.3	33.7	33.7	26.8	41.6	41.7	36.2	35.9	28.2
	KW	2.9	2.8	2.8	2.9	3.0	2.9	2.9	2.9	3.0	3.1	3.0	3.0	3.0	3.1	3.2
95	T.C.	34.8	35.4	34.5	39.6	44.5	36.6	37.0	36.3	40.5	46.0	38.4	38.5	38.1	41.4	47.5
	S.C.	34.8	35.4	29.4	29.9	23.7	36.6	37.0	32.1	32.0	25.2	38.4	38.5	34.7	34.2	26.6
	KW	3.0	3.0	3.0	3.0	3.2	3.1	3.1	3.1	3.1	3.3	3.2	3.2	3.2	3.3	3.3
105	T.C.	29.7	30.7	28.6	33.3	40.4	32.4	32.9	30.2	35.1	40.4	35.1	35.2	31.7	36.9	40.4
	S.C.	29.7	30.7	26.6	27.3	22.1	32.4	32.9	28.5	29.9	23.1	35.1	35.2	30.5	32.4	24.1
	KW	3.1	3.1	3.1	3.2	3.4	3.2	3.2	3.2	3.3	3.4	3.3	3.3	3.3	3.4	3.5
115	T.C.	24.5	25.9	22.7	27.1	36.3	28.2	28.9	24.0	29.7	34.8	31.8	31.8	25.3	32.4	33.2
	S.C.	24.5	25.9	22.7	24.8	20.5	28.2	28.9	24.0	27.8	21.0	31.8	31.8	25.3	30.7	21.6
	KW	3.3	3.3	3.2	3.3	3.5	3.4	3.4	3.3	3.4	3.6	3.5	3.5	3.4	3.5	3.7
125	T.C.	19.4	21.1	16.8	20.9	32.3	23.9	24.8	17.8	24.4	29.1	28.5	28.5	18.9	27.8	26.0
	S.C.	19.4	21.1	16.8	20.9	18.9	23.9	24.8	17.8	24.4	19.0	28.5	28.5	18.9	27.8	19.1
	KW	3.4	3.5	3.3	3.5	3.7	3.5	3.6	3.4	3.6	3.8	3.7	3.7	3.5	3.7	3.8

NOTE: ALL CAPACITIES INCLUDE INDOOR FAN HEAT AT 1250 BTUH/1000 CFM.

Multipliers for determining the performance with other indoor sections.

NOTE: For dry bulb temperatures different than those listed (between 73-87 F), sensible capacity increases by 1060 BTUH per 1000 CFM per degree above the listed temperature and decreases by 1060 BTUH per 1000 CFM per degree below the listed temperature.

Air Handler	Coil	T.C.	S.C.	KW
AHX42	-	1.01	1.00	0.97
AHX48	-	1.02	1.02	0.98
AV*48	-	1.00	1.00	1.00
AV*60	-	1.00	1.00	1.00
F6FP48	-	1.00	1.00	1.00
MV16C	FC/MC48C	1.00	1.00	1.00
MV20D	FC/MC48D	1.00	1.00	1.00
MV16C	FC/MC60C	1.00	1.00	1.00
MV20D	FC/MC60D	1.00	1.00	1.00

Furnace	Coil	T.C.	S.C.	KW
T*(8,L)X*C16	FC/MC/PC/UC48C	1.00	1.00	1.00
T*9X*C16	FC/MC/PC/UC48C	1.00	1.00	1.00
T*(8,L)X*C20	FC/MC/PC/UC48C	1.00	1.00	1.00
T*9X*C20	FC/MC/PC/UC48C	1.00	1.00	1.00
T*9X*D20	FC/MC/PC/UC48D	1.00	1.00	1.00
T*(8,L)X*C16	FC/PC/UC60C	1.00	1.00	1.00
T*9X*C16	FC/PC/UC60C	1.00	1.00	1.00
T*(8,L)X*C20	FC/PC/UC60C	1.00	1.00	1.00
T*9X*C20	FC/PC/UC60C	1.00	1.00	1.00
T*9X*D20	FC/MC/PC/UC60D	1.00	1.00	1.00
T*9X*D20	HC60	1.00	1.00	1.00
C*(8,L)C*C16	FC/MC/PC/UC48C	1.00	1.00	1.00
(C*9C/T*9V)*C16	FC/MC/PC/UC48C	1.00	1.00	1.00
C*(8,L)C*C20	FC/MC/PC/UC48C	1.00	1.00	1.00
(C*9C/T*9V)*C20	FC/MC/PC/UC48C	1.00	1.00	1.00
(C*9C/T*9V)*D20	FC/MC/PC/UC48D	1.00	1.00	1.00
C*(8,L)C*C16	FC/PC/UC60C	1.00	1.00	1.00
(C*9C/T*9V)*C16	FC/PC/UC60C	1.00	1.00	1.00
C*(8,L)C*C20	FC/PC/UC60C	1.00	1.00	1.00
(C*9C/T*9V)*C20	FC/PC/UC60C	1.00	1.00	1.00
(C*9C/T*9V)*D20	FC/MC/PC/UC60D	1.00	1.00	1.00
(C*9C/T*9V)*D20	HC60	1.00	1.00	1.00

COOLING PERFORMANCE DATA																
CONDENSING UNIT MODEL NO.		THRD48S41S1														
INDOOR COIL MODEL NO.		F6FP48														
CONDENSING ENTERING AIR TEMPERATURE	IDCFM	1400					1600					1800				
	ID DB (°F)	80	80	75	80	80	80	80	75	80	80	80	80	75	80	80
	ID WB (°F)	57	62	62	67	72	57	62	62	67	72	57	62	62	67	72
65	T.C.	48.9	52.7	52.5	58.0	62.8	50.9	53.6	53.6	59.0	64.0	52.9	54.6	54.8	60.0	65.2
	S.C.	48.9	46.4	39.4	39.3	31.8	50.9	49.7	41.6	41.3	32.9	52.9	53.1	43.8	43.4	33.9
	KW	3.1	3.2	3.2	3.3	3.5	3.2	3.2	3.3	3.4	3.6	3.2	3.3	3.3	3.6	3.7
75	T.C.	46.2	48.8	48.8	54.3	59.2	48.2	49.8	49.8	55.2	60.0	50.3	50.8	50.8	56.2	60.8
	S.C.	46.2	44.5	37.7	37.7	30.4	48.2	47.5	39.8	39.7	31.5	50.3	50.5	42.0	41.8	32.6
	KW	3.3	3.4	3.4	3.5	3.7	3.4	3.5	3.5	3.7	3.8	3.5	3.5	3.6	3.8	3.9
85	T.C.	43.4	44.9	45.1	50.5	55.6	45.5	45.9	45.9	51.5	56.0	47.6	46.9	46.8	52.4	56.5
	S.C.	43.4	42.7	35.9	36.0	28.9	45.5	45.3	38.0	38.1	30.1	47.6	46.9	40.2	40.2	31.2
	KW	3.5	3.6	3.6	3.7	3.9	3.6	3.7	3.7	3.9	4.0	3.8	3.8	3.8	4.0	4.1
95	T.C.	40.6	40.9	41.3	46.7	52.0	42.8	42.0	42.1	47.7	52.1	44.9	43.0	42.8	48.6	52.1
	S.C.	40.6	40.8	34.1	34.4	27.5	42.8	42.0	36.2	36.5	28.7	44.9	43.0	38.3	38.6	29.8
	KW	3.7	3.8	3.7	4.0	4.1	3.9	3.9	3.9	4.1	4.2	4.0	4.0	4.0	4.2	4.3
105	T.C.	37.2	37.4	36.7	43.0	47.9	39.3	38.9	37.4	43.7	48.2	41.4	40.4	38.1	44.4	48.4
	S.C.	37.2	37.4	32.0	32.8	25.9	39.3	38.9	34.1	34.9	27.0	41.4	40.4	36.3	36.9	28.1
	KW	3.9	4.0	3.9	4.1	4.3	4.1	4.1	4.0	4.3	4.4	4.3	4.2	4.1	4.4	4.5
115	T.C.	33.7	33.8	32.1	39.2	43.9	35.8	35.8	32.8	39.7	44.3	37.8	37.8	33.4	40.2	44.7
	S.C.	33.7	33.8	29.9	31.2	24.4	35.8	35.8	32.1	33.2	25.4	37.8	37.8	33.4	35.2	26.5
	KW	4.1	4.1	4.1	4.3	4.6	4.3	4.3	4.2	4.5	4.7	4.5	4.5	4.3	4.6	4.8
125	T.C.	30.3	30.2	27.5	35.4	39.8	32.3	32.7	28.1	35.7	40.4	34.3	35.2	28.7	35.9	40.9
	S.C.	30.3	30.2	27.5	29.6	22.9	32.3	32.7	28.1	31.5	23.8	34.3	35.2	28.7	33.5	24.8
	KW	4.4	4.3	4.2	4.5	4.8	4.5	4.5	4.4	4.7	4.9	4.7	4.7	4.5	4.8	5.0

NOTE: ALL CAPACITIES INCLUDE INDOOR FAN HEAT AT 1250 BTUH/1000 CFM.

Multipliers for determining the performance with other indoor sections.

NOTE: For dry bulb temperatures different than those listed (between 73-87 F), sensible capacity increases by 1060 BTUH per 1000 CFM per degree above the listed temperature and decreases by 1060 BTUH per 1000 CFM per degree below the listed temperature.

Air Handler	Coil	T.C.	S.C.	KW
MV20D	FC/MC60D	1.00	1.00	1.00
MV20D	FC/MC62D	1.00	1.00	1.00
AHX48	—	0.99	1.00	0.98
AHX60	—	1.00	1.00	0.99
AV*48	—	1.00	1.00	1.00
AV*60	—	1.00	1.00	1.00
F6FP60	—	1.00	1.00	1.00

Furnace	Coil	T.C.	S.C.	KW
T*(8,L)X*C20	FC/MC62D	1.00	1.00	1.00
T*9X*C20	FC/MC62D	1.00	1.00	1.00
T*9X*D20	FC/MC62D	1.00	1.00	1.00
C*(8,L)C*C20	FC/MC62D	1.00	1.00	1.00
(C*9C/T*9V)*C20	FC/MC62D	1.00	1.00	1.00
(C*9C/T*9V)*D20	FC/MC62D	1.00	1.00	1.00

COOLING PERFORMANCE DATA																
CONDENSING UNIT MODEL NO.		THRD60S41S1														
INDOOR COIL MODEL NO.		FC/MC62														
CONDENSING ENTERING AIR TEMPERATURE	IDCFM	1600					1800					2000				
	ID DB (°F)	80	80	75	80	80	80	80	75	80	80	80	80	75	80	80
	ID WB (°F)	57	62	62	67	72	57	62	62	67	72	57	62	62	67	72
65	T.C.	54.0	57.1	56.9	62.3	67.6	56.0	57.9	57.8	63.4	69.1	58.0	58.7	58.7	64.4	70.5
	S.C.	54.0	51.0	43.4	42.9	34.8	56.0	54.4	45.4	45.0	36.2	58.0	57.7	47.4	47.1	37.6
	KW	2.8	2.8	2.8	2.9	2.9	2.8	2.8	2.8	2.9	2.9	2.8	2.8	2.8	2.9	2.9
75	T.C.	51.9	54.1	53.9	59.2	64.5	53.7	54.9	54.8	60.2	65.7	55.5	55.7	55.6	61.2	66.9
	S.C.	51.9	49.8	42.0	41.7	33.5	53.7	52.7	44.1	43.8	34.8	55.5	55.6	46.1	45.8	36.2
	KW	3.2	3.2	3.2	3.3	3.3	3.2	3.2	3.2	3.3	3.3	3.2	3.2	3.2	3.3	3.3
85	T.C.	49.7	51.1	51.0	56.2	61.4	51.3	51.9	51.8	57.1	62.4	53.0	52.7	52.6	58.0	63.4
	S.C.	49.7	48.6	40.7	40.5	32.2	51.3	51.1	42.8	42.5	33.4	53.0	52.7	44.9	44.6	34.7
	KW	3.6	3.6	3.6	3.6	3.7	3.6	3.6	3.6	3.7	3.7	3.6	3.6	3.6	3.7	3.7
95	T.C.	47.6	48.1	48.1	53.1	58.3	49.0	48.9	48.8	54.0	59.0	50.4	49.7	49.5	54.8	59.8
	S.C.	47.6	47.4	39.3	39.2	30.9	49.0	48.9	41.5	41.3	32.0	50.4	49.7	43.6	43.3	33.2
	KW	4.0	4.0	4.0	4.0	4.1	4.0	4.0	4.0	4.1	4.1	4.0	4.0	4.0	4.1	4.1
105	T.C.	44.3	44.6	44.1	48.7	53.5	45.6	45.5	44.6	49.3	54.1	46.8	46.3	45.2	50.0	54.7
	S.C.	44.3	44.6	37.6	37.4	29.0	45.6	45.5	39.7	39.4	30.2	46.8	46.3	41.8	41.5	31.3
	KW	4.5	4.5	4.5	4.5	4.6	4.5	4.5	4.5	4.5	4.6	4.5	4.5	4.5	4.5	4.6
115	T.C.	41.1	41.3	40.2	44.4	48.9	42.2	42.2	40.6	44.9	49.4	43.3	43.1	41.0	45.3	49.9
	S.C.	41.1	41.3	35.9	35.7	27.3	42.2	42.2	37.9	37.7	28.4	43.3	43.1	40.0	39.7	29.5
	KW	4.9	5.0	4.9	5.0	5.0	5.0	5.0	4.9	5.0	5.0	5.0	5.0	5.0	5.0	5.0
125	T.C.	37.9	37.9	36.2	40.1	44.3	38.8	38.8	36.5	40.4	44.6	39.8	39.8	36.8	40.7	45.0
	S.C.	37.9	37.9	34.2	33.9	25.5	38.8	38.8	36.2	35.9	26.6	39.8	39.8	36.8	37.9	27.7
	KW	5.4	5.4	5.4	5.4	5.5	5.4	5.4	5.4	5.4	5.5	5.4	5.4	5.4	5.4	5.5

NOTE: ALL CAPACITIES INCLUDE INDOOR FAN HEAT AT 1250 BTUH/1000 CFM.

Multipliers for determining the performance with other indoor sections.

NOTE: For dry bulb temperatures different than those listed (between 73-87 F), sensible capacity increases by 1060 BTUH per 1000 CFM per degree above the listed temperature and decreases by 1060 BTUH per 1000 CFM per degree below the listed temperature.

Air Handler	Coil	T.C.	S.C.	KW
AHX60	—	1.01	1.00	1.00
F6FP60	—	1.01	1.00	1.00
MV20D	FC/MC62D	1.01	1.00	1.00

Furnace	Coil	T.C.	S.C.	KW
T*(8,L)X*C20	FC/MC62D	0.99	1.00	1.00
T*9X*C20	FC/MC62D	0.97	1.00	1.00
T*9X*D20	FC/MC62D	0.98	1.00	1.00
C*(8,L)C*C20	FC/MC62D	0.99	1.00	1.00
(C*9C/T*9V)*C20	FC/MC62D	0.97	1.00	1.00
(C*9C/T*9V)*D20	FC/MC62D	0.98	1.00	1.00

HEATING PERFORMANCE DATA										
CONDENSING UNIT MODEL NO		THRD18S41S1								
EVAPORATOR COIL MODEL NO		F6FP18								
AIR TEMP. ENTERING OUTDOOR UNIT	AIR TEMP. ENTERING INDOOR COIL	ID CFM								
		450			600			750		
		MBTUH	KW	C.O.P.	MBTUH	KW	C.O.P.	MBTUH	KW	C.O.P.
60	60	22.0	1.6	4.0	23.6	1.5	4.3	25.3	1.4	4.7
	70	20.6	1.6	3.6	22.2	1.6	3.9	23.7	1.5	4.3
	80	19.2	1.7	3.2	20.7	1.6	3.5	22.2	1.6	3.8
47	60	18.7	1.5	3.6	18.3	1.4	3.7	18.0	1.2	3.8
	70	17.3	1.5	3.2	17.6	1.4	3.4	18.0	1.4	3.5
	80	15.9	1.5	2.9	16.9	1.5	3.1	17.9	1.5	3.3
40	60	16.5	1.4	3.3	17.4	1.4	3.5	18.2	1.3	3.7
	70	15.3	1.4	3.0	16.2	1.4	3.2	17.1	1.4	3.4
	80	14.0	1.4	2.7	15.0	1.4	2.9	16.0	1.4	3.0
30	60	13.7	1.3	2.9	14.4	1.3	3.0	15.1	1.3	3.2
	70	12.5	1.3	2.6	13.3	1.3	2.8	14.1	1.3	2.9
	80	11.2	1.3	2.4	12.1	1.3	2.5	13.0	1.3	2.7
17	60	10.2	1.2	2.4	10.8	1.1	2.5	11.4	1.1	2.6
	70	9.0	1.1	2.2	9.6	1.1	2.3	10.2	1.1	2.4
	80	7.8	1.1	1.9	8.4	1.1	2.0	9.0	1.1	2.1
10	60	7.7	1.1	2.0	8.1	1.1	2.0	8.5	1.1	2.1
	70	7.0	1.1	1.8	7.5	1.1	1.9	7.9	1.1	1.9
	80	6.4	1.1	1.6	6.9	1.1	1.7	7.3	1.1	1.8

NOTE: ALL CAPACITIES ARE NET (KBTUH) WITH INDOOR FAN HEAT ALREADY DEDUCTED AT 1250 BTUH/1000 CFM.

Multipliers for determining the performance with other indoor sections.

Air Handler	Coil	MBH	KW	COP
AHX18	–	1.00	1.03	0.97
AHX24	–	1.00	1.03	0.98
AV*24	–	1.00	1.00	1.00
F6FP24	–	1.00	1.00	1.00
MV12B	FC/MC18B	1.00	1.00	1.00
MV12B	FC/MC24B	1.00	1.00	1.00
MV12B	FC/MC30B	1.00	1.00	1.00

Furnace	Coil	MBH	KW	COP
T*(8,L)X*A12	FC/MC/PC/UC24A	1.00	1.00	1.00
T*(8,L)X*B12	FC/MC/PC/UC24B	1.00	1.00	1.00
T*9X*B12	FC/MC/PC/UC24B	1.00	1.00	1.00
T*(8,L)X*A12	FC/MC/PC/UC30A	1.00	1.00	1.00
T*(8,L)X*B12	FC/MC/PC/UC30B	1.00	1.00	1.00
T*9X*B12	FC/MC/PC/UC30B	1.00	1.00	1.00
T*(8,L)X*A12	HC30	1.00	1.00	1.00
C*(8,L)C*A12	FC/MC/PC/UC24A	1.00	1.00	1.00
C*(8,L)C*B12	FC/MC/PC/UC24B	1.00	1.00	1.00
(C*9C/T*9V)*B12	FC/MC/PC/UC24B	1.00	1.00	1.00
C*(8,L)C*A12	FC/MC/PC/UC30A	1.00	1.00	1.00
C*(8,L)C*B12	FC/MC/PC/UC30B	1.00	1.00	1.00
(C*9C/T*9V)*B12	FC/MC/PC/UC30B	1.00	1.00	1.00
C*(8,L)C*A12	HC30	1.00	1.00	1.00

HEATING PERFORMANCE DATA										
CONDENSING UNIT MODEL NO		THRD24S41S1								
EVAPORATOR COIL MODEL NO		F6FP24								
AIR TEMP. ENTERING OUTDOOR UNIT	AIR TEMP. ENTERING INDOOR COIL	ID CFM								
		600			800			1000		
		MBTUH	KW	C.O.P.	MBTUH	KW	C.O.P.	MBTUH	KW	C.O.P.
60	60	27.6	1.8	4.3	28.9	1.7	4.6	30.2	1.6	4.9
	70	25.9	1.9	3.8	27.2	1.8	4.1	28.5	1.7	4.4
	80	24.1	2.0	3.4	25.5	1.9	3.7	26.8	1.8	3.9
47	60	22.7	1.6	3.8	23.8	1.6	4.0	24.9	1.5	4.2
	70	21.4	1.7	3.5	22.4	1.7	3.6	23.4	1.6	3.8
	80	20.1	1.8	3.1	21.0	1.7	3.3	21.8	1.7	3.4
40	60	20.3	1.6	3.6	21.0	1.5	3.7	21.8	1.5	3.8
	70	19.1	1.6	3.2	19.8	1.6	3.4	20.5	1.6	3.5
	80	17.9	1.7	2.9	18.5	1.6	3.0	19.1	1.6	3.1
30	60	15.9	1.4	3.0	17.0	1.4	3.2	18.1	1.4	3.4
	70	15.4	1.5	2.8	16.2	1.5	2.9	17.0	1.5	3.0
	80	14.9	1.6	2.6	15.4	1.5	2.7	15.8	1.5	2.7
17	60	12.8	1.3	2.6	13.5	1.3	2.7	14.2	1.3	2.8
	70	11.7	1.3	2.4	12.2	1.3	2.4	12.7	1.3	2.5
	80	10.6	1.3	2.1	10.9	1.3	2.2	11.2	1.3	2.2
10	60	1.0	1.7	0.2	6.2	1.5	1.1	11.4	1.2	2.4
	70	5.0	1.5	0.9	7.6	1.4	1.5	10.2	1.2	2.1
	80	9.0	1.2	1.9	9.1	1.2	1.9	9.1	1.2	1.9

NOTE: ALL CAPACITIES ARE NET (KBTUH) WITH INDOOR FAN HEAT ALREADY DEDUCTED AT 1250 BTUH/1000 CFM.

Multipliers for determining the performance with other indoor sections.

Air Handler	Coil	MBH	KW	COP
AHX24	—	1.00	1.01	0.99
AHX30	—	1.01	1.04	0.98
AV*24	—	1.00	1.00	1.00
MV12B	FC/MC24B	1.00	1.00	1.00
MV12B	FC/MC30B	1.00	1.00	1.00

Furnace	Coil	MBH	KW	COP
T*(8,L)X*A12	FC/MC/PC/UC24A	1.00	1.00	1.00
T*(8,L)X*B12	FC/MC/PC/UC24B	1.00	1.00	1.00
T*9X*B12	FC/MC/PC/UC24B	1.00	1.00	1.00
T*(8,L)X*A12	FC/MC/PC/UC30A	1.00	1.00	1.00
T*(8,L)X*B12	FC/MC/PC/UC30B	1.00	1.00	1.00
T*9X*B12	FC/MC/PC/UC30B	1.00	1.00	1.00
T*(8,L)X*A12	HC30	1.00	1.00	1.00
C*(8,L)C*A12	FC/MC/PC/UC24A	1.00	1.00	1.00
C*(8,L)C*B12	FC/MC/PC/UC24B	1.00	1.00	1.00
(C*9C/T*9V)*B12	FC/MC/PC/UC24B	1.00	1.00	1.00
C*(8,L)C*A12	FC/MC/PC/UC30A	1.00	1.00	1.00
C*(8,L)C*B12	FC/MC/PC/UC30B	1.00	1.00	1.00
(C*9C/T*9V)*B12	FC/MC/PC/UC30B	1.00	1.00	1.00
C*(8,L)C*A12	HC30	1.00	1.00	1.00

HEATING PERFORMANCE DATA										
CONDENSING UNIT MODEL NO		THRD30S41S1								
EVAPORATOR COIL MODEL NO		F6FP30								
AIR TEMP. ENTERING OUTDOOR UNIT	AIR TEMP. ENTERING INDOOR COIL	ID CFM								
		800			1000			1200		
		MBTUH	KW	C.O.P.	MBTUH	KW	C.O.P.	MBTUH	KW	C.O.P.
60	60	33.1	2.2	4.1	31.7	2.1	4.0	30.2	2.0	3.9
	70	31.6	2.3	3.8	31.4	2.2	3.8	31.1	2.2	3.8
	80	30.1	2.4	3.4	31.1	2.4	3.5	32.1	2.3	3.7
47	60	26.7	2.0	3.6	27.6	2.0	3.8	28.5	1.9	3.9
	70	25.5	2.1	3.3	26.3	2.1	3.4	27.1	2.0	3.5
	80	24.4	2.2	3.0	25.1	2.2	3.1	25.8	2.1	3.2
40	60	22.8	1.9	3.3	23.5	1.8	3.4	24.2	1.8	3.5
	70	22.1	2.0	3.1	22.8	1.9	3.1	23.5	1.9	3.2
	80	21.5	2.1	2.8	22.2	2.0	2.9	22.9	2.0	3.0
30	60	20.5	1.8	3.1	20.2	1.7	3.1	19.9	1.7	3.1
	70	18.9	1.8	2.8	18.8	1.8	2.8	18.7	1.7	2.8
	80	17.3	1.8	2.5	17.4	1.8	2.5	17.5	1.8	2.5
17	60	15.6	1.6	2.6	15.8	1.6	2.6	16.0	1.5	2.7
	70	13.4	1.5	2.3	14.2	1.6	2.4	15.0	1.6	2.4
	80	11.3	1.5	2.0	12.6	1.6	2.1	14.0	1.6	2.2
10	60	13.2	1.5	2.4	13.5	1.5	2.4	13.9	1.5	2.4
	70	12.0	1.5	2.1	12.3	1.5	2.1	12.5	1.5	2.1
	80	10.8	1.5	1.9	11.0	1.5	1.9	11.2	1.5	1.9

NOTE: ALL CAPACITIES ARE NET (KBTUH) WITH INDOOR FAN HEAT ALREADY DEDUCTED AT 1250 BTUH/1000 CFM.

Multipliers for determining the performance with other indoor sections.

Air Handler	Coil	MBH	KW	COP
AHX36	–	1.01	1.06	0.96
AV*36	–	1.02	1.03	0.99
F6FP36	–	1.02	1.03	0.99
MV16C	FC/MC35C	1.00	1.00	1.00
MV12B	FC/MC43B	1.02	1.03	0.99
MV16C	FC/MC43C	1.02	1.03	0.99

Furnace	Coil	MBH	KW	COP
T*(8,L)X*B12	FC/MC/PC/UC43B	1.02	1.03	0.99
T*9X*B12	FC/MC/PC/UC43B	1.02	1.03	0.99
T*(8,L)X*C16	FC/MC/PC/UC43C	1.02	1.03	0.99
T*9X*C16	FC/MC/PC/UC43C	1.02	1.03	0.99
T*(8,L)X*C16	HC42	1.02	1.03	0.99
T*9X*C16	HC42	1.02	1.03	0.99
C*(8,L)C*B12	FC/MC/PC/UC43B	1.02	1.03	0.99
(C*9C/T*9V)*B12	FC/MC/PC/UC43B	1.02	1.03	0.99
C*(8,L)C*C16	FC/MC/PC/UC43C	1.02	1.03	0.99
(C*9C/T*9V)*C16	FC/MC/PC/UC43C	1.02	1.03	0.99
C*(8,L)C*C16	HC42	1.02	1.03	0.99
(C*9C/T*9V)*C16	HC42	1.02	1.03	0.99

HEATING PERFORMANCE DATA										
CONDENSING UNIT MODEL NO		THRD36S41S1								
EVAPORATOR COIL MODEL NO		F6FP36								
AIR TEMP. ENTERING OUTDOOR UNIT	AIR TEMP. ENTERING INDOOR COIL	ID CFM								
		1000			1200			1400		
		MBTUH	KW	C.O.P.	MBTUH	KW	C.O.P.	MBTUH	KW	C.O.P.
60	60	46.1	2.7	4.4	47.6	2.6	4.8	49.0	2.5	4.8
	70	44.0	2.9	4.0	45.5	2.8	4.3	46.9	2.7	4.3
	80	42.0	3.0	3.6	43.3	2.9	3.9	44.7	2.9	3.9
47	60	38.1	2.5	4.0	39.4	2.4	4.3	40.8	2.3	4.2
	70	36.1	2.6	3.6	37.4	2.5	3.9	38.7	2.5	3.8
	80	34.2	2.7	3.2	35.4	2.7	3.5	36.6	2.6	3.4
40	60	34.0	2.4	3.7	34.9	2.3	3.9	35.7	2.2	3.8
	70	32.2	2.5	3.3	33.2	2.4	3.6	34.2	2.4	3.5
	80	30.3	2.6	3.0	31.4	2.6	3.2	32.6	2.5	3.1
30	60	27.7	2.2	3.1	28.8	2.2	3.4	29.8	2.1	3.3
	70	26.5	2.3	2.9	27.4	2.3	3.1	28.2	2.2	3.0
	80	25.3	2.4	2.7	26.0	2.4	2.9	26.6	2.3	2.7
17	60	21.5	2.0	2.7	22.2	2.0	2.9	23.0	2.0	2.7
	70	20.2	2.0	2.5	20.9	2.0	2.7	21.6	2.0	2.5
	80	19.0	2.1	2.3	19.6	2.1	2.4	20.3	2.0	2.3
10	60	18.7	1.9	2.5	19.3	1.9	2.6	19.9	1.9	2.5
	70	17.2	1.9	2.2	17.8	1.9	2.4	18.5	1.9	2.3
	80	15.7	1.9	2.0	16.3	1.9	2.2	17.0	1.9	2.1

NOTE: ALL CAPACITIES ARE NET (KBTUH) WITH INDOOR FAN HEAT ALREADY DEDUCTED AT 1250 BTUH/1000 CFM.

Multipliers for determining the performance with other indoor sections.

Air Handler	Coil	MBH	KW	COP
AHX36	-	1.01	1.06	0.96
AV*36	-	1.03	1.06	1.00
MV16C	FC/MC35C	1.00	1.00	1.00
MV16C	FC/MC43C	1.03	1.06	1.00

Furnace	Coil	MBH	KW	COP
T*(8,L)X*C16	FC/MC/PC/UC43C	1.03	1.06	1.00
T*9X*C16	FC/MC/PC/UC43C	1.03	1.06	1.00
T*(8,L)X*C20	FC/MC/PC/UC43C	1.03	1.06	1.00
T*9X*C20	FC/MC/PC/UC43C	1.03	1.06	1.00
T*(8,L)X*C16	HC42	1.03	1.06	1.00
T*9X*C16	HC42	1.03	1.06	1.00
T*(8,L)X*C20	HC42	1.03	1.06	1.00
T*9X*C20	HC42	1.03	1.06	1.00
C*(8,L)C*C16	FC/MC/PC/UC43C	1.03	1.06	1.00
(C*9C/T*9V)*C16	FC/MC/PC/UC43C	1.03	1.06	1.00
C*(8,L)C*C20	FC/MC/PC/UC43C	1.03	1.06	1.00
(C*9C/T*9V)*C20	FC/MC/PC/UC43C	1.03	1.06	1.00
C*(8,L)C*C16	HC42	1.03	1.06	1.00
(C*9C/T*9V)*C16	HC42	1.03	1.06	1.00
C*(8,L)C*C20	HC42	1.03	1.06	1.00
(C*9C/T*9V)*C20	HC42	1.03	1.06	1.00

HEATING PERFORMANCE DATA										
CONDENSING UNIT MODEL NO		THRD42S41S1								
EVAPORATOR COIL MODEL NO		F6FP42								
AIR TEMP. ENTERING OUTDOOR UNIT	AIR TEMP. ENTERING INDOOR COIL	ID CFM								
		1200			1400			1600		
		MBTUH	KW	C.O.P.	MBTUH	KW	C.O.P.	MBTUH	KW	C.O.P.
60	60	47.6	4.6	2.7	47.5	4.7	2.6	47.5	4.8	2.5
	70	46.0	4.3	2.9	46.4	4.3	2.8	46.7	4.4	2.7
	80	44.4	3.9	3.1	45.2	4.0	3.0	46.0	4.1	2.9
47	60	41.6	4.3	2.6	42.2	4.4	2.5	42.9	4.5	2.4
	70	39.8	3.9	2.7	40.7	4.0	2.6	41.6	4.1	2.6
	80	38.0	3.6	2.8	39.1	3.7	2.8	40.3	3.8	2.8
40	60	37.8	4.1	2.4	38.9	4.2	2.4	39.9	4.3	2.4
	70	36.1	3.7	2.6	37.1	3.8	2.5	38.1	3.9	2.5
	80	34.4	3.4	2.7	35.4	3.5	2.6	36.4	3.6	2.6
30	60	32.1	3.7	2.3	32.5	3.7	2.2	32.8	3.7	2.2
	70	30.6	3.4	2.4	31.2	3.4	2.4	31.8	3.4	2.3
	80	29.1	3.1	2.5	29.9	3.1	2.5	30.8	3.2	2.4
17	60	25.9	3.1	2.1	26.5	3.2	2.1	27.2	3.2	2.1
	70	24.4	2.9	2.2	25.1	2.9	2.2	25.7	3.0	2.2
	80	23.0	2.6	2.3	23.6	2.7	2.2	24.3	2.7	2.2
10	60	21.9	2.8	2.0	21.8	2.8	2.0	21.7	2.7	1.9
	70	19.7	2.5	2.0	20.0	2.5	2.0	20.3	2.5	2.0
	80	17.5	2.2	2.0	18.2	2.3	2.0	18.9	2.3	2.0

NOTE: ALL CAPACITIES ARE NET (KBTUH) WITH INDOOR FAN HEAT ALREADY DEDUCTED AT 1250 BTUH/1000 CFM.

Multipliers for determining the performance with other indoor sections.

Air Handler	Coil	MBH	KW	COP
AHX42	—	0.98	1.01	0.98
AHX48	—	0.99	1.01	0.98
AV*48	—	1.01	1.01	1.00
AV*60	—	1.01	1.01	1.00
F6FP48	—	1.01	1.01	1.00
MV16C	FC/MC48C	1.00	1.00	1.00
MV20D	FC/MC48D	1.00	1.00	1.00
MV16C	FC/MC60C	1.01	1.01	1.00
MV20D	FC/MC60D	1.01	1.01	1.00

Furnace	Coil	MBH	KW	COP
T*(8,L)X*C16	FC/MC/PC/UC48C	1.00	1.00	1.00
T*9X*C16	FC/MC/PC/UC48C	1.00	1.00	1.00
T*(8,L)X*C20	FC/MC/PC/UC48C	1.00	1.00	1.00
T*9X*C20	FC/MC/PC/UC48C	1.00	1.00	1.00
T*9X*D20	FC/MC/PC/UC48D	1.00	1.00	1.00
T*(8,L)X*C16	FC/PC/UC60C	1.01	1.01	1.00
T*9X*C16	FC/PC/UC60C	1.01	1.01	1.00
T*(8,L)X*C20	FC/PC/UC60C	1.01	1.01	1.00
T*9X*C20	FC/PC/UC60C	1.01	1.01	1.00
T*9X*D20	FC/MC/PC/UC60D	1.01	1.01	1.00
T*9X*D20	HC60	1.01	1.01	1.00
C*(8,L)C*C16	FC/MC/PC/UC48C	1.00	1.00	1.00
(C*9C/T*9V)*C16	FC/MC/PC/UC48C	1.00	1.00	1.00
C*(8,L)C*C20	FC/MC/PC/UC48C	1.00	1.00	1.00
(C*9C/T*9V)*C20	FC/MC/PC/UC48C	1.00	1.00	1.00
(C*9C/T*9V)*D20	FC/MC/PC/UC48D	1.00	1.00	1.00
C*(8,L)C*C16	FC/PC/UC60C	1.01	1.01	1.00
(C*9C/T*9V)*C16	FC/PC/UC60C	1.01	1.01	1.00
C*(8,L)C*C20	FC/PC/UC60C	1.01	1.01	1.00
(C*9C/T*9V)*C20	FC/PC/UC60C	1.01	1.01	1.00
(C*9C/T*9V)*D20	FC/MC/PC/UC60D	1.01	1.01	1.00
(C*9C/T*9V)*D20	HC60	1.01	1.01	1.00

HEATING PERFORMANCE DATA										
CONDENSING UNIT MODEL NO		THRD48S41S1								
EVAPORATOR COIL MODEL NO		F6FP48								
AIR TEMP. ENTERING OUTDOOR UNIT	AIR TEMP. ENTERING INDOOR COIL	ID CFM								
		1400			1600			1800		
		MBTUH	KW	C.O.P.	MBTUH	KW	C.O.P.	MBTUH	KW	C.O.P.
60	60	54.5	3.0	4.7	53.4	2.9	4.7	52.4	2.8	4.6
	70	53.4	3.3	4.3	53.5	3.2	4.3	53.6	3.1	4.4
	80	52.4	3.6	3.9	53.6	3.5	4.0	54.9	3.4	4.1
47	60	48.5	2.9	4.4	49.5	2.8	4.4	50.5	2.8	4.5
	70	46.4	3.1	3.9	47.2	3.1	3.9	48.1	3.2	3.9
	80	44.2	3.3	3.6	44.9	3.4	3.5	45.6	3.5	3.3
40	60	43.1	2.8	4.0	44.2	2.7	4.1	45.2	2.7	4.2
	70	40.0	2.9	3.6	41.6	2.9	3.7	43.2	2.9	3.8
	80	36.9	3.0	3.2	39.1	3.0	3.3	41.3	3.0	3.4
30	60	36.4	2.6	3.6	37.2	2.6	3.7	38.1	2.5	3.7
	70	34.5	2.7	3.3	35.4	2.7	3.3	36.2	2.7	3.4
	80	32.7	2.8	3.0	33.5	2.8	3.0	34.3	2.8	3.1
17	60	28.9	0.0	22.6	29.5	1.2	5.4	30.2	2.3	3.1
	70	27.3	1.3	4.9	27.7	1.8	3.6	28.1	2.4	2.9
	80	25.8	2.5	2.6	25.9	2.5	2.6	26.0	2.5	2.6
10	60	24.8	2.2	2.8	25.3	2.3	2.8	25.9	2.3	2.8
	70	23.1	2.3	2.5	23.6	2.3	2.5	24.1	2.3	2.5
	80	21.4	2.4	2.3	21.8	2.4	2.3	22.3	2.4	2.3

NOTE: ALL CAPACITIES ARE NET (KBTUH) WITH INDOOR FAN HEAT ALREADY DEDUCTED AT 1250 BTUH/1000 CFM.

Multipliers for determining the performance with other indoor sections.

Air Handler	Coil	MBH	KW	COP
MV20D	FC/MC60D	1.00	1.00	1.00
MV20D	FC/MC62D	1.00	1.00	1.00
AHX48	—	0.98	0.99	0.99
AHX60	—	0.99	0.99	1.00
AV48	—	1.00	1.00	1.00
AV60	—	1.00	1.00	1.00
F6FP60	—	1.00	1.00	1.00

Furnace	Coil	MBH	KW	COP
T*(8,L)*C20	FC/MC62D	1.00	1.00	1.00
T*9X*C20	FC/MC62D	1.00	1.00	1.00
T*9X*D20	FC/MC62D	1.00	1.00	1.00
C*(8,L)*C20	FC/MC62D	1.00	1.00	1.00
(C*9C/T*9V)*C20	FC/MC62D	1.00	1.00	1.00
(C*9C/T*9V)*D20	FC/MC62D	1.00	1.00	1.00

HEATING PERFORMANCE DATA										
CONDENSING UNIT MODEL NO		THRD60S41S1								
EVAPORATOR COIL MODEL NO		FC/MC62								
AIR TEMP. ENTERING OUTDOOR UNIT	AIR TEMP. ENTERING INDOOR COIL	ID CFM								
		1600			1800			2000		
		MBTUH	KW	C.O.P.	MBTUH	KW	C.O.P.	MBTUH	KW	C.O.P.
60	60	65.7	4.7	4.1	66.7	4.6	4.2	67.6	4.6	4.3
	70	64.7	5.1	3.7	65.4	5.0	3.8	66.1	4.9	3.9
	80	63.8	5.5	3.4	64.1	5.4	3.5	64.5	5.3	3.6
47	60	56.9	4.4	3.8	57.4	4.4	3.9	58.0	4.3	4.0
	70	55.8	4.8	3.4	56.3	4.8	3.5	56.8	4.7	3.5
	80	54.7	5.2	3.1	55.2	5.2	3.1	55.6	5.1	3.2
40	60	51.9	4.3	3.5	51.7	4.3	3.5	51.4	4.3	3.5
	70	50.6	4.8	3.1	51.1	4.7	3.2	51.7	4.7	3.2
	80	49.3	5.2	2.8	50.6	5.1	2.9	51.9	5.0	3.0
30	60	44.1	5.0	2.6	43.6	5.0	2.5	43.1	5.0	2.5
	70	45.3	4.6	2.9	44.8	4.6	2.9	44.4	4.6	2.8
	80	46.5	4.2	3.2	46.1	4.2	3.2	45.6	4.1	3.2
17	60	36.6	5.0	2.2	36.8	4.9	2.2	36.9	4.9	2.2
	70	36.0	4.5	2.4	36.5	4.5	2.4	37.1	4.4	2.4
	80	35.3	4.0	2.6	36.3	4.0	2.6	37.3	4.0	2.7
10	60	27.3	4.7	1.7	27.7	4.6	1.7	28.1	4.6	1.8
	70	30.4	4.4	2.0	31.2	4.3	2.1	32.0	4.3	2.2
	80	33.4	4.0	2.4	34.7	4.0	2.5	35.9	4.0	2.7

NOTE: ALL CAPACITIES ARE NET (KBTUH) WITH INDOOR FAN HEAT ALREADY DEDUCTED AT 1250 BTUH/1000 CFM.

Multipliers for determining the performance with other indoor sections.

Air Handler	Coil	MBH	KW	COP
AHX60	–	1.00	1.00	1.00
F6FP60	–	1.00	1.00	1.00
MV20D	FC/MC62D	1.00	1.00	1.00

Furnace	Coil	MBH	KW	COP
T*(8,L)X*C20	FC/MC62D	0.98	0.98	1.00
T*9X*C20	FC/MC62D	0.99	0.97	1.03
T*9X*D20	FC/MC62D	0.99	0.99	1.00
C*(8,L)C*C20	FC/MC62D	0.98	0.98	1.00
(C*9C/T*9V)*C20	FC/MC62D	0.99	0.97	1.03
(C*9C/T*9V)*D20	FC/MC62D	0.99	0.99	1.00

