

SUBMITTAL DATA SHEET

CONDENSING MULTI-POSITION SINGLE-STAGE GAS FURNACES MODELS: TM8X/TMLX

JOB NAME:		LOCATION:		
PURCHASER:		ORDER NO:		
ENGINEER:				
SUBMITTED TO:	FOR:	REF:	APPROVAL:	CONSTRUCTION:
SUBMITTED BY:		DATE:		
UNIT DESIGNATION:		SCHEDULE NO.		MODEL NO.

DIMENSIONS - INCHES

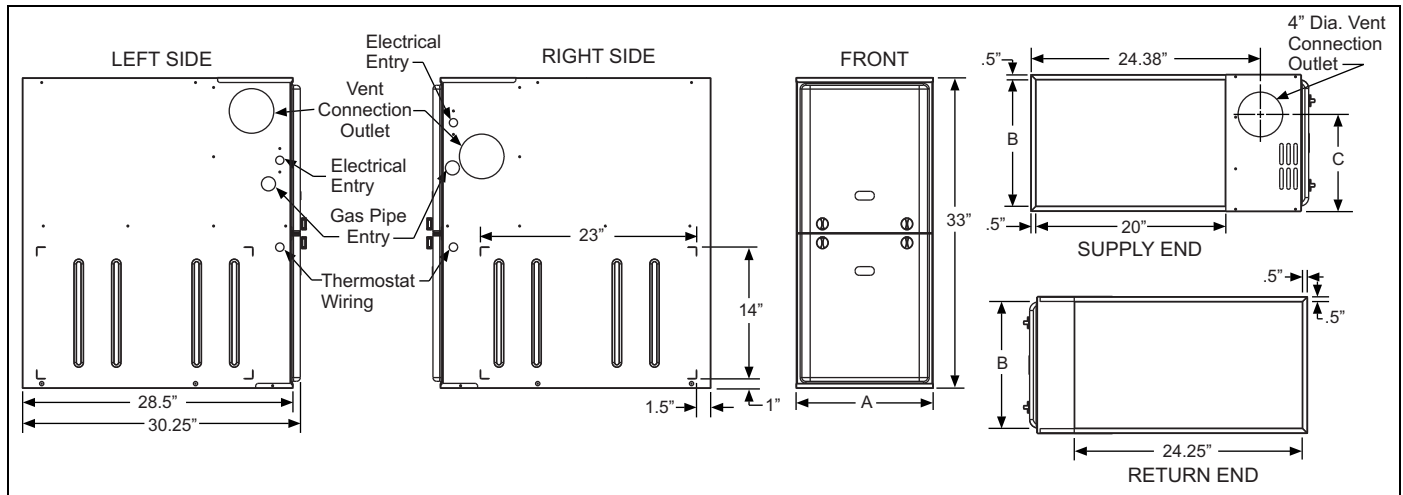

BTUH (kW) Input	Nominal CFM	Cabinet Size	Cabinet Dimensions (Inches)			Approximate Operating Weights
			A	B	C	Lbs
TM(8,L)X060A12MP11	1200	A	14 1/2	13 3/8	10.3	94
TM(8,L)X080B12MP11	1200	B	17 1/2	16 3/8	11.8	103
TM(8,L)X080C16MP11	1600	C	21	19 7/8	13.6	114
TM(8,L)X100C16MP11	1600	C	21	19 7/8	13.6	118
TM(8,L)X100C20MP11	2000	C	21	19 7/8	13.6	122
TM(8,L)X120C20MP11	2000	C	21	19 7/8	15.8	129

Due to continuous product improvements, specifications are subject to change without notice. Installation and conversions of these furnaces must be made by qualified distributor, dealer, or contractor personnel.

PRODUCT DATA

Heating Performance

Input Capacity _____ MBH
 Output Capacity _____ MBH
 Air Temp. Rise _____ °F

Supply Air Blower Performance

Total Supply Air _____ CFM
 Total External Static Pressure _____ IWG
 Blower Speed (circle) ____ HI MH ML L
 Motor Rating _____ HP

Electrical Data

Power Supply _____ / /
 Total Unit Ampacity _____ AMPS
 Minimum Wire Size _____ AWG
 Maximum Overcurrent Device
 Fuses Circuit Breaker _____ AMPS

Unit Weight

Total Unit Weight _____ LBS



FEATURES

- Easily applied in upflow, horizontal left or right, or downflow installation with minimal conversion necessary.
- Compact, easy to install, ideal height 33" tall cabinet.
- Blower-off delay for cooling SEER improvement.
- Easy access to controls to connect power/control wiring.
- Built-in, high level self diagnostics with fault code displays standard on integrated control module for reliable operation.
- Low unit amp requirement for easy replacement application.
- All models are convertible to use propane (LP) gas.
- Electronic Hot Surface Ignition saves fuel cost with increased dependability and reliability.
- 100% shut off main gas valve for extra safety.
- 5 speed X13 direct drive style high efficiency DC motor.
- 24V, 40 VA control transformer and blower relay supplied for add-on cooling.
- Hi-tech tubular aluminized steel primary heat exchanger.
- Timed on, adjustable off blower capability for maximum comfort.
- Blower door safety switch.
- Solid removable bottom panel allows easy conversion.
- Low NOx models have been designed to meet specific code requirements.
- Airflow leakage less than 1% of total airflow at ductblaster conditions.
- No knockouts to deal with, making installation easier.
- Movable duct connector flanges for application flexibility.
- Quiet inducer operation.
- Inducer rotates for easy conversion of venting options.
- Fully supported blower assembly for easy access and removal of blower.
- External air filters used for maximum flexibility in meeting customers IAQ needs.
- Venting applications - may be installed as a common vent with other gas-fired appliances or use a masonry chimney.
- 1/4 turn knobs provided for easy door removal.
- High-efficiency blower motor for lower electrical power usage and improved A/C SEER ratings.
- Insulated blower compartment for thermal and acoustic performance.

FIELD INSTALLED ACCESSORIES

PROPANE (LP) CONVERSION KIT -

1NP0347 - All Models

This accessory conversion kit may be used to convert natural gas units for propane (LP) operation.

SIDE RETURN FILTER RACKS -

1SR0200 - All Models

1SR0302 - All Models

BOTTOM RETURN FILTER RACKS -

1BR0514 or 1BR0614 - For 14-1/2" cabinets

1BR0517 or 1BR0617 - For 17-1/2" cabinets

1BR0521 or 1BR0621 - For 21" cabinets

1BR05xx series are galvanized steel filter racks. 1BR06xx are pre-painted steel filter racks to match the appearance of the furnace cabinet.

COMBUSTIBLE FLOOR BASE KIT -

For installation of these furnaces in downflow applications directly onto combustible flooring material. These kits are required to prevent potential overheating situations. These kits are also required in any applications where the furnace is installed in a downflow configuration without an evaporator coil, where the combustible floor base kit provides access for combustible airflow.

1CB0514 - For 14-1/2" cabinets

1CB0517 - For 17-1/2" cabinets

1CB0521 - For 21" cabinets

EAC TRANSITION KITS -

For installation of EAC accessories with these furnaces to provide easy transition of return airflow through the EAC to get the proper sealing and reduced airflow leakage.

1TK1001 - For all models using side return

1TK1014 - For 14-1/2" cabinets using bottom return

1TK1017 - For 17-1/2" cabinets using bottom return

1TK1021 - For 21" cabinets using bottom return

MASONRY CHIMNEY KITS -

1CK0603

1CK0604

For installations where these furnaces are vented using existing or new lined masonry chimneys.

HIGH ALTITUDE PRESSURE SWITCHES -

For installation where the altitude is less than 5,000 feet it is not required that the pressure switch be changed. For altitudes above 5,000 feet, see kits below.

1PS3301

1PS3302