

# SUBMITTAL DATA SHEET

## SINGLE PIECE AIR HANDLER SPLIT-SYSTEM FAN COIL MODELS: AHX SERIES

JOB NAME:			LOCATION:		
PURCHASER:			ORDER NO:		
ENGINEER:					
SUBMITTED TO:		FOR:	REF:	APPROVAL:	CONSTRUCTION:
SUBMITTED BY:			DATE:		
UNIT DESIGNATION:			SCHEDULE NO.	MODEL NO.	

### PRODUCT DATA

#### Cooling Performance

Total Capacity\* \_\_\_\_\_ MBH  
 Sensible Capacity\* \_\_\_\_\_ MBH  
 Temperature of Air Entering  
 Indoor Coil \_\_\_\_\_ °F (DB/WB)

#### Supply Air Blower Performance

Total Supply Air \_\_\_\_\_ CFM  
 Total External Static  
 Pressure \_\_\_\_\_ IWG  
 Blower Speed Settings \_\_\_\_\_  
 Motor Rating \_\_\_\_\_ HP  
 Power Input Requirement \_\_\_\_\_ KW

#### Electrical Data

Power Supply \_\_\_\_\_ / \_\_\_\_\_ / \_\_\_\_\_  
 Total Unit Ampacity \_\_\_\_\_ AMPS  
 Minimum Wire Size \_\_\_\_\_ AWG  
 (Copper conductors)  
 Maximum Overcurrent Device  
 Fuses (Dual Element)  
 Circuit Breaker (HACR)

#### Unit Weight

Total Unit Weight \_\_\_\_\_ LBS  
 (Include field-installed accessories)

#### Options

Field Installed TXV

\* Shown in Outdoor Unit Technical Guide

### CLEARANCES

Front	24"
Rear	0"*
Sides	0"*

\* 0 Clearance allowed with or without Electric Heater.

### FEATURES

- Cooling or Heat Pump Applications
- Durable pre-painted galvanized steel cabinet
- 4-Way Position Models
- Multi-position models easily converted, on Downflow and Horizontal Left
- Composite drain pan for added strength
- "Flex Coil" with field installed TXV on all models
- Rifled Copper tube and Microblue™ coated aluminum fin
- Direct drive 5 speed, high-efficiency brushless DC motor
- Slide out blower and coil for service access
- Easily installed electric heaters available (1&3ph) 4HK Series
- Thermally insulated with 1" foil faced insulation (R-4.2)
- Factory sealed to achieve 2% or less total air leakage
- Factory provided filter rack for all models except for AHX60 size, which requires an external filter rack.

### FIELD INSTALLED ACCESSORIES

- Insulated Air Handler Cover (# \_\_\_\_\_)
- Electric Heaters (#4HK \_\_\_\_\_)  
 Capacity (@ \_\_\_\_\_ Volts) \_\_\_\_\_ MBH  
 Power Input Requirement (Less Blower Motor) \_\_\_\_\_ KW
- Thermal Expansion / Check Valve Kit (# \_\_\_\_\_)
- Combustible Floor Base (# \_\_\_\_\_)

### MATCHED OUTDOOR UNIT

- Model Number (# \_\_\_\_\_)
- Submittal Part Number (# \_\_\_\_\_)



## DIMENSIONS - INCHES

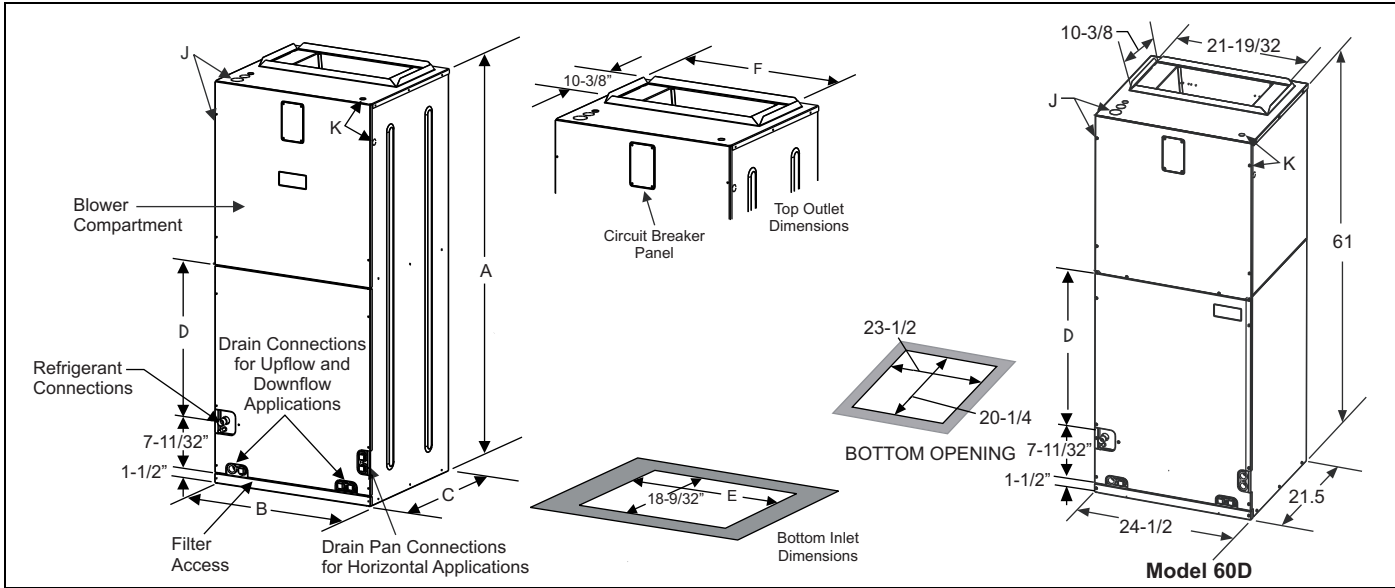

### Dimensions

MODELS	Dimensions						Wiring Knockouts <sup>1</sup>		Refrigerant Connections Line Size	
	A	B	C	D	E	F	J	K	Liquid	Vapor
	Height	Width	Depth				Power	Control		
AHX18B3XH21	46"	17-1/2"	21-1/2"	12-3/8"	13-29/32"	14-19/32"	7/8" (1/2") 1 3/8" (1") 1 23/32" (1 1/4")	7/8" (1/2")	3/8"	3/4"
AHX24B3XH21	46"	17-1/2"	21-1/2"	12-3/8"	13-29/32"	14-19/32"	7/8" (1/2") 1 3/8" (1") 1 23/32" (1 1/4")	7/8" (1/2")	3/8"	3/4"
AHX30B3XH21	46"	17-1/2"	21-1/2"	12-3/8"	13-29/32"	14-19/32"	7/8" (1/2") 1 3/8" (1") 1 23/32" (1 1/4")	7/8" (1/2")	3/8"	3/4"
AHX36C3XH21	52"	21"	21-1/2"	17-1/8"	17-13/32"	18-3/32"	7/8" (1/2") 1 3/8" (1") 1 23/32" (1 1/4")	7/8" (1/2")	3/8"	7/8"
AHX42D3XH21	57"	24-1/2"	21-1/2"	22-1/8"	20-29/32"	21-19/32"	7/8" (1/2") 1 3/8" (1") 1 23/32" (1 1/4")	7/8" (1/2")	3/8"	7/8"
AHX48D3XH21	57"	24-1/2"	21-1/2"	22-1/8"	20-29/32"	21-19/32"	7/8" (1/2") 1 3/8" (1") 1 23/32" (1 1/4")	7/8" (1/2")	3/8"	7/8"
AHX60D3XH21	61"	24-1/2"	21-1/2"	26-1/8"	23-1/2"	21-19/32"	7/8" (1/2") 1 3/8" (1") 1 23/32" (1 1/4")	7/8" (1/2")	3/8"	7/8"

1. Actual size (Conduit size).