

JOB NAME _____ LOCATION _____
 PURCHASER _____ ORDER NO. _____
 ENGINEER _____
 SUBMITTED TO _____ FOR: Reference Approval Construction
 SUBMITTED BY _____ DATE _____

UNIT DESIGNATION: Schedule No. _____ MODEL NO. _____

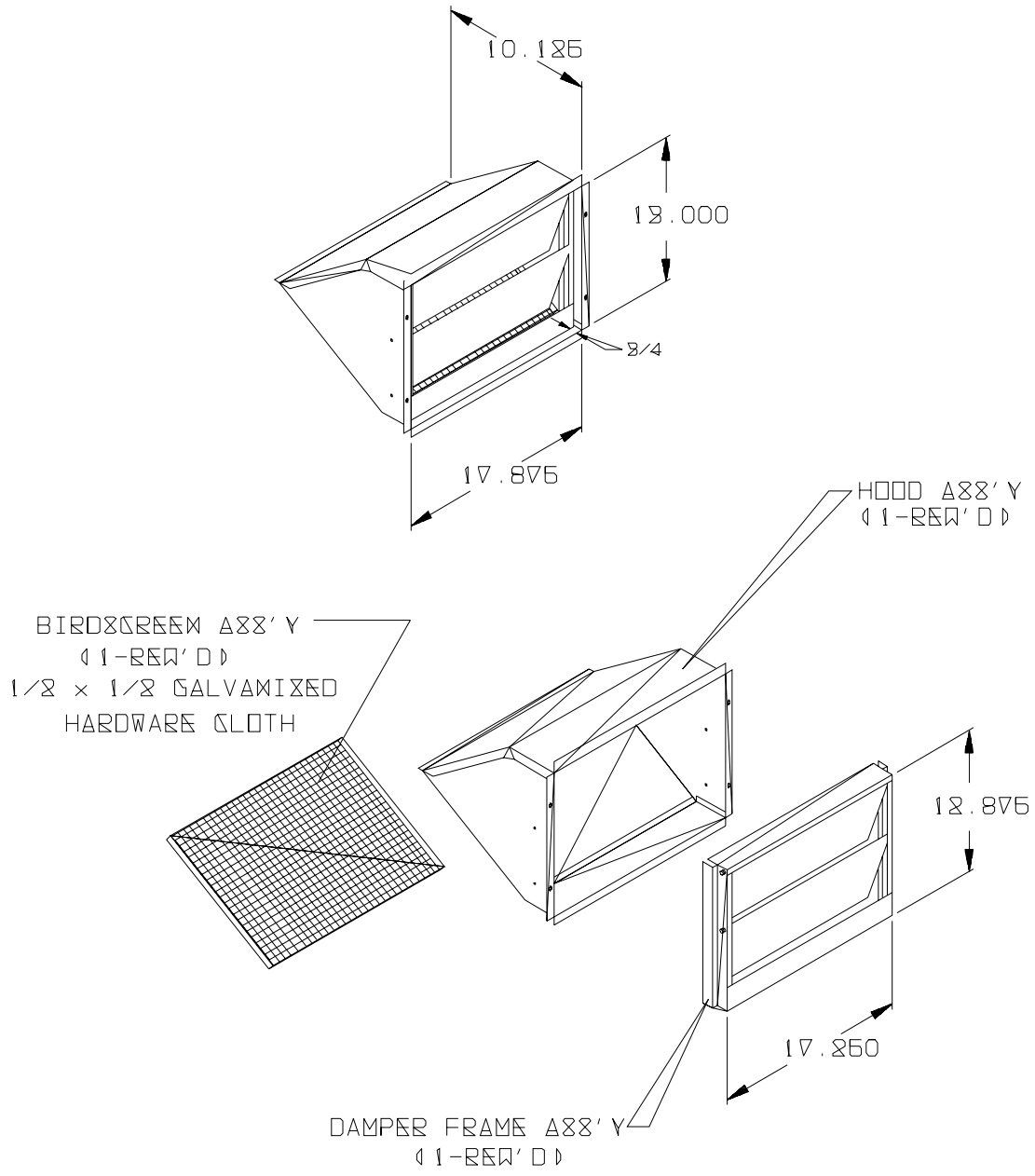

- SPECIFICATIONS: 1. Made of 24 gauge G-90 galvanized paint grip.
 2. Blades made of .032 thick, 5052 aluminum.
 3. Painted with electromagnetic power paint to match the unit.

NOTE: Barometric capability based on .3 IWG pressure at damper blades.

Subject to change without notice. Printed in the U. S. A.

**0 - 100% BAROMETRIC RELIEF DAMPER
 MODEL 1RD0410 (3 - 6 TON)**

For Units: BCB BDF
 DHB DUC
 DHC DUS

FORM 530.18-SD25C-0202

Supersedes: Nothing

