

# TABULAR DATA SHEET



## Outdoor Split System Heat Pump 2 Thru 5 Tons

MODELS: HC8B024\* THRU 060\*(C)  
18 SEER – R-410A

### Physical and Electrical Data

MODEL	HC8B024F3(C)	HC8B036F3(C)	HC8B048F3(C)	HC8B060F3(C)
Unit Supply Voltage	208-230V, 1 $\phi$ , 60Hz			
Normal Voltage Range <sup>1</sup>	187 to 252			
Minimum Circuit Ampacity	18.2	23.6	29.2	34.8
Max. Overcurrent Device Amps <sup>2</sup>	30	40	50	60
Min. Overcurrent Device Amps <sup>3</sup>	20	25	30	35
Multi-stage Compressor	Yes	Yes	Yes	Yes
Compressor Type	Scroll	Scroll	Scroll	Scroll
Compressor Amps	Rated Load	12.3	16.6	21.1
	Locked Rotor	52	82	96
Crankcase Heater	No	No	No	No
Fan Motor Amps	Rated Load	2.8	2.8	2.8
	Fan Diameter Inches	24	24	24
Fan Motor	Rated HP	1/3	1/3	1/3
	Nominal RPM	685	685	685
	Nominal CFM	2,940	2,666	3,376
Coil	Face Area Sq. Ft.	23.58	23.58	23.58
	Rows Deep	2	2	2
	Fins / Inch	16	16	14
Liquid Line Set OD (Field Installed)	3/8	3/8	3/8	3/8
Vapor Line Set OD (Field Installed)	3/4	3/4	7/8	7/8
Unit Charge (Lbs. - Oz.) <sup>4</sup>	14 - 12	12 - 7	12 - 13	14 - 8
Charge Per Foot, Oz.	0.62	0.62	0.67	0.67
Operating Weight Lbs.	275	275	280	315

1. Rated in accordance with ARI Standard 110, utilization range "A".
2. Dual element fuses or HACR circuit breaker. Maximum allowable overcurrent protection.
3. Dual element fuses or HACR circuit breaker. Minimum recommended overcurrent protection.
4. The Unit Charge is correct for the outdoor unit, matched indoor coil and 15 feet of refrigerant tubing. For tubing lengths other than 15 feet, add or subtract the amount of refrigerant, using the difference in length multiplied by the per foot value.

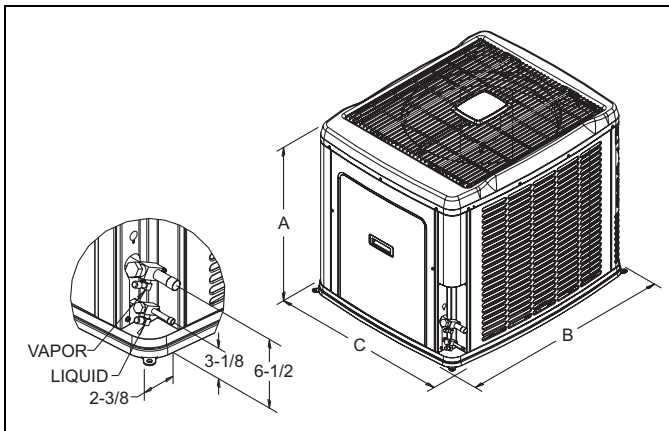

All dimensions are in inches. They are subject to change without notice. Certified dimensions will be provided upon request.

Unit Model	Dimensions (Inches)			Refrigerant Connection Service Valve Size	
	A	B	C	Liquid	Vapor
024	39-1/2	42	34	3/8"	3/4"
036	39-1/2	42	34		
048	39-1/2	42	34		7/8"
060	39-1/2	42	34		

System Charge for Various Matched Systems				
Outdoor Unit	HC8B024F3(C)	HC8B036F3(C)	HC8B048F3(C)	HC8B060F3(C)
Approved System Thermal Expansion Valve <sup>1</sup>	1TVM4G1	1TVM4G1	1TVM4H1	1TVM4K1
Factory R-410A Charge, lbs-oz	14 - 12	12 - 7	12 - 13	14 - 8
<b>Indoor Coil<sup>2</sup></b>	<b>TXV Kit<sup>3</sup> - Additional Charge, Oz</b>			
AHX36	0	0	-	-
AHX48	-	9	4	-
AHX60	-	-	7	7
AV36	0	0	-	-
AV/SV48	-	9	4	-
AV/SV60	-	-	4	0
FC/MC/PC37A	0	0	-	-
FC/MC/PC43BC	0	0	-	-
FC/MC/PC48CD	5	5	0	-
FC/MC/PC60CD	9	9	4	0
FC/MC62D	-	16	7	7
FC64D	-	25	15	14
HC42	0	0	-	-
HC60	-	-	4	0
HD48	-	5	0	-
HD60	-	-	4	0

**FOOTNOTES:**

1. Systems matched with furnace or air handlers not equipped with blower-off delays may require blower Time Delay Kit 2FD06700224.
2. PC coils cannot be used in downflow or horizontal applications. FC coils cannot be used in horizontal applications.
3. A TXV kit must be used with these coils to obtain system performance.

**Note:** If a TXV is factory installed on the coil, it must be replaced with the listed TXV.

**PROCEDURES:**

1. Unit factory charge listed on the unit nameplate includes refrigerant for the condenser, the smallest evaporator and 15 feet of interconnecting line tubing.
2. Verify the TXV and additional charge required for specific evaporator coil in the system using the above table.
3. Additional charge for the amount of interconnecting line tubing greater than 15 feet at the rate specified in the Physical and Electrical Data Table.
4. Permanently mark the unit nameplate with the total system charge. Total System Charge = Base Charge (as shipped) + adder for evaporator + adder for line set.

