

TABULAR DATA SHEET

Outdoor Split System Heat Pump 1.5 Thru 5 Tons

MODELS: THGD18* THRU 60

13 SEER – R-410A, 1 PHASE

Physical and Electrical Data

MODEL	THGD18 S41S3	THGD24 S41S4	THGD30 S41S4	THGD36 S41S4	THGD42 S41S4	THGD48 S41S4	THGD60 S41S4
Unit Supply Voltage	208-230V, 1 ϕ , 60Hz						
Normal Voltage Range ¹	187 to 252						
Minimum Circuit Ampacity	11.9	11.2	14.1	19.7	20.9	25.6	34.9
Max. Overcurrent Device Amps ²	20	15	20	30	35	45	60
Min. Overcurrent Device Amps ³	15	15	15	20	25	30	35
Compressor Type	Scroll	Recip	Recip	Recip	Recip	Recip	Scroll
Compressor Amps	Rated Load	9.0	8.3	10.6	14.7	15.7	26.9
	Locked Rotor	48.0	43.0	54.0	74.0	88.0	135.0
Crankcase Heater	No	Yes	Yes	Yes	Yes	Yes	No
Fan Motor Amps	Rated Load	0.70	0.80	0.80	1.3	1.3	1.3
Fan Diameter Inches	24	24	24	24	24	24	24
Fan Motor	Rated HP	1/10	1/8	1/8	1/4	1/4	1/4
	Nominal RPM	825	1075	1075	850	850	850
	Nominal CFM	2000	2900	3000	3800	3800	3600
Coil	Face Area Sq. Ft.	15.7	18.3	21.0	23.6	23.6	23.6
	Rows Deep	1	1	1	1	1	2
	Fin / Inches	22	22	22	22	22	18
Liquid Line Set OD (Field Installed)	3/8	3/8	3/8	3/8	3/8	3/8	3/8
Vapor Line Set OD (Field Installed)	3/4	3/4	3/4	3/4	7/8	7/8	7/8
Unit Charge (Lbs. - Oz.) ⁴	6 - 6	9 - 6	9 - 0	10 - 0	9 - 10	14 - 12	13 - 13
Charge Per Foot, Oz.	0.62	0.62	0.62	0.62	0.67	0.67	0.67
Operating Weight Lbs.	172	194	206	218	218	285	284

1. Rated in accordance with ARI Standard 110, utilization range "A".
2. Dual element fuses or HACR circuit breaker. Maximum allowable overcurrent protection.
3. Dual element fuses or HACR circuit breaker. Minimum recommended overcurrent protection.
4. The Unit Charge is correct for the outdoor unit, matched indoor coil and 15 feet of refrigerant tubing. For tubing lengths other than 15 feet, add or subtract the amount of refrigerant, using the difference in length multiplied by the per foot value.

All dimensions are in inches. They are subject to change without notice. Certified dimensions will be provided upon request.

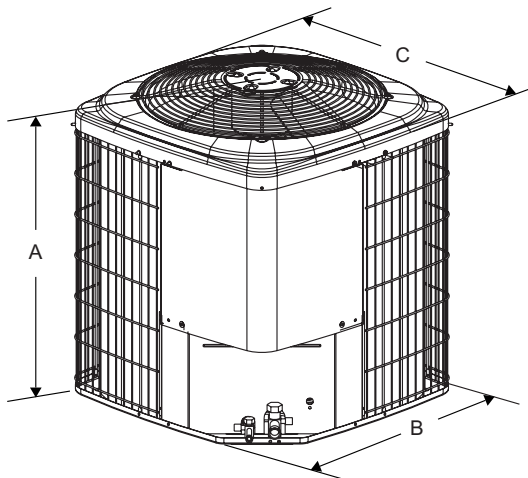

Unit Model	Dimensions (Inches)			Refrigerant Connection Service Valve Size	
	A ¹	B	C	Liquid	Vapor
18	28	34	34	3/8"	3/4"
24	32	34	34		
30	36	34	34		
36	40	34	34		
42	40	34	34		
48	40	34	34	7/8"	
60	40	34	34		

1. Including Fan Guard.

System Charge for Various Matched Systems

Outdoor Unit	THGD18S41S3	THGD24S41S4	THGD30S41S4	THGD36S41S4	THGD42S41S4	THGD48S41S4	THGD60S41S4
Required Orifice or TXV ¹	.051/4F1	.054/4G1	.063/4G1	.071/4H1	.075/4H1	4J1	4K1
Factory Charge, lbs-oz	6 - 6	9 - 6	9 - 0	10 - 0	9 - 10	14 - 12	13 - 13
Indoor Coil ^{2,3}	Additional Charge, Oz						
FC/MC/PC/UC18	.051 / TXV + 0	-	-	-	-	-	-
FC/MC/PC/UC24	.051 / TXV + 5	-	-	-	-	-	-
FC/MC/PC/UC30	.051 / TXV + 5	-	-	-	-	-	-
FC/MC/PC/UC32	-	.054 / TXV + 0	.063 / TXV + 0	-	-	-	-
FC/MC/PC/UC35	-	.054 / TXV + 0	.063 / TXV + 0	-	-	-	-
FC/MC/PC/UC37	-	.054 / TXV + 5	.063 / TXV + 6	.071 / TXV + 0	-	-	-
FC/MC/PC/UC43	-	.054 / TXV + 5	.063 / TXV + 6	.071 / TXV + 0	-	-	-
FC/MC/PC/UC48	-	-	-	.071 / TXV + 10	.075 / TXV + 0	-	-
FC/MC/PC/UC60	-	-	-	-	.075 / TXV + 8	TXV + 0	-
FC/PC62	-	-	-	-	-	TXV + 5	TXV + 0
FC64	-	-	-	-	-	-	TXV + 8
HD48	-	-	-	.071 / TXV + 13	-	-	-
HD60	-	-	-	-	.075 / TXV + 10	-	-
AHP18	.051 / TXV + 0	-	-	-	-	-	-
AHP24	.051 / TXV + 2	-	-	-	-	-	-
AHP30	-	.054 / TXV + 0	.063 / TXV + 0	-	-	-	-
AHP36	-	-	.063 / TXV + 6	.071 / TXV + 0	-	-	-
AHP42	-	-	-	.071 / TXV + 0	-	-	-
AHP48	-	-	-	-	.075 / TXV + 8	TXV + 0	-
AHP60	-	-	-	-	.075 / TXV + 8	TXV + 0	-
AHX18	.051 / TXV + 0	-	-	-	-	-	-
AHX30	-	.054 / TXV + 0	.063 / TXV + 0	-	-	-	-
AHX36	-	.054 / TXV + 5	.063 / TXV + 6	.071 / TXV + 0	-	-	-
AHX42	-	-	-	.071 / TXV + 10	.075 / TXV + 0	-	-
AHX48	-	-	-	-	.075 / TXV + 8	TXV + 0	-
AHX60	-	-	-	-	-	TXV + 5	TXV + 0
AV24	.051 / TXV + 2	-	-	-	-	-	-
AV36	-	.054 / TXV + 5	.063 / TXV + 6	.071 / TXV + 0	-	-	-
AV48	-	-	-	-	.075 / TXV + 8	TXV + 0	-
AV60	-	-	-	-	.075 / TXV + 8	TXV + 0	-
F4FP024	.051 / TXV + 0	-	-	-	-	-	-
F4FP040	-	.054 / TXV + 0	.063 / TXV + 0	-	-	-	-
F4FP045	-	-	-	.071 / TXV + 14	.075 / TXV + 8	-	-
F4FV060	-	-	-	-	.075 / TXV + 8	TXV + 0	-
F5FP048	-	-	-	.071 / TXV + 12	.075 / TXV + 0	-	-
F5FP060	-	-	-	-	.075 / TXV + 8	TXV + 0	-
F6FP018	.051 / TXV + 0	-	-	-	-	-	-
F6FP024	.051 / TXV + 2	-	-	-	-	-	-
F6FP030	-	.054 / TXV + 0	.063 / TXV + 0	-	-	-	-
F6FP036	-	.054 / TXV + 0	.063 / TXV + 0	-	-	-	-
F6FP042	-	-	-	.071 / TXV + 10	.075 / TXV + 0	-	-
F6FP048	-	-	-	-	.075 / TXV + 8	TXV + 0	-
F6FP060	-	-	-	-	-	TXV + 5	TXV + 0

FOOTNOTES:

1. For applications requiring a TXV use 1TVM series kit.
2. Systems matched with furnace or air handlers not equipped with blower-off delays may require blower Time Delay Kit 2FD06700224.
3. PC coils cannot be used in downflow or horizontal applications. FC coils cannot be used in horizontal applications.

PROCEDURES:

1. Unit factory charge listed on the unit nameplate includes refrigerant for the condenser, the smallest evaporator and 15 feet of interconnecting line tubing.
2. Verify the TXV and additional charge required for specific evaporator coil in the system using the above table.
3. Additional charge for the amount of interconnecting line tubing greater than 15 feet at the rate specified in Physical and Electrical Data Table.
4. For TXV matches requiring additional charge, the refrigerant needs to be weighed in for specific coil match and lineset length.
5. Permanently mark the unit nameplate with the total system charge. Total System Charge = Base Charge (as shipped) + adder for evaporator + adder for line set.

