

# TABULAR DATA SHEET

## Outdoor Split System Heat Pump 2.5 - 5 Tons

**MODELS: THJD30 - 060\***  
**13 SEER – R-410A, 3 PHASE**

### Physical and Electrical Data

MODEL		THJD30 S43S4	THJD36 S43S4	THJD42 S43S4	THJD48 S43S3	THJD60 S43S4	THJD30 S44S4	THJD36 S44S4	THJD42 S44S4	THJD48 S44S3	THJD60 S44S4
Unit Supply Voltage		208-230V, 3 $\phi$ , 60Hz					460V, 3 $\phi$ , 60Hz				
Normal Voltage Range <sup>1</sup>		187 to 252					432 to 532				
Minimum Circuit Ampacity		11.0	12.9	12.9	15.3	22.9	6.0	6.4	7.2	14.2	12.0
Max. Overcurrent Device Amps <sup>2</sup>		15	20	20	25	40	15	15	15	20	20
Min. Overcurrent Device Amps <sup>3</sup>		15	15	15	20	25	15	15	15	15	15
Compressor Type		Recip	Recip	Recip	Recip	Scroll	Recip	Recip	Recip	Recip	Scroll
Compressor Amps	Rated Load	8.1	9.1	9.3	11.2	17.3	4.2	4.5	5.1	10.7	9.0
	Locked Rotor	63	68	68	88	115	30	34	34	60	53
Crankcase Heater		Yes	Yes	Yes	Yes	No	Yes	Yes	Yes	Yes	No
Fan Motor Amps	Rated Load	0.8	1.3	1.3	1.3	1.3	0.8	0.8	0.8	0.8	0.8
	Fan Diameter Inches	24	24	24	24	24	24	24	24	24	24
Fan Motor	Rated HP	1/8	1/4	1/4	1/4	1/4	1/4	1/4	1/4	1/4	1/4
	Nominal RPM	1050	850	850	850	850	850	850	850	850	850
	Nominal CFM	3100	3800	3800	3800	3800	3500	3800	3800	3800	3800
Coil	Face Area Sq. Ft.	21.00	23.58	23.58	23.58	23.58	21.00	23.58	23.58	23.58	23.58
	Rows Deep	1	1	1	1	2	1	1	1	1	2
	Fin / Inches	22	22	22	22	18	22	22	22	22	18
Liquid Line Set OD (Field Installed)		3/8	3/8	3/8	3/8	3/8	3/8	3/8	3/8	3/8	3/8
Vapor Line Set OD (Field Installed)		3/4	3/4	7/8	7/8	7/8	3/4	3/4	7/8	7/8	7/8
Unit Charge (Lbs. - Oz.) <sup>4</sup>		9 - 0	10 - 0	9 - 10	10 - 14	13 - 13	9 - 0	10 - 0	9 - 10	10 - 14	13 - 13
Charge Per Foot, Oz.		0.62	0.62	0.67	0.67	0.67	0.62	0.62	0.67	0.67	0.67
Operating Weight Lbs.		196	208	208	248	280	196	208	208	248	280

1. Rated in accordance with ARI Standard 110, utilization range "A".
2. Dual element fuses or HACR circuit breaker. Maximum allowable overcurrent protection.
3. Dual element fuses or HACR circuit breaker. Minimum recommended overcurrent protection.
4. The Unit Charge is correct for the outdoor unit, matched indoor coil and 15 feet of refrigerant tubing. For tubing lengths other than 15 feet, add or subtract the amount of refrigerant, using the difference in length multiplied by the per foot value. If line exceeds 25 feet, you may refer to publications software 247007 for proper line sizing.

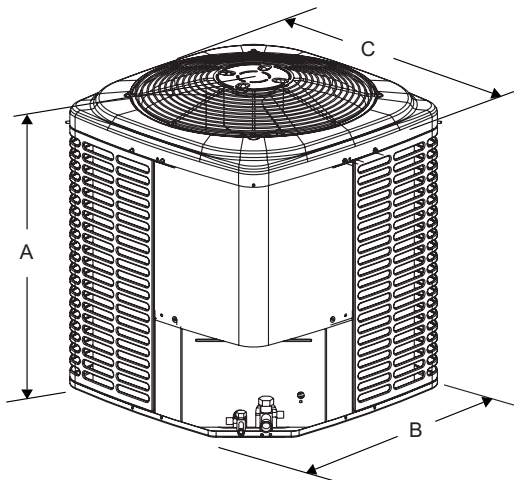

All dimensions are in inches. They are subject to change without notice. Certified dimensions will be provided upon request.

Unit Model	Dimensions (Inches)			Refrigerant Connection Service Valve Size	
	A <sup>1</sup>	B	C	Liquid	Vapor
030	36	34	34	3/8"	3/4"
036	40	34	34		
042	40	34	34		7/8"
048	40	34	34		
060	40	34	34		

1. Including Fan Guard.

### System Charge for Various Matched Systems

Outdoor Unit	THJD30S4(3,4)S4	THJD36S4(3,4)S4	THJD42S4(3,4)S4	THJD48S4(3,4)S3	THJD60S4(3,4)S4
Required Orifice or TXV <sup>1,2</sup>	.063 / 1TVM04G1	.071 / 1TVM04H1	.075 / 1TVM04H1	.078,.081 / 1TVM04K1	1TVM04K1
Factory Charge, lbs-oz	9 - 0	10 - 0	9 - 10	10 - 14	13 - 13
Indoor Coil <sup>3,4</sup>	Additional Charge, Oz				
FC/MC/PC/UC32	.063 / TXV + 0	-	-	-	-
FC/MC/PC/UC35	.063 / TXV + 0	-	-	-	-
FC/MC/PC/UC37	.063 / TXV + 6	.071 / TXV + 0	-	-	-
FC/MC/PC/UC43	.063 / TXV + 6	.071 / TXV + 0	-	-	-
FC/MC/PC/UC48	-	.071 / TXV + 10	.075 / TXV + 0	-	-
FC/MC/PC/UC60	-	-	.075 / TXV + 8	.081 / TXV + 0	-
FC/PC62	-	-	-	-	TXV + 0
FC64	-	-	-	-	TXV + 8
HD48	-	.071 / TXV + 13	-	-	-
HD60	-	-	.075 / TXV + 10	-	-
AHP18	-	-	-	-	-
AHP24	-	-	-	-	-
AHP30	.063 / TXV + 0	-	-	-	-
AHP36	.063 / TXV + 6	.071 / TXV + 0	-	-	-
AHP42	-	.071 / TXV + 0	-	-	-
AHP48	-	-	.075 / TXV + 8	-	-
AHP60	-	-	.075 / TXV + 8	.081 / TXV + 0	-
AHX18	-	-	-	-	-
AHX24	-	-	-	-	-
AHX30	.063 / TXV + 0	-	-	-	-
AHX36	.063 / TXV + 6	.071 / TXV + 0	-	-	-
AHX42	-	.071 / TXV + 10	.075 / TXV + 0	-	-
AHX48	-	-	.075 / TXV + 8	.081 / TXV + 0	-
AHX60	-	-	-	.075 / TXV + 11	TXV + 0
F4FP024	-	-	-	-	-
F4FP040	.063 / TXV + 0	-	-	-	-
F4FP045	-	.071 / TXV + 14	.075 / TXV + 8	-	-
F5FP048	-	.071 / TXV + 12	.075 / TXV + 0	-	-
F5FP060	-	-	.075 / TXV + 8	.081 / TXV + 0	-
F6FP018	-	-	-	-	-
F6FP024	-	-	-	-	-
F6FP030	.063 / TXV + 0	-	-	-	-
F6FP036	.063 / TXV + 0	-	-	-	-
F6FP042	-	.071 / TXV + 10	.075 / TXV + 0	-	-
F6FP048	-	-	.075 / TXV + 8	.081 / TXV + 0	-
F6FP060	-	-	-	.075 / TXV + 11	TXV + 0

**FOOTNOTES:**

- For applications requiring a TXV use 1TVM series kit.
- Approved orifice shipped with outdoor unit.
- Systems matched with furnace or air handlers not equipped with blower-off delays may require blower Time Delay Kit 2FD06700224.
- PC coils cannot be used in downflow or horizontal applications. FC coils cannot be used in horizontal applications.

**PROCEDURES:**

- Unit factory charge listed on the unit nameplate includes refrigerant for the condenser, the smallest evaporator and 15 feet of interconnecting line tubing.
- Verify the TXV and additional charge required for specific evaporator coil in the system using the above table.
- Additional charge for the amount of interconnecting line tubing greater than 15 feet at the rate specified in Physical and Electrical Data Table.
- For TXV matches requiring additional charge, the refrigerant needs to be weighed in for specific coil match and lineset length.
- Permanently mark the unit nameplate with the total system charge. Total System Charge = Base Charge (as shipped) + adder for evaporator + adder for line set.

