

TECHNICAL GUIDE

SPLIT-SYSTEM HEAT PUMPS

13 SEER – R-410A – 3 PHASE

MODELS:

THJD30 THRU 60

(2.5 THRU 5 NOMINAL TONS)



Due to continuous product improvement, specifications are subject to change without notice.

Visit us on the web at www.york.com

Additional rating information can be found at www.aridirectory.org

WARRANTY

Standard 1-year limited parts warranty.
Standard 5-year limited compressor warranty.

DESCRIPTION

The 13 SEER Series unit is the outdoor part of a versatile climate system. It is designed with a matching indoor coil component from Johnson Controls Unitary Products. Available for typical applications this climate system is supported with accessories and documents to serve specific functions.

FEATURES

- **Quality Condenser Coils** - The coil is constructed of copper tubing and enhanced aluminum fins for increased efficiency and corrosion protection.
- **Protected Compressor** - The compressor is internally protected against high pressure, temperature, and externally by a factory installed high pressure switch. This is accomplished by the simultaneous operation of high pressure relief valve and a temperature sensor which protects the compressor if undesirable operating conditions occur. A liquid line filter-drier further protects the compressor.
- **Durable Finish** - The cabinet is made of pre-painted steel. The pre-treated galvanized steel provides a better paint to steel bond, which resists corrosion and rust creep. Special primer formulas and matted-textured finish insure less fading when exposed to sunlight.
- **Lower Installed Cost** - Installation time and costs are reduced by easy power and control wiring connections. Available in sweat connect models only. The unit contains enough refrigerant for matching indoor coils and 15 feet of interconnecting piping. The small base dimension means less space is required on the ground or roof.
- **Top Discharge** - The warm air from the top mounted fan is blown up away from the structure and any landscaping. This allows compact location on multi-unit applications.
- **Low Operating Sound Level** - The upward air flow carries the normal operating noise away from the living area. The rigid top panel effectively isolates any motor sound. Isolator mounted compressor and the rippled fins of the condenser coil muffle the normal fan motor and compressor operating sounds.
- **Low Maintenance** - Long life permanently lubricated motor-bearings need no annual servicing.
- **Easy Service Access** - Fully exposed refrigerant connections, and a single panel covering the electrical controls make for easy servicing of the unit.
- **Secured Service Valves** - Secured re-usable service valves are provided on both the liquid and vapor sweat connections for ease of evacuating and charging.
- **U.L. and C.U.L. Listed** - approved for outdoor application.
- **Agency Listed** - U.L. and C.U.L. listed - approved for outdoor application. The unit is certified in accordance with the Unitary Small Equipment certification program, which is based on ARI Standard 210/240.

Physical and Electrical Data - 3 Phase

MODEL	THJD30 S43S3	THJD36 S43S3	THJD42 S43S3	THJD48 S43S3	THJD60 S43S3	THJD30 S44S3	THJD36 S44S3	THJD42 S44S3	THJD48 S44S3	THJD60 S44S3	
Unit Supply Voltage	208-230V, 3 ϕ , 60Hz					460V, 3 ϕ , 60Hz					
Normal Voltage Range ¹	187 to 252					432 to 532					
Minimum Circuit Ampacity	11.0	12.9	19.1	15.3	23.9	6.0	6.4	8.7	7.2	12.8	
Max. Overcurrent Device Amps ²	15	20	30	25	40	15	15	15	15	20	
Min. Overcurrent Device Amps ³	15	15	20	20	25	15	15	15	15	15	
Compressor Type	Recip	Recip	Scroll	Recip	Scroll	Recip	Recip	Scroll	Recip	Scroll	
Compressor Amps	Rated Load	8.1	9.1	14.1	11.2	17.9	4.2	4.5	6.4	5.1	9.6
	Locked Rotor	63	68	95	88	120	30	34	45	44	70
Crankcase Heater	Yes	Yes	No	No	No	Yes	Yes	No	No	No	
Fan Motor Amps	Rated Load	0.8	1.5	1.5	1.3	1.5	0.8	0.8	0.8	0.8	
	Rated HP	1/8	1/4	1/4	1/4	1/4	1/4	1/4	1/4	1/4	
Fan Motor	Nominal RPM	1050	850	850	850	850	850	850	850	850	
	Nominal CFM	3100	3800	3800	3800	3800	3500	3800	3800	3800	
Coil	Face Area Sq. Ft.	21.00	23.58	23.58	23.58	23.58	21.00	23.58	23.58	23.58	
	Rows Deep	1	1	1	1	2	1	1	1	2	
	Fin / Inches	22	22	22	22	18	22	22	22	18	
Liquid Line Set OD (Field Installed)	3/8	3/8	3/8	3/8	3/8	3/8	3/8	3/8	3/8	3/8	
Vapor Line Set OD (Field Installed)	3/4	3/4	7/8	7/8	7/8	3/4	3/4	7/8	7/8	7/8	
Unit Charge (Lbs. - Oz.) ⁴	9 - 0	9 - 7	9 - 12	10 - 4	13 - 6	9 - 0	9 - 7	9 - 12	10 - 4	13 - 6	
Charge Per Foot, Oz.	0.62	0.62	0.67	0.67	0.67	0.62	0.62	0.67	0.67	0.67	
Operating Weight Lbs.	196	208	208	248	280	196	208	208	248	280	

1. Rated in accordance with ARI Standard 110, utilization range "A".
2. Dual element fuses or HACR circuit breaker. Maximum allowable overcurrent protection.
3. Dual element fuses or HACR circuit breaker. Minimum recommended overcurrent protection.
4. The Unit Charge is correct for the outdoor unit, matched indoor coil and 15 feet of refrigerant tubing. For tubing lengths other than 15 feet, add or subtract the amount of refrigerant, using the difference in length multiplied by the per foot value. If line exceeds 25 feet, you may refer to publications software 036-68001-001 for proper line sizing.

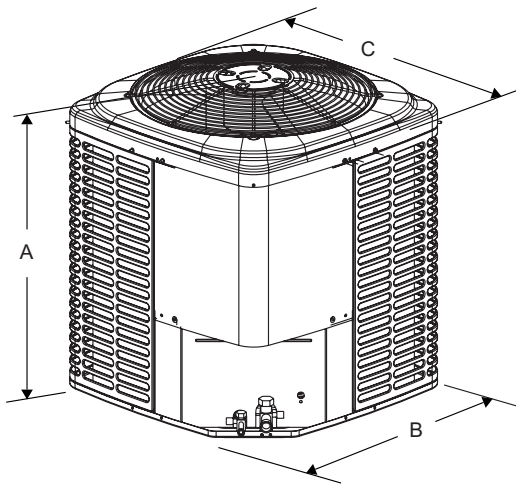

All dimensions are in inches. They are subject to change without notice. Certified dimensions will be provided upon request.

Unit Model	Dimensions (Inches)			Refrigerant Connection Service Valve Size	
	A ¹	B	C	Liquid	Vapor
030	36	34	34	3/8"	3/4"
036	40	34	34		
042	40	34	34		7/8"
048	40	34	34		
060	40	34	34		

1. Including Fan Guard.

System Charge for Various Matched Systems					
Outdoor Unit	THJD30S4(3,4)S3	THJD36S4(3,4)S3	THJD42S4(3,4)S3	THJD48S4(3,4)S3	THJD60S4(3,4)S3
Required Orifice or TXV^{1,2}	.063 / 1TVM04G1	.071 / 1TVM04H1	1TVM04H1	.078, .081 / 1TVM04K1	1TVM04K1
Factory Charge, lbs-oz	9 - 0	9 - 7	9 - 12	10 - 14	13 - 6
Indoor Coil^{3,4}	Additional Charge, Oz				
AHP30	.063 + 0	-	-	-	-
AHP36	.063 + 7	.071 + 0	-	-	-
AHP/SHP48	-	-	0	-	-
AHP/SHP60	-	-	-	081 + 0	-
AHX30	063 + 0	-	-	-	-
AHX36	063 + 7	071 + 0	-	-	-
AHX42	-	071 + 12	0	-	-
AHX48	-	-	0	081 + 0	-
AHX60	-	-	11	075 + 11	0
F5FP048	-	-	0	-	-
F5FP060	-	-	0	081 + 0	-
F6FP030	063 + 0	-	-	-	-
F6FP036	063 + 0	-	-	-	-
F6FP042	-	071 + 12	0	-	-
F6FP048	-	-	0	081 + 0	-
F6FP060	-	-	11	075 + 11	0
FC/MC/PC32A	063 + 0	-	-	-	-
FC/MC/PC35BC	063 + 0	-	-	-	-
FC/MC/PC37A	063 + 7	071 + 0	-	-	-
FC/MC/PC43BC	063 + 7	071 + 0	-	-	-
FC/MC/PC/UC48CD	-	071 + 10	0	-	-
FC/MC/PC/UC60CD	-	-	0	-	-
FC/MC62D	-	-	-	081 + 11	0
HC36B	063 + 0	-	-	-	-
HC42	063 + 7	071 + 0	0	-	-
HC60	-	-	0	-	-
HD48	063 + 8	071 + 8	-	-	-
HD60	-	-	0	-	-

FOOTNOTES:

1. For applications requiring a TXV use 1TVM series kit.
2. Approved orifice shipped with outdoor unit.
3. Systems matched with furnace or air handlers not equipped with blower-off delays may require blower Time Delay Kit 2FD06700224.
4. PC coils cannot be used in downflow or horizontal applications. FC coils cannot be used in horizontal applications.

PROCEDURES:

1. Unit factory charge listed on the unit nameplate includes refrigerant for the condenser, the smallest evaporator and 15 feet of interconnecting line tubing.
2. Verify the TXV and additional charge required for specific evaporator coil in the system using the above table.
3. Additional charge for the amount of interconnecting line tubing greater than 15 feet at the rate specified in Physical and Electrical Data Table.
4. For TXV matches requiring additional charge, the refrigerant needs to be weighed in for specific coil match and lineset length.
5. Permanently mark the unit nameplate with the total system charge. Total System Charge = Base Charge (as shipped) + adder for evaporator + adder for line set.

COOLING CAPACITY - With Air Handler Coils

UNIT MODEL	AIR HANDLER		COIL MODEL ¹	COOLING				
	MODEL	W		RATED CFM	NET MBH		SEER	EER
					TOTAL	SENS.		
13 SEER HP WITH MA								
THJD30S4(3,4)S3	MA12B	17	FC/MC/PC35B	1000	29.0	23.2	13.00	11.00
	MA12B	17	FC/MC/PC43B	1000	29.0	23.4	13.00	11.00
THJD36S4(3,4)S3	MA12B	17	FC/MC/PC43B	1200	35.0	26.8	13.00	11.00
	MA14D	24	FC/MC/PC48D	1200	35.0	27.0	13.00	11.00
THJD42S4(3,4)S3	MA14D	24	FC/MC/PC48D	1400	41.0	31.4	13.00	11.00
	MA16C	21	FC/MC/PC48C	1400	41.0	31.4	13.00	11.00
	MA14D	24	FC/MC/PC60D	1400	41.0	31.2	13.00	11.00
	MA16C	21	FC/MC/PC60C	1400	41.0	31.2	13.00	11.00
THJD60S4(3,4)S3	MA20D	24	MC62D	1800	54.0	42.5	13.00	11.00
13 SEER HP WITH AHP / SHP / F*FP								
THJD30S4(3,4)S3	AHP36	21	—	1000	29.0	23.2	13.00	11.00
	F4FP040	21	—	1000	29.0	22.6	13.00	11.00
THJD36S4(3,4)S3	AHP36	21	—	1200	35.0	26.8	13.00	11.00
	F4FP045	24	—	1200	35.0	26.8	13.00	11.00
THJD42S4(3,4)S3	AHP/SHP48	21	—	1400	41.0	31.4	13.00	11.00
	F4FP045	24	—	1400	41.0	31.2	13.00	11.00
	F5FP048	24	—	1450	41.0	32.6	13.00	11.00
THJD48S4(3,4)S3	AHP/SHP60	24	—	1525	45.0	33.6	13.00	11.00
	F5FP060	24	—	1600	44.5	34.6	13.00	11.00
13 SEER HP WITH AHX / F*FP								
THJD30S4(3,4)S3	AHX30	17	—	1025	28.6	22.4	14.50	12.00
	AHX36	21	—	1005	29.0	22.8	15.00	12.50
	F6FP036	21	—	980	28.4	21.8	14.50	12.50
THJD36S4(3,4)S3	AHX36	21	—	1225	36.0	26.2	14.50	12.50
	AHX42	21	—	1190	36.0	26.2	15.00	12.50
	AHX48	24	—	1255	36.0	26.6	15.00	12.50
	F6FP036	21	—	1210	36.0	25.6	13.50	12.00
	F6FP042	21	—	1290	36.0	26.8	15.00	12.50
	F6FP048	24	—	1125	36.0	25.8	15.00	12.50
THJD42S4(3,4)S3	AHX42	21	—	1395	42.0	31.4	14.00	12.00
	AHX48	24	—	1445	42.0	32.2	14.25	12.00
	AHX60	24	—	1440	42.0	32.2	14.25	12.00
	F6FP042	21	—	1455	41.5	31.8	13.90	12.00
	F6FP048	24	—	1380	42.0	31.6	14.25	12.00
	F6FP060	24	—	1475	42.0	32.4	14.00	12.00
THJD48S4(3,4)S3	AHX48	24	—	1660	45.0	34.8	13.00	11.00
	AHX60	24	—	1570	45.0	34.2	13.00	11.00
	F6FP048	24	—	1625	45.0	34.4	13.00	11.00
	F6FP060	24	—	1570	45.0	34.2	13.00	11.00
THJD60S4(3,4)S3	AHX60	24	—	1905	54.5	43.0	13.10	11.10
	F6FP060	24	—	1710	54.0	41.0	13.50	11.40

Rated in accordance with DOE test procedures (Federal Register 12-27-79 and 3-18-88) and ARI Standards 210.

Cooling MBH based on 80°F entering air temperature, 50% RH, and rated air flow.

EER (Energy Efficiency Ratio) is the total cooling output in BTU's at 95°F outdoor ambient divided by the total electric power in watt-hours at those conditions.

SEER (Seasonal Energy Efficiency Ratio) is the total cooling output in BTU's during a normal annual usage period for cooling divided by the total electric power input in watt-hours during the same period.

1. MC coils available with a factory installed horizontal drain pan. See price pages for specific model number.

— = Not applicable.

COOLING CAPACITY - Upflow, Downflow & Horizontal Furnaces and Coils

UNIT MODEL	FURNACE**		COIL MODEL	COOLING				
	CFM RANGE (Min.-max.)	W		RATED CFM	NET MBH		SEER ¹	EER
					TOTAL	SENS.		
THJD30S4(3,4)S3	800 - 1200	14	FC/MC/PC32	1000	29.0	23.2	13.00	11.00
	800 - 1200	17,21	FC/MC/PC35	1000	29.0	23.2	13.00	11.00
	800 - 1200	14	FC/MC/PC37	1000	29.0	23.4	13.00	11.00
	800 - 1200	17,21	FC/MC/PC43	1000	29.0	23.4	13.00	11.00
	800 - 1200	17	HC36	1000	29.0	23.2	13.00	11.00
	800 - 1200	21	HC42	1000	29.0	23.4	13.00	11.00
	800 - 1200	21,24	HD48	1000	29.0	23.4	13.00	11.00
THJD36S4(3,4)S3	1000 - 1400	14	FC/MC/PC37	1200	35.0	26.6	13.00	11.00
	1000 - 1400	17,21	FC/MC/PC43	1200	35.0	26.8	13.00	11.00
	1000 - 1400	21,24	FC/MC/PC48	1200	35.0	27.0	13.00	11.00
	1000 - 1400	21	HC42	1200	35.0	26.8	13.00	11.00
	1000 - 1400	21,24	HD48	1200	35.0	26.8	13.00	11.00
THJD42S4(3,4)S3	1200 - 1600	21,24	FC/MC/PC48	1400	41.0	31.4	13.00	11.00
	1200 - 1600	21,24	FC/MC/PC60	1400	41.0	31.2	13.00	11.00
	1200 - 1600	21	HC42	1400	41.0	31.2	13.00	11.00
	1200 - 1600	24	HC60	1400	41.0	31.2	13.00	11.00
	1200 - 1600	21,24	HD60	1400	41.0	31.4	13.00	11.00
THJD60S4(3,4)S3	1600 - 2000	21,24	MC62	1800	54.0	42.5	13.00	11.00

1. Requires a 2FD06700224 Blower Time Delay unless a standard furnace is equipped with one.

** Refer to Quick Selection Chart for specific furnace match-up.

COOLING CAPACITY - With High Efficiency Motor Furnaces

MODELS	FURNACE MODEL	COIL MODEL ¹	W	COOLING				
				RATED CFM	Net MBH		SEER	EER
					TOTAL	SENS.		
13 SEER HP WITH VARIABLE SPEED FURNACES²								
THJD30S4(3,4)S3	T*(8,L)X*A12	FC/MC/PC37A	14	1105	30.4	24.4	14.40	12.10
	T*9X*B12	FC/MC/PC43B	17	1095	30.4	24.4	14.45	12.15
	T*(8,L)X*B12	FC/MC/PC43B	17	1125	30.4	24.2	14.40	12.10
THJD36S4(3,4)S3	T*9X*B12	FC/MC/PC43B	17	1270	36.4	27.4	14.00	11.70
	T*(8,L)X*B12	FC/MC/PC43B	17	1300	36.4	27.4	14.05	11.70
	T*(8,L)X*C16	FC/MC/PC43C	21	1175	36.4	27.0	14.70	12.20
	T*9X*C16	FC/MC/PC43C	21	1260	36.4	27.6	14.20	11.80
	T*(8,L)X*C20	FC/MC/PC43C	21	1250	36.6	27.6	14.55	12.20
	T*9X*C20	FC/MC/PC43C	21	1185	36.2	26.8	14.30	12.00
THJD42S4(3,4)S3	T*(8,L)X*C16	FC/MC/PC48C	21	1360	41.5	31.4	13.80	11.75
	T*9X*C16	FC/MC/PC48C	21	1425	41.5	31.8	13.60	11.50
	T*(8,L)X*C20	FC/MC/PC48C	21	1475	42.0	32.6	14.00	11.75
	T*9X*C20	FC/MC/PC48C	21	1420	41.5	32.0	13.60	11.70
	T*9X*D20	FC/MC/PC48D	24	1435	41.5	32.0	13.70	11.75
	T*(8,L)X*C16	UC48C	21	1400	42.0	32.2	13.80	11.90
	T*9X*C16	UC48C	21	1425	42.0	32.0	13.60	11.70
	T*(8,L)X*C20	UC48C	21	1515	42.0	33.2	13.90	11.75
	T*9X*C20	UC48C	21	1420	42.0	32.0	13.50	11.60
	T*9X*D20	UC48D	24	1435	41.5	32.2	13.70	11.75
THJD48S4(3,4)S3	T*9X*D20	FC/MC62D	24	1610	45.0	34.2	13.00	11.00
THJD60S4(3,4)S3	T*(8,L)X*C20	FC/MC62D	21	1665	56.0	41.5	13.80	11.50
	T*9X*D20	FC/MC62D	24	1515	54.5	39.0	13.10	11.00

1. MC coils available with a factory installed horizontal drain pan. See price pages for specific model number.

2. Variable speed furnaces have B.O.D (Blower on Delay) standard.

HEATING PERFORMANCE - With Air Handler

UNIT MODEL*	AIR HANDLER	COIL ¹ MODEL	ARI HEATING ²						
			47°F			17°F			HSPF
			MBH	COP	KW	MBH	COP	KW	STD
13 SEER HP WITH MA									
THJD30S4(3,4)S3	MA12B	FC/MC/PC35B	28.0	3.34	2.46	16.4	2.30	2.09	7.70
	MA12B	FC/MC/PC43B	28.2	3.40	2.43	16.6	2.32	2.10	7.70
THJD36S4(3,4)S3	MA12B	FC/MC/PC43B	35.0	3.42	3.00	21.2	2.36	2.63	8.00
	MA14D	FC/MC/PC48D	35.0	3.42	3.00	21.4	2.36	2.66	8.00
	MA16C	FC/MC43C	35.0	3.48	3.03	21.0	2.40	2.56	8.00
	MA16C	FC/MC48C	35.0	3.48	3.03	21.0	2.40	2.56	8.00
THJD42S4(3,4)S3	MA14D	FC/MC/PC48D	41.0	3.48	3.45	28.0	2.46	3.34	8.00
	MA16C	FC/MC/PC48C	41.0	3.48	3.45	28.0	2.46	3.34	8.00
	MA14D	FC/MC/PC60D	41.0	3.66	3.28	27.8	2.56	3.18	8.00
	MA16C	FC/MC/PC60C	41.0	3.66	3.28	27.8	2.56	3.18	8.00
THJD60S4(3,4)S3	MA20D	MC62D	56.5	3.48	4.76	35.4	2.42	4.29	8.00
13 SEER HP WITH AHP / SHP / F*FP									
THJD30S4(3,4)S3	AHP36	—	28.2	3.40	2.43	16.6	2.32	2.10	7.70
	F4FP040	—	28.0	3.32	2.47	16.4	2.28	2.11	7.70
THJD36S4(3,4)S3	AHP36	—	35.0	3.40	3.02	21.0	2.40	2.56	8.00
	F4FP045	—	35.0	3.40	3.02	21.6	2.42	2.62	8.00
THJD42S4(3,4)S3	AHP/SHP48	—	41.0	3.32	3.62	28.2	2.36	3.50	8.00
	F4FP045	—	41.0	3.68	3.27	27.8	2.56	3.18	8.00
	F5FP048	—	41.0	3.68	3.27	27.6	2.58	3.14	8.00
THJD48S4(3,4)S3	AHP/SHP60	—	45.0	3.80	4.13	26.0	2.72	3.69	8.00
	F5FP060	—	44.0	3.78	4.11	27.0	2.66	3.69	8.00
13 SEER HP WITH AHX / F*FP									
THJD30S4(3,4)S3	AHX30	—	28.2	3.78	2.19	15.6	2.60	1.76	7.80
	AHX36	—	28.2	3.98	2.08	15.4	2.70	1.67	8.00
	F6FP036	—	27.8	3.78	2.16	15.3	2.60	1.72	7.80
THJD36S4(3,4)S3	AHX36	—	36.0	3.86	2.73	19.6	2.62	2.19	8.20
	AHX42	—	35.8	3.88	2.70	19.5	2.66	2.15	8.20
	AHX48	—	36.0	3.94	2.68	19.7	2.66	2.17	8.20
	F6FP036	—	35.6	3.64	2.87	19.4	2.50	2.27	7.90
	F6FP042	—	36.0	3.90	2.71	20.0	2.62	2.24	8.20
	F6FP048	—	36.0	3.96	2.66	19.8	2.68	2.17	8.20
THJD42S4(3,4)S3	AHX42	—	42.0	3.84	3.21	27.2	2.60	3.07	8.20
	AHX48	—	42.0	3.88	3.17	27.0	2.60	3.04	8.20
	AHX60	—	42.0	3.92	3.14	26.6	2.58	3.02	8.20
	F6FP042	—	42.0	3.86	3.19	27.4	2.58	3.11	8.10
	F6FP048	—	42.0	3.98	3.09	27.0	2.66	2.97	8.20
	F6FP060	—	42.0	3.92	3.14	26.8	2.58	3.04	8.20
THJD48S4(3,4)S3	AHX48	—	45.0	3.72	3.82	26.0	2.64	3.63	8.00
	AHX60	—	44.5	3.78	3.84	25.8	2.68	3.68	8.00
	F6FP048	—	45.0	3.80	3.78	26.6	2.68	3.65	8.00
	F6FP060	—	44.5	3.78	3.84	25.8	2.68	3.71	8.00
THJD60S4(3,4)S3	AHX60	—	56.5	3.54	4.68	35.4	2.44	4.25	8.00
	F6FP060	—	56.0	3.52	4.66	34.8	2.46	4.15	8.10

1. Rated CFM same as for cooling.

2. Heating MBH based on ARI standards of 70° DB entering indoor air, 72% RH outdoor air with 25 feet of interconnecting piping and no supplemental electric heat operation.

CP equals MBH output divided by (total KW input x 3.412).

HSPF (Heating Seasonal Performance Factor) is the total heating output during a normal annual usage period for heating divided by the total electric power input during the same period.

— = Not Applicable.

HEATING PERFORMANCE - Upflow, Downflow, and Horizontal Furnaces and Coils

UNIT MODEL*	COIL ¹ MODEL	ARI HEATING ²						
		47°F			17°F			HSPF
		MBH	COP	KW	MBH	COP	KW	STD
THJD30S4(3,4)S3	FC/MC/PC32	28.0	3.34	2.46	16.4	2.28	2.11	7.70
	FC/MC/PC35	28.0	3.34	2.46	16.4	2.30	2.09	7.70
	FC/MC/PC37	28.2	3.40	2.43	16.6	2.32	2.10	7.70
	FC/MC/PC43	28.2	3.40	2.43	16.6	2.32	2.10	7.70
	HC36	28.2	3.34	2.47	16.4	2.28	2.11	7.70
	HC42	28.2	3.40	2.43	16.6	2.32	2.10	7.70
	HD48	28.2	3.60	2.30	16.6	2.32	2.10	7.70
THJD36S4(3,4)S3	FC/MC/PC37	35.0	3.40	3.02	21.2	2.36	2.63	8.00
	FC/MC/PC43	35.0	3.42	3.00	21.2	2.36	2.63	8.00
	FC/MC/PC48	35.0	3.42	3.00	21.4	2.36	2.66	8.00
	HC42	35.0	3.42	3.00	21.2	2.36	2.63	8.00
	HD48	35.0	3.40	3.02	20.0	2.16	2.71	8.00
THJD42S4(3,4)S3	FC/MC/PC48	41.0	3.48	3.45	28.0	2.46	3.34	8.00
	FC/MC/PC60	41.0	3.66	3.28	27.8	2.56	3.18	8.00
	HC42	41.0	3.46	3.47	27.8	2.48	3.29	8.00
	HC60	41.0	3.66	3.28	27.8	2.56	3.18	8.00
	HD60	41.0	3.14	3.83	27.6	2.26	3.58	8.00
THJD60S4(3,4)S3	MC62	56.5	3.48	4.76	35.4	2.42	4.29	8.00

1. Rated CFM same as for cooling.

2. Heating MBH based on ARI standards of 70° DB entering indoor air, 72% RH outdoor air with 25 feet of interconnecting piping and no supplemental electric heat operation.

CP equals MBH output divided by (total KW input x 3.412).

HSPF (Heating Seasonal Performance Factor) is the total heating output during a normal annual usage period for heating divided by the total electric power input during the same period.

— = Not Applicable.

HEATING CAPACITY - With High Efficiency Motor Furnaces

UNIT MODELS	FURNACE MODEL	COIL ¹ MODEL	ARI HEATING ²						
			47°F			17°F			HSPF
			MBH	COP	KW	MBH	COP	KW	STD
13 SEER HP WITH VARIABLE SPEED FURNACES³									
THJD30S4(3,4)S3	T*(8,L)X*A12	FC/MC/PC37A	29.0	3.68	2.30	16.3	2.48	1.93	7.80
	T*9X*B12	FC/MC/PC43B	29.0	3.70	2.30	16.3	2.48	1.93	7.90
	T*(8,L)X*B12	FC/MC/PC43B	29.0	3.68	2.30	16.3	2.48	1.93	7.90
THJD36S4(3,4)S3	T*9X*B12	FC/MC/PC43B	35.0	3.60	2.85	20.8	2.52	2.42	8.20
	T*(8,L)X*B12	FC/MC/PC43B	35.0	3.60	2.85	20.6	2.52	2.40	8.20
	T*(8,L)X*C16	FC/MC/PC43C	34.2	3.66	2.74	20.2	2.58	2.29	8.20
	T*9X*C16	FC/MC/PC43C	35.0	3.62	2.83	20.6	2.54	2.38	8.25
	T*(8,L)X*C20	FC/MC/PC43C	34.8	3.68	2.77	20.4	2.58	2.32	8.30
	T*9X*C20	FC/MC/PC43C	34.6	3.60	2.82	20.4	2.54	2.35	8.20
	T*(8,L)X*D20	FC/MC/PC43D	34.6	3.60	2.82	20.4	2.54	2.35	8.20
THJD42S4(3,4)S3	T*(8,L)X*C16	FC/MC/PC48C	41.0	3.82	3.15	27.6	2.66	3.04	8.20
	T*9X*C16	FC/MC/PC48C	41.5	3.80	3.20	27.8	2.64	3.09	8.10
	T*(8,L)X*C20	FC/MC/PC48C	41.5	3.88	3.13	27.6	2.68	3.02	8.20
	T*9X*C20	FC/MC/PC48C	41.5	3.82	3.18	27.6	2.66	3.04	8.10
	T*9X*D20	FC/MC/PC48D	41.5	3.86	3.15	27.6	2.66	3.04	8.20
	T*(8,L)X*C16	UC48C	41.5	4.00	3.04	27.4	2.74	2.93	8.20
	T*9X*C16	UC48C	41.5	3.90	3.12	27.6	2.68	3.02	8.20
	T*(8,L)X*C20	UC48C	41.5	4.04	3.01	27.4	2.76	2.91	8.20
	T*9X*C20	UC48C	41.5	3.94	3.09	27.6	2.72	2.97	8.20
T*9X*D20	UC48D	41.5	3.98	3.06	27.4	2.74	2.93	8.20	
THJD48S4(3,4)S3	T*9X*D20	FC/MC62D	45.0	3.80	3.93	26.0	2.72	4.15	8.00
THJD60S4(3,4)S3	T*(8,L)X*C20	FC/MC62D	56.5	3.60	4.60	32.6	2.46	3.88	8.10
	T*9X*D20	FC/MC62D	56.5	3.44	4.81	34.0	2.34	4.26	8.00

1. Rated CFM same as for cooling.
 2. Heating MBH based on ARI standards of 70° DB entering indoor air, 72% RH outdoor air with 25 feet of interconnecting piping and no supplemental electric heat operation.
 3. Variable speed furnaces have B.O.D (Blower on Delay) standard.
CP equals MBH output divided by (total KW input x 3.412).
HSPF (Heating Seasonal Performance Factor) is the total heating output during a normal annual usage period for heating divided by the total electric power input during the same period.
- = Not Applicable.

ACCESSORIES

Refer to Price Manual for specific model numbers.

Start Assist Kit (2SA067*) - May be required on 42, 48, 60 models. Models 18, 24, 30, 36 have been factory installed.

Blower Time Delay - Available to increase efficiency when installed. Installs on indoor section and maintains blower for approximately one minute after cooling thermostat has been satisfied.

Hard Start Kits - Provides required starting torque for use with Thermal Expansion Valve Kit.

Low Temperature Cutout (2LT06700224) - Prevents heat pump operation below -10°F ambient temperature.

Compressor Blanket - Designed to further reduce the normal operating sound.

Add-on Fossil Fuel Control - Interface controls for use with gas, oil furnaces and the heat pump system are available.

Thermal Expansion Valve Kit - 1TVM900 Series TXV kit used to improve system performance.

Outdoor Thermostat (2TD06700124) - Provides additional staging of supplemental electric heat.

Thermostats - Compatible thermostat controls are available through accessory sourcing. For optimum performance and installation, refer to the UPGNET "Low Voltage Wiring Diagram" document to select and apply controls.

SOUND POWER RATINGS

UNIT MODEL	(dBA)*			
	230		460	
	Cooling	Heating	Cooling	Heating
030	77.4	77.1	77.4	77.1
036	77.8	78.9	77.8	78.9
042	72.7	75.2	72.7	75.2
048	76.7	78.1	76.7	78.1
060	77.2	78.9	77.2	78.9

* Rated in accordance with ARI 270-95 Standards.

TYPICAL INSTALLATION

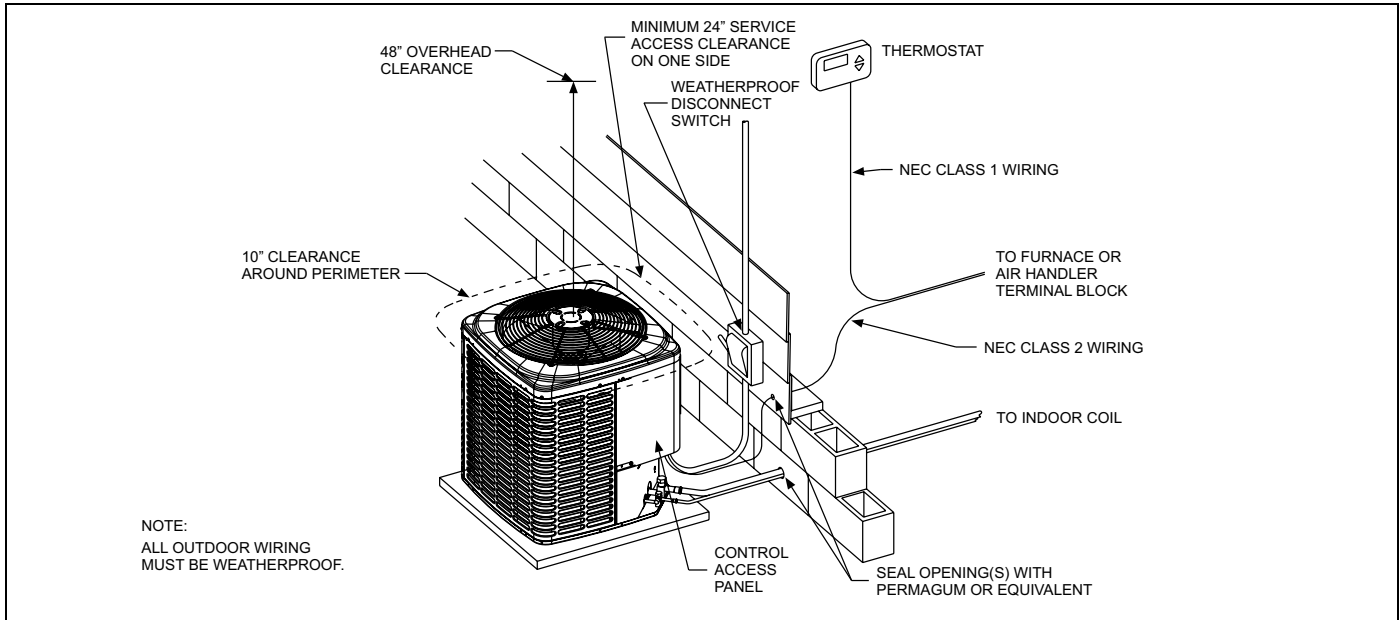

TYPICAL FIELD WIRING

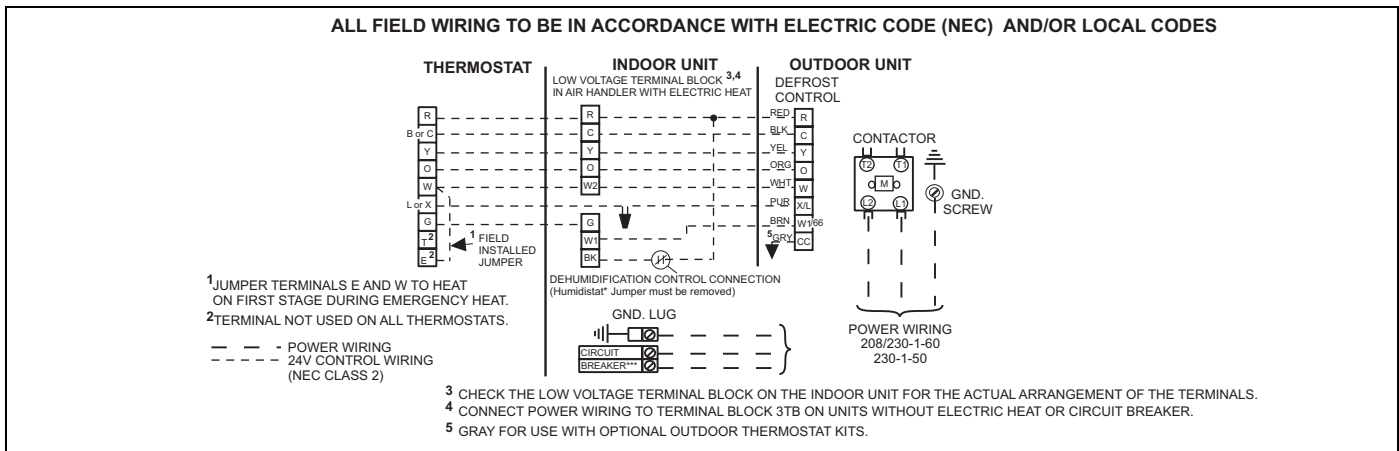

COOLING PERFORMANCE DATA																
CONDENSING UNIT MODEL NO.		THJD30S4(3,4)S3														
INDOOR COIL MODEL NO.		AHP36														
CONDENSING ENTERING AIR TEMPERATURE	IDCFM	800					1000					1200				
	ID DB (°F)	80	80	75	80	80	80	80	75	80	80	80	80	75	80	80
	ID WB (°F)	57	62	62	67	72	57	62	62	67	72	57	62	62	67	72
65	T.C.	28.5	30.9	31.1	34.0	37.0	30.8	32.4	32.4	35.6	38.7	33.1	33.9	33.7	37.2	40.5
	S.C.	28.5	26.1	22.3	22.1	18.6	30.8	29.7	24.5	24.4	19.8	33.1	33.4	26.8	26.7	21.1
	KW	1.7	1.8	1.8	1.8	1.7	1.7	1.8	1.8	1.7	1.7	1.7	1.8	1.8	1.7	1.7
75	T.C.	27.1	29.1	29.1	32.0	35.3	29.2	30.3	30.3	33.4	36.6	31.3	31.5	31.5	34.7	37.9
	S.C.	27.1	25.2	21.4	21.3	17.7	29.2	28.2	23.6	23.5	18.9	31.3	31.3	25.8	25.7	20.1
	KW	1.9	1.9	1.9	1.9	1.9	1.9	1.9	1.9	1.9	1.9	1.9	1.9	1.9	1.9	1.9
85	T.C.	25.7	27.2	27.2	30.0	33.6	27.6	28.2	28.2	31.2	34.5	29.5	29.2	29.2	32.3	35.4
	S.C.	25.7	24.3	20.5	20.4	16.8	27.6	26.7	22.7	22.6	17.9	29.5	29.2	24.8	24.7	19.1
	KW	2.0	2.1	2.1	2.1	2.1	2.1	2.1	2.1	2.1	2.1	2.1	2.1	2.1	2.1	2.1
95	T.C.	24.3	25.3	25.3	28.1	31.8	26.0	26.1	26.1	29.0	32.3	27.7	26.8	27.0	29.9	32.9
	S.C.	24.3	23.4	19.6	19.6	15.9	26.0	25.2	21.7	21.7	17.0	27.7	26.8	23.9	23.7	18.0
	KW	2.2	2.2	2.2	2.3	2.3	2.2	2.2	2.2	2.3	2.3	2.3	2.3	2.3	2.3	2.3
105	T.C.	22.6	23.3	23.0	25.7	29.1	24.1	24.2	23.7	26.4	29.6	25.6	25.1	24.4	27.2	30.1
	S.C.	22.6	22.1	18.6	18.6	14.9	24.1	23.7	20.5	20.7	16.0	25.6	25.1	22.4	22.7	17.1
	KW	2.4	2.4	2.4	2.4	2.5	2.4	2.4	2.4	2.4	2.5	2.4	2.4	2.4	2.5	2.5
115	T.C.	21.0	21.3	20.9	23.4	26.4	22.3	22.3	21.3	24.0	26.9	23.6	23.4	21.8	24.5	27.4
	S.C.	21.0	20.8	17.7	17.7	13.9	22.3	22.2	19.3	19.7	15.0	23.6	23.4	20.9	21.8	16.1
	KW	2.5	2.5	2.5	2.6	2.7	2.6	2.6	2.5	2.6	2.7	2.6	2.6	2.6	2.6	2.7
125	T.C.	19.4	19.3	18.7	21.1	23.7	20.5	20.5	19.0	21.5	24.2	21.6	21.6	19.3	21.9	24.7
	S.C.	19.4	19.3	16.7	16.8	12.9	20.5	20.5	18.1	18.8	14.1	21.6	21.6	19.3	20.8	15.2
	KW	2.7	2.7	2.7	2.8	2.8	2.7	2.7	2.7	2.8	2.9	2.8	2.8	2.7	2.8	2.9

NOTE: ALL CAPACITIES INCLUDE INDOOR FAN HEAT AT 1250 BTUH/1000 CFM.

Multipliers for determining the performance with other indoor sections.

NOTE: For dry bulb temperatures different than those listed (between 73-87 F), sensible capacity increases by 1060 BTUH per 1000 CFM per degree above the listed temperature and decreases by 1060 BTUH per 1000 CFM per degree below the listed temperature.

Air Handler	Coil	T.C.	S.C.	KW
–	FC/MC/PC32	0.99	0.99	1.00
–	FC/MC/PC35	0.99	0.99	1.00
–	FC/MC/PC37	1.01	1.01	1.00
–	FC/MC/PC43	1.01	1.01	1.00
–	HC36	0.99	0.99	1.00
–	HC42	1.01	1.01	1.00
–	HD48	1.01	1.01	1.00
AHP36	–	1.00	1.00	1.00
AHX30	–	0.99	1.06	0.93
AHX36	–	1.00	1.07	0.90
F4FP040	–	0.99	0.97	1.00
F6FP036	–	0.98	1.02	0.91
MA12B	FC/MC/PC35B	0.99	0.99	1.00
MA12B	FC/MC/PC43B	1.01	1.01	1.00

Furnaces	Coils	T.C.	S.C.	KW
T*(8,L)X*A12	FC/MC/PC37A	1.05	1.10	0.95
T*9X*B12	FC/MC/PC43B	1.05	1.10	0.94
T*(8,L)X*B12	FC/MC/PC43B	1.05	1.10	0.95

COOLING PERFORMANCE DATA																
CONDENSING UNIT MODEL NO.		THJD36S4(3,4)S3														
INDOOR COIL MODEL NO.		AHP36														
CONDENSING ENTERING AIR TEMPERATURE	IDCFM	1000					1200					1400				
	ID DB (°F)	80	80	75	80	80	80	80	75	80	80	80	80	75	80	80
	ID WB (°F)	57	62	62	67	72	57	62	62	67	72	57	62	62	67	72
65	T.C.	37.0	40.3	39.8	43.7	47.3	39.3	41.5	41.2	45.3	48.9	41.6	42.6	42.7	46.8	50.5
	S.C.	35.7	32.2	27.3	27.6	23.6	37.9	35.0	29.4	29.4	24.6	40.2	37.8	31.4	31.3	25.6
	KW	2.2	2.2	2.2	2.1	2.2	2.2	2.2	2.2	2.1	2.2	2.1	2.2	2.2	2.2	2.2
75	T.C.	35.3	37.9	37.5	41.4	44.9	37.5	39.0	38.7	42.7	46.3	39.7	40.2	40.0	44.1	47.8
	S.C.	34.1	31.1	26.4	26.5	22.3	36.2	33.9	28.4	28.4	23.4	38.3	36.6	30.4	30.3	24.4
	KW	2.4	2.4	2.4	2.4	2.4	2.4	2.4	2.4	2.4	2.4	2.4	2.4	2.4	2.4	2.4
85	T.C.	33.7	35.4	35.2	39.0	42.4	35.7	36.6	36.2	40.2	43.7	37.7	37.8	37.3	41.4	45.1
	S.C.	32.5	30.1	25.4	25.5	21.1	34.5	32.7	27.4	27.4	22.2	36.4	35.4	29.3	29.2	23.2
	KW	2.6	2.6	2.6	2.6	2.6	2.6	2.6	2.6	2.6	2.6	2.6	2.6	2.6	2.6	2.6
95	T.C.	32.1	33.0	32.9	36.6	39.9	33.9	34.2	33.8	37.7	41.1	35.7	35.4	34.6	38.7	42.4
	S.C.	31.0	29.1	24.4	24.5	19.9	32.7	31.6	26.4	26.4	20.9	34.5	34.2	28.3	28.2	22.0
	KW	2.7	2.8	2.8	2.8	2.8	2.8	2.8	2.8	2.8	2.9	2.8	2.8	2.8	2.8	2.9
105	T.C.	29.9	30.2	30.2	33.6	36.9	31.6	31.6	30.9	34.5	38.0	33.2	32.9	31.6	35.5	39.0
	S.C.	28.9	27.4	23.3	23.3	18.7	30.5	29.6	25.2	25.2	19.7	32.0	31.8	27.1	27.0	20.7
	KW	2.9	3.0	3.0	3.0	3.1	3.0	3.0	3.0	3.0	3.1	3.0	3.0	3.0	3.0	3.1
115	T.C.	27.8	27.6	27.5	30.7	34.0	29.3	29.1	28.1	31.5	34.9	30.8	30.5	28.7	32.3	35.8
	S.C.	26.9	25.7	22.1	22.2	17.5	28.3	27.6	24.0	24.0	18.5	29.7	29.5	25.9	25.9	19.5
	KW	3.1	3.1	3.1	3.2	3.3	3.2	3.2	3.2	3.2	3.3	3.2	3.2	3.2	3.3	3.3
125	T.C.	25.7	25.0	24.8	27.8	31.1	27.0	26.6	25.3	28.4	31.8	28.3	28.1	25.8	29.1	32.6
	S.C.	24.8	24.1	21.0	21.0	16.4	26.1	25.6	22.9	22.9	17.4	27.3	27.2	24.7	24.7	18.4
	KW	3.3	3.3	3.3	3.4	3.5	3.4	3.4	3.3	3.4	3.5	3.4	3.4	3.4	3.5	3.6

NOTE: ALL CAPACITIES INCLUDE INDOOR FAN HEAT AT 1250 BTUH/1000 CFM.

Multipliers for determining the performance with other indoor sections.

NOTE: For dry bulb temperatures different than those listed (between 73-87 F), sensible capacity increases by 1060 BTUH per 1000 CFM per degree above the listed temperature and decreases by 1060 BTUH per 1000 CFM per degree below the listed temperature.

Air Handler	Coil	T.C.	S.C.	KW
–	FC/MC/PC37	1.00	0.99	1.00
–	FC/MC/PC43	0.99	0.99	1.00
–	FC/MC/PC48	1.00	1.00	1.00
–	HC42	0.99	0.99	1.00
–	HD48	1.00	1.00	1.00
–	HD48	0.97	0.96	1.00
AHX36	–	1.04	1.03	0.94
AHX42	–	1.04	1.03	0.93
AHX48	–	1.04	1.05	0.94
F4FP045	–	1.00	1.00	1.00
F6FP036	–	1.04	1.01	0.96
F6FP042	–	1.04	1.05	0.96
F6FP048	–	1.04	1.01	0.93
MA12B	FC/MC/PC43B	0.99	0.99	1.00
MA14D	FC/MC/PC48D	1.00	1.00	1.00

Furnaces	Coils	T.C.	S.C.	KW
T*9X*B12	FC/MC/PC43B	1.04	1.07	0.96
T*(8,L)X*B12	FC/MC/PC43B	1.04	1.07	0.96
T*(8,L)X*C16	FC/MC/PC43C	1.04	1.05	0.92
T*9X*C16	FC/MC/PC43C	1.04	1.08	0.95
T*(8,L)X*C20	FC/MC/PC43C	1.05	1.08	0.94
T*9X*C20	FC/MC/PC43C	1.03	1.05	0.94

COOLING PERFORMANCE DATA																
CONDENSING UNIT MODEL NO.		THJD42S4(3,4)S3														
INDOOR COIL MODEL NO.		FC/MC/PC48														
CONDENSING ENTERING AIR TEMPERATURE	IDCFM	1200					1400					1600				
	ID DB (°F)	80	80	75	80	80	80	80	75	80	80	80	80	75	80	80
	ID WB (°F)	57	62	62	67	72	57	62	62	67	72	57	62	62	67	72
65	T.C.	39.7	42.2	42.3	46.6	50.3	41.4	43.0	43.0	47.1	51.6	43.2	43.9	43.7	47.7	52.9
	S.C.	39.7	37.8	32.1	32.0	25.7	41.4	41.1	34.2	33.9	27.1	43.2	43.9	36.3	35.8	28.4
	KW	2.4	2.4	2.5	2.5	2.4	2.4	2.4	2.5	2.5	2.4	2.5	2.5	2.4	2.5	2.5
75	T.C.	38.3	40.2	40.3	44.3	48.1	39.9	41.0	41.0	44.9	49.1	41.6	41.9	41.7	45.6	50.2
	S.C.	38.3	36.9	31.2	31.0	24.8	39.9	39.9	33.3	33.0	26.1	41.6	41.9	35.4	34.9	27.3
	KW	2.7	2.7	2.7	2.7	2.7	2.7	2.7	2.7	2.7	2.7	2.7	2.7	2.7	2.7	2.7
85	T.C.	36.9	38.2	38.2	41.9	45.8	38.4	39.0	39.0	42.7	46.7	40.0	39.9	39.7	43.5	47.5
	S.C.	36.9	36.0	30.2	30.0	23.9	38.4	38.6	32.3	32.0	25.1	40.0	39.9	34.5	34.1	26.2
	KW	2.9	3.0	3.0	3.0	3.0	3.0	3.0	3.0	3.0	3.0	3.0	3.0	3.0	3.0	3.0
95	T.C.	35.4	36.1	36.2	39.6	43.5	36.9	37.0	36.9	40.5	44.2	38.4	37.9	37.7	41.4	44.9
	S.C.	35.4	35.1	29.2	29.0	23.0	36.9	37.0	31.4	31.1	24.1	38.4	37.9	33.5	33.2	25.1
	KW	3.2	3.2	3.2	3.2	3.3	3.2	3.2	3.2	3.2	3.3	3.2	3.2	3.2	3.3	3.3
105	T.C.	33.2	33.7	33.4	36.7	40.2	34.5	34.6	34.1	37.4	40.8	35.9	35.5	34.8	38.1	41.4
	S.C.	33.2	33.4	28.0	27.8	21.7	34.5	34.6	30.1	29.8	22.8	35.9	35.5	32.3	31.9	23.8
	KW	3.6	3.6	3.6	3.6	3.7	3.6	3.6	3.6	3.6	3.7	3.6	3.6	3.6	3.7	3.7
115	T.C.	31.1	31.3	30.6	33.8	37.1	32.2	32.3	31.3	34.4	37.5	33.4	33.2	32.0	34.9	37.9
	S.C.	31.1	31.3	26.8	26.6	20.4	32.2	32.3	28.9	28.6	21.5	33.4	33.2	31.0	30.6	22.6
	KW	4.0	4.0	4.0	4.0	4.1	4.0	4.0	4.0	4.0	4.1	4.0	4.0	4.0	4.0	4.1
125	T.C.	28.9	28.9	27.9	31.0	33.9	29.9	29.9	28.5	31.4	34.2	30.9	30.9	29.2	31.7	34.5
	S.C.	28.9	28.9	25.5	25.4	19.1	29.9	29.9	27.7	27.4	20.2	30.9	30.9	29.2	29.4	21.3
	KW	4.5	4.4	4.4	4.4	4.5	4.4	4.4	4.4	4.4	4.5	4.4	4.4	4.4	4.4	4.5

NOTE: ALL CAPACITIES INCLUDE INDOOR FAN HEAT AT 1250 BTUH/1000 CFM.

Multipliers for determining the performance with other indoor sections.

NOTE: For dry bulb temperatures different than those listed (between 73-87 F), sensible capacity increases by 1060 BTUH per 1000 CFM per degree above the listed temperature and decreases by 1060 BTUH per 1000 CFM per degree below the listed temperature.

Air Handler	Coil	T.C.	S.C.	KW
–	FC/MC/PC60	0.99	0.99	1.00
–	HC42	1.00	0.99	1.00
–	HC60	0.99	0.99	1.00
–	HD60	1.01	1.00	1.00
AHP/SHP48	–	1.00	1.00	1.00
AHX42	–	1.03	1.06	0.92
AHX48	–	1.03	1.09	0.92
AHX60	–	1.03	1.09	0.93
F4FP045	–	0.99	1.00	1.00
F5FP048	–	1.02	1.04	1.00
F6FP042	–	1.02	1.08	0.95
F6FP048	–	1.03	1.07	0.93
F6FP060	–	1.03	1.10	0.94
MA14D	FC/MC/PC48D	1.00	1.00	1.00
MA16C	FC/MC/PC48C	1.00	1.00	1.00
MA14D	FC/MC/PC60D	0.99	0.99	1.00
MA16C	FC/MC/PC60C	0.99	0.99	1.00

Furnaces	Coils	T.C.	S.C.	KW
T*(8,L)X*C16	FC/MC/PC48C	1.00	1.05	0.95
T*9X*C16	FC/MC/PC48C	1.01	1.07	0.97
T*(8,L)X*C20	FC/MC/PC48C	1.02	1.09	0.96
T*9X*C20	FC/MC/PC48C	1.01	1.07	0.96
T*9X*D20	FC/MC/PC48D	1.01	1.07	0.96
T*(8,L)X*C16	UC48C	1.02	1.08	0.94
T*9X*C16	UC48C	1.01	1.07	0.97
T*(8,L)X*C20	UC48C	1.02	1.11	0.96
T*9X*C20	UC48C	1.02	1.07	0.96
T*9X*D20	UC48D	1.01	1.08	0.96

COOLING PERFORMANCE DATA																	
CONDENSING UNIT MODEL NO.		THJD48S4(3,4)S3															
INDOOR COIL MODEL NO.		AHP/SHP60															
CONDENSING ENTERING AIR TEMPERATURE	IDCFM	1400					1600					1800					
	ID DB (°F)	80	80	75	80	80	80	80	75	80	80	80	80	75	80	80	
	ID WB (°F)	57	62	62	67	72	57	62	62	67	72	57	62	62	67	72	
65	T.C.	46.3	49.0	49.0	53.3	57.3	48.3	49.9	49.7	54.0	58.4	50.2	50.8	50.4	54.8	59.4	
	S.C.	46.3	43.0	36.2	35.8	29.6	48.3	45.5	37.9	37.6	30.7	50.2	48.0	39.6	39.4	31.8	
	KW	2.5	2.5	2.5	2.5	2.5	2.5	2.5	2.5	2.5	2.5	2.5	2.5	2.5	2.5	2.5	
75	T.C.	44.6	46.6	46.6	50.7	54.8	46.3	47.5	47.3	51.6	55.7	47.9	48.4	48.0	52.4	56.7	
	S.C.	44.6	41.9	35.2	34.8	28.3	46.3	44.4	37.0	36.6	29.4	47.9	46.9	38.8	38.4	30.5	
	KW	2.9	2.8	2.8	2.9	2.9	2.9	2.8	2.8	2.9	2.9	2.8	2.8	2.8	2.9	2.9	
85	T.C.	42.9	44.1	44.2	48.2	52.2	44.3	45.0	44.9	49.1	53.1	45.7	45.9	45.7	50.0	54.0	
	S.C.	42.9	40.9	34.3	33.8	27.1	44.3	43.3	36.1	35.7	28.1	45.7	45.7	38.0	37.5	29.1	
	KW	3.2	3.2	3.2	3.2	3.2	3.2	3.2	3.2	3.2	3.2	3.2	3.2	3.2	3.2	3.2	
95	T.C.	41.1	41.7	41.7	45.7	49.7	42.3	42.6	42.5	46.6	50.5	43.4	43.5	43.3	47.5	51.3	
	S.C.	41.1	39.8	33.3	32.8	25.8	42.3	42.2	35.2	34.7	26.8	43.4	43.5	37.2	36.6	27.8	
	KW	3.5	3.5	3.5	3.6	3.6	3.5	3.5	3.5	3.6	3.6	3.5	3.5	3.5	3.6	3.6	
105	T.C.	38.8	38.7	38.7	42.4	46.4	39.8	39.8	39.4	43.2	47.0	40.9	40.8	40.0	43.9	47.6	
	S.C.	38.8	37.7	32.0	31.6	24.6	39.8	39.7	33.9	33.5	25.6	40.9	40.8	35.9	35.3	26.6	
	KW	4.0	4.0	4.0	4.0	4.0	4.0	4.0	4.0	4.0	4.0	4.0	4.0	4.0	4.0	4.0	
115	T.C.	36.4	35.9	35.9	39.3	43.3	37.5	37.0	36.3	39.8	43.7	38.5	38.1	36.8	40.4	44.1	
	S.C.	36.4	35.7	30.7	30.4	23.4	37.5	37.0	32.7	32.2	24.3	38.5	38.1	34.6	34.1	25.3	
	KW	4.4	4.4	4.4	4.4	4.5	4.4	4.4	4.4	4.4	4.5	4.4	4.4	4.4	4.4	4.5	
125	T.C.	34.1	33.0	33.0	36.1	40.1	35.1	34.2	33.3	36.5	40.4	36.0	35.4	33.6	36.9	40.6	
	S.C.	34.1	33.0	29.5	29.2	22.1	35.1	34.2	31.4	31.0	23.1	36.0	35.4	33.3	32.9	24.1	
	KW	4.8	4.8	4.8	4.8	4.9	4.8	4.8	4.8	4.9	4.9	4.8	4.8	4.8	4.9	4.9	

NOTE: ALL CAPACITIES INCLUDE INDOOR FAN HEAT AT 1250 BTUH/1000 CFM.

Multipliers for determining the performance with other indoor sections.

NOTE: For dry bulb temperatures different than those listed (between 73-87 F), sensible capacity increases by 1060 BTUH per 1000 CFM per degree above the listed temperature and decreases by 1060 BTUH per 1000 CFM per degree below the listed temperature.

Air Handler	Coil	T.C.	S.C.	KW
AHX48	–	1.00	1.04	1.01
AHX60	–	1.00	1.02	1.01
F5FP060	–	0.99	1.03	1.00
F6FP048	–	1.00	1.02	1.01
F6FP060	–	1.00	1.02	1.01

Furnaces	Coils	T.C.	S.C.	KW
T*9X*D20	FC/MC62D	1.00	1.00	1.00

COOLING PERFORMANCE DATA																
CONDENSING UNIT MODEL NO.		THJD60S4(3,4)S3														
INDOOR COIL MODEL NO.		FC/MC62														
CONDENSING ENTERING AIR TEMPERATURE	IDCFM	1600					1800					2000				
	ID DB (°F)	80	80	75	80	80	80	80	75	80	80	80	80	75	80	80
	ID WB (°F)	57	62	62	67	72	57	62	62	67	72	57	62	62	67	72
65	T.C.	54.0	57.1	56.9	62.3	67.6	56.0	57.9	57.8	63.4	69.1	58.0	58.7	58.7	64.4	70.5
	S.C.	54.0	51.0	43.4	42.9	34.8	56.0	54.4	45.4	45.0	36.2	58.0	57.7	47.4	47.1	37.6
	KW	2.8	2.8	2.8	2.9	2.9	2.8	2.8	2.8	2.9	2.9	2.8	2.8	2.8	2.9	2.9
75	T.C.	51.9	54.1	53.9	59.2	64.5	53.7	54.9	54.8	60.2	65.7	55.5	55.7	55.6	61.2	66.9
	S.C.	51.9	49.8	42.0	41.7	33.5	53.7	52.7	44.1	43.8	34.8	55.5	55.6	46.1	45.8	36.2
	KW	3.2	3.2	3.2	3.3	3.3	3.2	3.2	3.2	3.3	3.3	3.2	3.2	3.2	3.3	3.3
85	T.C.	49.7	51.1	51.0	56.2	61.4	51.3	51.9	51.8	57.1	62.4	53.0	52.7	52.6	58.0	63.4
	S.C.	49.7	48.6	40.7	40.5	32.2	51.3	51.1	42.8	42.5	33.4	53.0	52.7	44.9	44.6	34.7
	KW	3.6	3.6	3.6	3.6	3.7	3.6	3.6	3.6	3.7	3.7	3.6	3.6	3.6	3.7	3.7
95	T.C.	47.6	48.1	48.1	53.1	58.3	49.0	48.9	48.8	54.0	59.0	50.4	49.7	49.5	54.8	59.8
	S.C.	47.6	47.4	39.3	39.2	30.9	49.0	48.9	41.5	41.3	32.0	50.4	49.7	43.6	43.3	33.2
	KW	4.0	4.0	4.0	4.0	4.1	4.0	4.0	4.0	4.1	4.1	4.0	4.0	4.0	4.1	4.1
105	T.C.	44.3	44.6	44.1	48.7	53.5	45.6	45.5	44.6	49.3	54.1	46.8	46.3	45.2	50.0	54.7
	S.C.	44.3	44.6	37.6	37.4	29.0	45.6	45.5	39.7	39.4	30.2	46.8	46.3	41.8	41.5	31.3
	KW	4.5	4.5	4.5	4.5	4.6	4.5	4.5	4.5	4.5	4.6	4.5	4.5	4.5	4.5	4.6
115	T.C.	41.1	41.3	40.2	44.4	48.9	42.2	42.2	40.6	44.9	49.4	43.3	43.1	41.0	45.3	49.9
	S.C.	41.1	41.3	35.9	35.7	27.3	42.2	42.2	37.9	37.7	28.4	43.3	43.1	40.0	39.7	29.5
	KW	4.9	5.0	4.9	5.0	5.0	5.0	5.0	4.9	5.0	5.0	5.0	5.0	5.0	5.0	5.0
125	T.C.	37.9	37.9	36.2	40.1	44.3	38.8	38.8	36.5	40.4	44.6	39.8	39.8	36.8	40.7	45.0
	S.C.	37.9	37.9	34.2	33.9	25.5	38.8	38.8	36.2	35.9	26.6	39.8	39.8	36.8	37.9	27.7
	KW	5.4	5.4	5.4	5.4	5.5	5.4	5.4	5.4	5.4	5.5	5.4	5.4	5.4	5.4	5.5

NOTE: ALL CAPACITIES INCLUDE INDOOR FAN HEAT AT 1250 BTUH/1000 CFM.

Multipliers for determining the performance with other indoor sections.

NOTE: For dry bulb temperatures different than those listed (between 73-87 F), sensible capacity increases by 1060 BTUH per 1000 CFM per degree above the listed temperature and decreases by 1060 BTUH per 1000 CFM per degree below the listed temperature.

Air Handler	Coil	T.C.	S.C.	KW	Furnaces	Coils	T.C.	S.C.	KW
AHX60	–	1.02	1.11	0.95	T*(8,L)*C20	FC/MC62D	1.05	1.08	0.99
F6FP060	–	1.01	1.07	0.91	T*9X*D20	FC/MC62D	1.02	1.02	1.02
MA20D	MC62D	1.00	1.00	1.00					

HEATING PERFORMANCE DATA										
CONDENSING UNIT MODEL NO		THJD30S4(3,4)S3								
EVAPORATOR COIL MODEL NO		AHP36								
AIR TEMP. ENTERING OUTDOOR UNIT	AIR TEMP. ENTERING INDOOR COIL	ID CFM								
		800			1000			1200		
		MBTUH	KW	C.O.P.	MBTUH	KW	C.O.P.	MBTUH	KW	C.O.P.
60	60	33.0	2.5	3.9	35.7	2.4	4.3	38.5	2.4	4.7
	70	31.4	2.6	3.6	34.1	2.6	3.9	36.9	2.6	4.2
	80	29.8	2.7	3.2	32.5	2.7	3.5	35.2	2.7	3.8
47	60	28.8	2.3	3.6	30.6	2.3	3.9	32.3	2.3	4.1
	70	26.6	2.4	3.2	28.3	2.4	3.4	29.9	2.4	3.6
	80	24.4	2.5	2.9	26.0	2.5	3.0	27.6	2.5	3.2
40	60	25.8	2.2	3.4	27.1	2.3	3.5	28.4	2.3	3.7
	70	24.2	2.3	3.0	25.4	2.3	3.2	26.6	2.4	3.3
	80	22.6	2.4	2.7	23.7	2.4	2.8	24.7	2.5	2.9
30	60	19.3	2.3	2.5	19.9	2.3	2.5	20.4	2.4	2.5
	70	20.8	2.2	2.7	21.5	2.3	2.8	22.2	2.3	2.9
	80	22.3	2.2	3.0	23.1	2.2	3.1	24.0	2.2	3.2
17	60	13.3	2.1	1.9	14.8	2.1	2.0	16.3	2.2	2.2
	70	15.4	2.1	2.2	16.5	2.1	2.3	17.7	2.1	2.4
	80	17.4	2.0	2.5	18.2	2.1	2.6	19.0	2.1	2.7
10	60	13.0	2.0	1.9	10.0	2.1	1.4	6.9	2.1	1.0
	70	14.5	2.0	2.1	13.4	2.0	1.9	12.2	2.1	1.7
	80	16.0	2.0	2.4	16.7	2.0	2.5	17.5	2.0	2.5

NOTE: ALL CAPACITIES ARE NET (KBTUH) WITH INDOOR FAN HEAT ALREADY DEDUCTED AT 1250 BTUH/1000 CFM.

Multipliers for determining the performance with other indoor sections.

Air Handler	Coil	MBH	KW	COP
–	FC/MC/PC32	0.99	0.98	1.01
–	FC/MC/PC35	0.99	0.98	1.01
–	FC/MC/PC37	1.00	1.00	1.00
–	FC/MC/PC43	1.00	1.00	1.00
–	HC36	0.99	0.98	1.01
–	HC42	1.00	1.00	1.00
–	HD48	1.34	1.40	0.96
AHP36	–	1.00	1.00	1.00
AHX30	–	0.99	1.05	0.94
AHX36	–	0.99	1.10	0.89
F4FP040	–	0.99	0.98	1.02
F6FP036	–	0.97	1.05	0.93
MA12B	FC/MC/PC35B	0.99	0.98	1.01
MA12B	FC/MC/PC43B	1.00	1.00	1.00

Furnaces	Coils	MBH	KW	COP
T*(8,L)X*A12	FC/MC/PC37A	1.00	1.08	0.92
T*9X*B12	FC/MC/PC43B	1.00	1.09	0.92
T*(8,L)X*B12	FC/MC/PC43B	1.00	1.08	0.93

HEATING PERFORMANCE DATA										
CONDENSING UNIT MODEL NO		THJD36S4(3,4)S3								
EVAPORATOR COIL MODEL NO		AHP36								
AIR TEMP. ENTERING OUTDOOR UNIT	AIR TEMP. ENTERING INDOOR COIL	ID CFM								
		1000			1200			1400		
		MBTUH	KW	C.O.P.	MBTUH	KW	C.O.P.	MBTUH	KW	C.O.P.
60	60	44.9	3.1	4.2	46.3	3.2	4.3	47.8	3.2	4.4
	70	42.7	3.3	3.8	44.3	3.3	3.9	45.8	3.4	4.0
	80	40.6	3.4	3.5	42.2	3.5	3.6	43.9	3.5	3.6
47	60	36.8	2.9	3.7	38.6	3.0	3.8	40.5	3.0	3.9
	70	28.4	2.8	3.0	33.4	3.0	3.3	38.5	3.2	3.5
	80	19.9	2.7	2.2	28.2	3.0	2.7	36.5	3.3	3.2
40	60	34.6	2.8	3.6	35.2	2.9	3.6	35.8	3.0	3.5
	70	24.0	3.0	2.4	32.5	3.0	3.2	41.1	3.1	3.9
	80	13.3	3.1	1.3	29.8	3.1	2.8	46.3	3.2	4.3
30	60	28.1	2.7	3.1	29.7	2.8	3.2	31.3	2.8	3.2
	70	25.2	2.8	2.7	27.3	2.9	2.8	29.4	2.9	2.9
	80	22.4	2.9	2.3	24.9	3.0	2.5	27.5	3.0	2.7
17	60	22.2	2.4	2.7	23.1	2.5	2.7	24.0	2.7	2.6
	70	21.0	2.5	2.5	21.6	2.6	2.4	22.2	2.7	2.4
	80	19.8	2.6	2.3	20.1	2.7	2.2	20.3	2.8	2.2
10	60	19.7	2.4	2.4	20.7	2.5	2.5	21.8	2.6	2.5
	70	15.0	2.4	1.8	17.5	2.5	2.1	20.1	2.6	2.2
	80	10.3	2.4	1.3	14.4	2.5	1.7	18.4	2.7	2.0

NOTE: ALL CAPACITIES ARE NET (KBTUH) WITH INDOOR FAN HEAT ALREADY DEDUCTED AT 1250 BTUH/1000 CFM.

Multipliers for determining the performance with other indoor sections.

Air Handler	Coil	MBH	KW	COP
–	FC/MC/PC37	1.01	1.01	1.00
–	FC/MC/PC43	1.01	1.01	1.00
–	FC/MC/PC48	1.01	1.01	1.00
–	HC42	1.01	1.01	1.00
–	HD48	0.96	0.91	1.06
–	HD48	0.96	0.90	1.07
AHX36	–	0.98	1.06	0.92
AHX42	–	0.97	1.07	0.91
AHX48	–	0.99	1.09	0.91
F4FP045	–	1.03	1.06	0.97
F6FP036	–	0.97	1.01	0.96
F6FP042	–	1.00	1.08	0.93
F6FP048	–	0.99	1.09	0.90
MA12B	FC/MC/PC43B	1.01	1.01	1.00
MA14D	FC/MC/PC48D	1.01	1.01	1.00

Furnaces	Coils	MBH	KW	COP
T*9X*B12	FC/MC/PC43B	1.00	1.06	0.95
T*(8,L)X*B12	FC/MC/PC43B	1.00	1.06	0.94
T*(8,L)X*C16	FC/MC/PC43C	0.98	1.07	0.91
T*9X*C16	FC/MC/PC43C	1.00	1.07	0.94
T*(8,L)X*C20	FC/MC/PC43C	0.99	1.08	0.92
T*9X*C20	FC/MC/PC43C	0.99	1.06	0.93

HEATING PERFORMANCE DATA										
CONDENSING UNIT MODEL NO		THJD42S4(3,4)S3								
EVAPORATOR COIL MODEL NO		FC/MC/PC/UC48								
AIR TEMP. ENTERING OUTDOOR UNIT	AIR TEMP. ENTERING INDOOR COIL	ID CFM								
		1200			1400			1600		
		MBTUH	KW	C.O.P.	MBTUH	KW	C.O.P.	MBTUH	KW	C.O.P.
60	60	48.7	3.5	4.1	48.7	3.5	4.1	48.7	3.4	4.2
	70	47.8	3.8	3.6	48.6	3.8	3.7	49.5	3.8	3.8
	80	46.8	4.2	3.3	48.6	4.2	3.4	50.3	4.1	3.6
47	60	42.5	3.3	3.8	42.9	3.3	3.8	43.3	3.2	3.9
	70	42.3	3.6	3.4	42.7	3.6	3.5	43.1	3.6	3.6
	80	42.0	3.9	3.1	42.4	3.9	3.2	42.9	3.9	3.3
40	60	40.1	3.2	3.7	40.5	3.2	3.7	40.8	3.2	3.8
	70	39.1	3.5	3.3	39.6	3.5	3.3	40.0	3.5	3.4
	80	38.2	3.8	2.9	38.7	3.8	3.0	39.2	3.8	3.0
30	60	33.5	3.8	2.6	33.8	3.7	2.7	34.1	3.7	2.7
	70	34.8	3.4	3.0	34.5	3.4	3.0	34.1	3.4	2.9
	80	36.2	3.1	3.4	35.1	3.1	3.3	34.1	3.1	3.2
17	60	27.8	3.6	2.2	28.4	3.6	2.3	29.1	3.6	2.4
	70	28.3	3.3	2.5	28.8	3.3	2.5	29.2	3.3	2.6
	80	28.8	3.0	2.8	29.1	3.0	2.8	29.4	3.0	2.8
10	60	26.3	3.6	2.1	26.9	3.6	2.2	27.6	3.6	2.2
	70	25.6	3.3	2.3	26.8	3.3	2.4	28.0	3.3	2.5
	80	24.8	3.0	2.4	26.6	3.0	2.6	28.4	3.0	2.8

NOTE: ALL CAPACITIES ARE NET (KBTUH) WITH INDOOR FAN HEAT ALREADY DEDUCTED AT 1250 BTUH/1000 CFM.

Multipliers for determining the performance with other indoor sections.

Air Handler	Coil	MBH	KW	COP
-	FC/MC/PC60	1.00	1.06	0.94
-	HC42	0.99	0.99	1.00
-	HC60	1.00	1.06	0.94
-	HD60	0.99	0.89	1.11
AHP/SHP48	-	1.00	1.00	1.00
AHX42	-	0.98	1.06	0.93
AHX48	-	0.98	1.07	0.92
AHX60	-	0.99	1.08	0.92
F4FP045	-	1.01	1.07	0.94
F5FP048	-	0.99	1.01	0.98
F6FP042	-	0.99	1.06	0.93
F6FP048	-	0.99	1.10	0.90
F6FP060	-	0.99	1.08	0.92
MA14D	FC/MC/PC48D	1.00	1.00	1.00
MA16C	FC/MC/PC48C	1.00	1.00	1.00
MA14D	FC/MC/PC60D	1.00	1.06	0.94
MA16C	FC/MC/PC60C	1.00	1.06	0.94

Furnaces	Coils	MBH	KW	COP
T*(8,L)X*C16	FC/MC/PC48C	0.98	1.05	0.94
T*9X*C16	FC/MC/PC48C	0.99	1.04	0.95
T*(8,L)X*C20	FC/MC/PC48C	0.98	1.06	0.93
T*9X*C20	FC/MC/PC48C	0.98	1.05	0.94
T*9X*D20	FC/MC/PC48D	0.98	1.05	0.93
T*(8,L)X*C16	UC48C	0.98	1.09	0.90
T*9X*C16	UC48C	0.99	1.07	0.93
T*(8,L)X*C20	UC48C	0.99	1.10	0.90
T*9X*C20	UC48C	0.99	1.08	0.92
T*9X*D20	UC48D	0.99	1.09	0.91

HEATING PERFORMANCE DATA										
CONDENSING UNIT MODEL NO		THJD48S4(3,4)S3								
EVAPORATOR COIL MODEL NO		AHP/SHP60								
AIR TEMP. ENTERING OUTDOOR UNIT	AIR TEMP. ENTERING INDOOR COIL	ID CFM								
		1400			1600			1800		
		MBTUH	KW	C.O.P.	MBTUH	KW	C.O.P.	MBTUH	KW	C.O.P.
60	60	60.1	4.0	4.4	61.4	4.0	4.5	62.7	3.9	4.7
	70	59.0	4.1	4.3	59.2	4.3	4.0	61.1	4.3	4.2
	80	57.9	4.1	4.1	57.0	4.7	3.6	59.5	4.7	3.7
47	60	52.1	3.3	4.7	51.4	3.7	4.0	48.1	3.7	3.8
	70	51.3	3.6	4.2	50.7	4.2	3.6	49.4	4.1	3.5
	80	50.4	3.9	3.8	50.0	4.6	3.2	50.8	4.6	3.2
40	60	47.4	3.2	4.4	45.5	3.7	3.6	48.5	3.7	3.8
	70	46.9	3.5	3.9	45.5	4.1	3.2	47.1	4.1	3.4
	80	46.5	3.9	3.5	45.5	4.5	3.0	45.7	4.5	3.0
30	60	41.8	3.0	4.0	38.4	4.3	2.6	37.3	4.2	2.6
	70	41.5	3.4	3.6	37.5	3.9	2.9	37.9	3.9	2.9
	80	41.3	3.7	3.3	36.6	3.4	3.1	38.4	3.5	3.2
17	60	35.1	2.9	3.6	28.6	3.9	2.2	29.5	4.0	2.2
	70	35.0	3.2	3.2	29.1	3.6	2.4	29.9	3.6	2.4
	80	34.9	3.5	2.9	29.5	3.3	2.6	30.2	3.3	2.7
10	60	32.0	2.8	3.4	25.8	3.9	2.0	26.4	3.9	2.0
	70	31.8	3.1	3.0	26.4	3.6	2.2	27.3	3.6	2.2
	80	31.7	3.4	2.8	27.0	3.3	2.4	28.1	3.4	2.5

NOTE: ALL CAPACITIES ARE NET (KBTUH) WITH INDOOR FAN HEAT ALREADY DEDUCTED AT 1250 BTUH/1000 CFM.

Multipliers for determining the performance with other indoor sections.

Air Handler	Coil	MBH	KW	COP
AHX48	-	1.00	0.98	1.02
AHX60	-	0.99	0.99	0.99
F5FP060	-	1.00	0.99	1.01
F6FP048	-	1.00	1.00	1.01
F6FP060	-	0.99	0.99	0.99

Furnaces	Coils	MBH	KW	COP
T*9X*D20	FC/MC62D	1.00	1.00	1.00

HEATING PERFORMANCE DATA										
CONDENSING UNIT MODEL NO		THJD60S4(3,4)S3								
EVAPORATOR COIL MODEL NO		FC/MC62								
AIR TEMP. ENTERING OUTDOOR UNIT	AIR TEMP. ENTERING INDOOR COIL	ID CFM								
		1600			1800			2000		
		MBTUH	KW	C.O.P.	MBTUH	KW	C.O.P.	MBTUH	KW	C.O.P.
60	60	65.7	4.7	4.1	66.7	4.6	4.2	67.6	4.6	4.3
	70	64.7	5.1	3.7	65.4	5.0	3.8	66.1	4.9	3.9
	80	63.8	5.5	3.4	64.1	5.4	3.5	64.5	5.3	3.6
47	60	56.9	4.4	3.8	57.4	4.4	3.9	58.0	4.3	4.0
	70	55.8	4.8	3.4	56.3	4.8	3.5	56.8	4.7	3.5
	80	54.7	5.2	3.1	55.2	5.2	3.1	55.6	5.1	3.2
40	60	51.9	4.3	3.5	51.7	4.3	3.5	51.4	4.3	3.5
	70	50.6	4.8	3.1	51.1	4.7	3.2	51.7	4.7	3.2
	80	49.3	5.2	2.8	50.6	5.1	2.9	51.9	5.0	3.0
30	60	44.1	5.0	2.6	43.6	5.0	2.5	43.1	5.0	2.5
	70	45.3	4.6	2.9	44.8	4.6	2.9	44.4	4.6	2.8
	80	46.5	4.2	3.2	46.1	4.2	3.2	45.6	4.1	3.2
17	60	36.6	5.0	2.2	36.8	4.9	2.2	36.9	4.9	2.2
	70	36.0	4.5	2.4	36.5	4.5	2.4	37.1	4.4	2.4
	80	35.3	4.0	2.6	36.3	4.0	2.6	37.3	4.0	2.7
10	60	27.3	4.7	1.7	27.7	4.6	1.7	28.1	4.6	1.8
	70	30.4	4.4	2.0	31.2	4.3	2.1	32.0	4.3	2.2
	80	33.4	4.0	2.4	34.7	4.0	2.5	35.9	4.0	2.7

NOTE: ALL CAPACITIES ARE NET (KBTUH) WITH INDOOR FAN HEAT ALREADY DEDUCTED AT 1250 BTUH/1000 CFM.

Multipliers for determining the performance with other indoor sections.

Air Handler	Coil	MBH	KW	COP
AHX60	-	1.00	1.02	0.98
F6FP060	-	0.99	1.01	0.98
MA20D	MC62D	1.00	1.00	1.00

Furnaces	Coils	MBH	KW	COP
T*(8,L)*X*C20	FC/MC62D	0.98	1.02	0.96
T*9X*D20	FC/MC62D	0.98	0.97	1.01