

# SUBMITTAL DATA SHEET

**R-410A SPLIT SYSTEM HEAT PUMP UNITS  
2.5 THRU 5 TONS  
MODELS: 13 SEER THJD30\* THRU 60 - 3 PHASE**

JOB NAME:			LOCATION:		
PURCHASER:			ORDER NO:		
ENGINEER:					
SUBMITTED TO:	FOR:	REF:	APPROVAL:	CONSTRUCTION:	
SUBMITTED BY:			DATE:		
UNIT DESIGNATION:			SCHEDULE NO.	MODEL NO.	

**PRODUCT DATA**

**Cooling Performance**

Total Capacity \_\_\_\_\_ MBH  
Outdoor Design Temp \_\_\_\_\_ °F

**Electrical Data**

Power Supply \_\_\_\_ / \_\_\_\_ / \_\_\_\_  
Compressor Ampacity \_\_\_\_\_ AMPs  
Total Unit Ampacity \_\_\_\_\_ AMPs  
Power Input Req \_\_\_\_\_ KW  
Minimum Wire Size \_\_\_\_\_ AWG  
Overcurrent Device  
 Fuses    Circuit Breaker

**Unit Weight**

Unit Weight \_\_\_\_\_ LBS

**DIMENSIONS - INCHES**

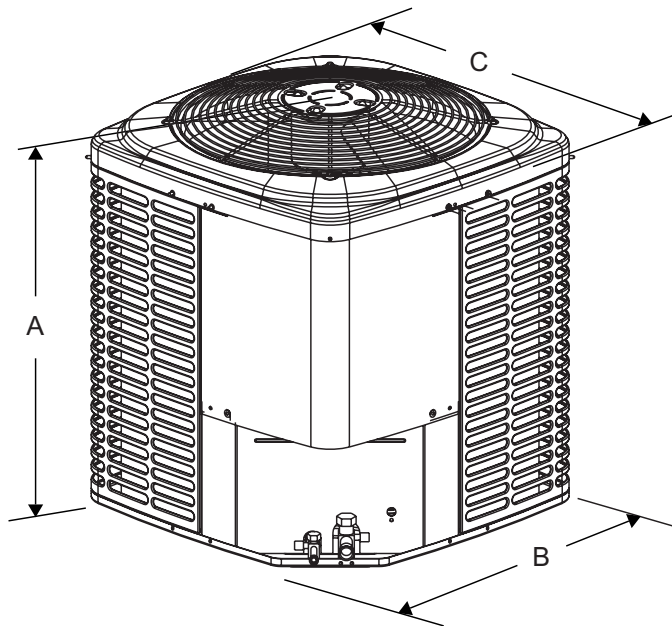

All dimensions are in inches. They are subject to change without notice. Certified dimensions will be provided upon request.



Unit Model	Dimensions (Inches)			Refrigerant Connection Service Valve Size	
	A <sup>1</sup>	B	C	Liquid	Vapor
30	36	34	34	3/8"	7/8"
36	40	34	34		
42	40	34	34		
48	40	34	34		
60	40	34	34		

1. Including Fan guard.

## FEATURES

- UL approval (units & accessories)
- CUL listed.
- Certified in accordance with the Unitary Small Equipment certification program, which the ARI Standard 210/240.
- 1-year limited parts warranty.
- 5-year limited warranty on the compressor.
- Copper tube aluminum fin coil.
- Internally protected compressor.
- High Pressure Switch
- Propeller type fan.
- Durable construction.
- Pre-painted steel cabinet.
- Factory wired.
- Sweat refrigerant connections.
- Re-useable brass service valves.
- Easy access to electrical compartment.
- Liquid line filter dryer.
- Powder coated fan guard and coil guard.
- 18 gauge G90 galvanized formed base pan.

## MATCHING AIR SIDE EQUIPMENT

Model No.  \_\_\_\_\_  
 Submittal Form No.  \_\_\_\_\_

## FIELD INSTALLED ACCESSORIES

Off Cycle Timer (2TD08700124)  \_\_\_\_\_  
 Thermostats  \_\_\_\_\_  
 Blower Off Delay (2FD06700224)  \_\_\_\_\_  
 Hard Start Kit  \_\_\_\_\_  
 Low Ambient Pressure Switch  \_\_\_\_\_

Model	Source 1 Kit numbers
18	S1-2SA06708606
24	S1-2SA06721706
30	S1-2SA06705906
36	S1-2SA06708906
42	S1-2SA06708806
48	S1-2SA06708806
60	S1-2SA06707906

## CLEARANCES

Service Access	24 Inches
All Other Sides	10 Inches
Above Unit	48 Inches
Below Unit	0 Inches

**NOTES:**

---



---



---



---