

SUBMITTAL DATA SHEET

**R-410A SPLIT SYSTEM HEAT PUMP UNITS
1.5 THRU 5 TONS
MODELS: 13 SEER THJR18 - 60**

JOB NAME:			LOCATION:		
PURCHASER:			ORDER NO:		
ENGINEER:					
SUBMITTED TO:	FOR:	REF:	APPROVAL:	CONSTRUCTION:	
SUBMITTED BY:			DATE:		
UNIT DESIGNATION:			SCHEDULE NO.	MODEL NO.	

PRODUCT DATA

Cooling Performance

Total Capacity _____ MBH

Outdoor Design Temp _____ °F

Electrical Data

Power Supply ____ / ____ / ____

Compressor Ampacity _____ AMPs

Total Unit Ampacity _____ AMPs

Power Input Req _____ KW

Minimum Wire Size _____ AWG

Overcurrent Device

Fuses Circuit Breaker

Unit Weight

Unit Weight _____ LBS

DIMENSIONS - INCHES

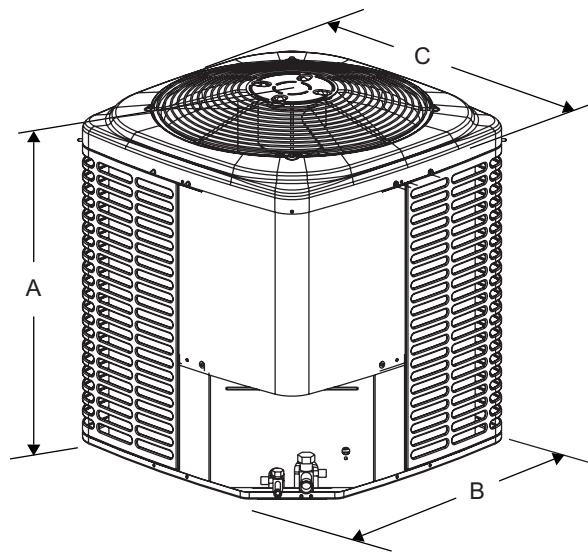

All dimensions are in inches. They are subject to change without notice. Certified dimensions will be provided upon request.

Unit Model	Dimensions (Inches)			Refrigerant Connection Service Valve Size	
	A ¹	B	C	Liquid	Vapor
18	28	23-1/2	23-1/2	3/8"	3/4"
24	28	23-1/2	23-1/2		
30	28	29	29		
36	28	34	34		7/8"
42	28	34	34		
48	40	34	34		
60	40	34	34		

1. Including Fan guard.



FEATURES

- UL approval (units & accessories)
- CUL listed.
- Certified in accordance with the Unitary Small Equipment certification program, which the ARI Standard 210/240.
- 5-year limited parts warranty.
- 5-year limited warranty on the compressor.
- Copper tube aluminum fin coil.
- Internally protected compressor.
- High Pressure Switch
- Propeller type fan.
- Durable construction.
- Pre-painted steel cabinet.
- Factory wired.
- Sweat refrigerant connections.
- Re-useable brass service valves.
- Easy access to electrical compartment.
- Liquid line filter dryer.
- Powder coated fan guard and coil guard.
- 18 gauge G90 galvanized formed base pan.

CLEARANCES

Service Access	24 Inches
All Other Sides	10 Inches
Above Unit	48 Inches
Below Unit	0 Inches

MATCHING AIR SIDE EQUIPMENT

Model No. _____
Submittal Form No. _____

FIELD INSTALLED ACCESSORIES

Off Cycle Timer (2TD08700124) _____
Thermostats _____
Blower Off Delay (2FD06700224) _____
Hard Start Kit _____
Low Ambient Pressure Switch _____

Model	Source 1 Kit numbers
18	S1-2SA06708606
24	S1-2SA06721706
30	S1-2SA06705906
36	S1-2SA06708906
42	S1-2SA06708806
48	S1-2SA06708806
60	S1-2SA06707906

NOTES:
