



HEATING & AIR CONDITIONING

TECHNICAL GUIDE

Echelon

R-410A SPLIT-SYSTEM AIR CONDITIONERS

18 SEER

MODELS: AC8B024 THRU 060*(C)
(2 THRU 5 NOMINAL TONS)



Due to continuous product improvement, specifications are subject to change without notice.

Visit us on the web at www.york.com

Additional rating information can be found at www.ahridirectory.org

WARRANTY

Standard 5-year limited parts warranty.

10-year limited compressor warranty.

Premium System Warranty - Limited lifetime compressor when matched with an approved Coleman Echelon furnace or UPG air handler and coil.

Extended 10-year limited parts warranty when product is registered online within 90 days of purchase for replacement or closing for new home construction.

DESCRIPTION

The 18 SEER Series unit is the outdoor part of a versatile climate system. It is designed with a matching indoor coil component from Johnson Controls Unitary Products. Available for typical applications this climate system is supported with accessories and documents to serve specific functions.

FEATURES

- **Superior Coil Protection** – A PVC coated steel coil guard completely protects coil from debris and other large damaging material while a polymer mesh further protects the coil against smaller particles.
- **Isolated Compressor Compartment** – A molded composite bulkhead isolates the compressor from the rest of the unit reducing sound and vibration.
- **Protected Compressors** – Each compressor is protected against abnormal pressures by an internal pressure relief valve and factory installed high and low pressure controls. Additional protection against moisture and debris is provided by factory installed liquid line filter driers.
- **Environmentally Friendly Refrigerant** – Next generation refrigerant R-410A delivers environmentally friendly performance with zero ozone depletion.
- **Durable Finish** – Automotive quality finish provides the ultimate protection from harmful U.V. rays and rust creep ensuring long-lasting high quality appearance. A powder-paint topcoat is applied over a baked-on primer, using a galvanized, zinc coated steel base material. The result is a finish that has been proven in testing to provide 33% greater durability than conventional powder-coat finishes.
- **Lower Installed Cost** – Designed to provide enhanced installability by featuring a slide-down control compartment and angled service valves to reduce overall installation time and cost.
- **Low Operating Sound Levels** – A fan design boasting technology adapted from aeronautic and defense engineering provides for whisper quiet operation by allowing airflow to flow smoothly and efficiently across the fan tips.
- **Filter-Drier** – A factory installed, solid core liquid line filter-drier filters harmful debris and moisture from the system.
- **Easy Service Access** – A full end, full service, access panel with handle makes for easy entry to internal components.
- **Composite Base** - Strong and durable composite base pan resists rust and corrosion while it helps reduce vibrations and noise.
- **Whisper drive system** - Features combination of swept-wing fan, composite base pan, isolated compressor compartment and two-stage compressor to reduce overall sound to a mere whisper.
- **Low RPM fan motor** - Helps to reduce airflow noise.
- **Agency Listed** - U.L. and C.U.L. listed - approved for outdoor application. The unit is certified in accordance with the Unitary Small Equipment certification program, which is based on ARI Standard 210/240.

Physical and Electrical Data

MODEL	AC8B024F3(C)	AC8B036F3(C)	AC8B048F3(C)	AC8B060F3(C)
Unit Supply Voltage	208-230V, 1 ϕ , 60Hz			
Normal Voltage Range ¹	187 to 252			
Minimum Circuit Ampacity	15.6	23.6	29.2	34.8
Max. Overcurrent Device Amps ²	25	40	50	60
Min. Overcurrent Device Amps ³	20	25	30	35
Multi-stage Compressor	Yes	Yes	Yes	Yes
Compressor Type	Scroll	Scroll	Scroll	Scroll
Compressor Amps	Rated Load	10.3	16.7	21.2
	Locked Rotor	52	82	96
Crankcase Heater	No	No	No	No
Fan Motor Amps	Rated Load	2.8	2.8	2.8
Fan Diameter Inches	24	24	24	24
Fan Motor	Rated HP	1/3	1/3	1/3
	Nominal RPM	685	685	685
	Nominal CFM	2900	3200	3100
Coil	Face Area Sq. Ft.	23.58	23.58	23.58
	Rows Deep	2	2	2
	Fins / Inch	16	16	14
Liquid Line Set OD (Field Installed)	3/8	3/8	3/8	3/8
Vapor Line Set OD (Field Installed)	3/4	3/4	7/8	7/8
Unit Charge (Lbs. - Oz.) ⁴	15 - 1	13 - 7	12 - 9	13 - 5
Charge Per Foot, Oz.	0.62	0.62	0.67	0.67
Operating Weight Lbs.	305	305	310	330

1 Rated in accordance with ARI Standard 110, utilization range "A".

2 Dual element fuses or HACR circuit breaker. Maximum allowable overcurrent protection.

3 Dual element fuses or HACR circuit breaker. Minimum recommended overcurrent protection.

4 The Unit Charge is correct for the outdoor unit, matched indoor coil and 15 feet of refrigerant tubing. For tubing lengths other than 15 feet, add or subtract the amount of refrigerant, using the difference in length multiplied by the per foot value.

All dimensions are in inches. They are subject to change without notice. Certified dimensions will be provided upon request.

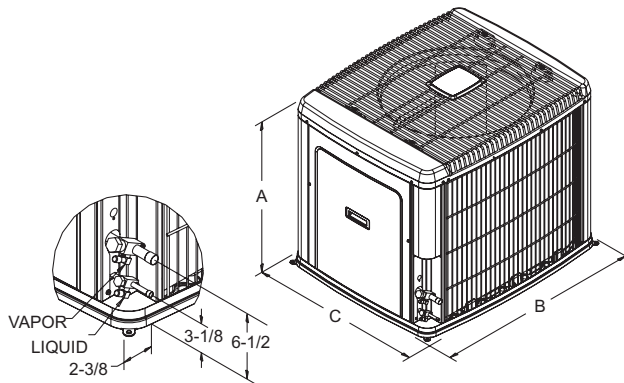

Unit Model	Dimensions (Inches)			Refrigerant Connection Service Valve Size	
	A	B	C	Liquid	Vapor
24	39-1/2	42	34	3/8"	3/4"
36	39-1/2	42	34		7/8"
48	39-1/2	42	34		
60	39-1/2	42	34		

System Charge for Various Matched Systems				
Outdoor Unit	AC8B024F3(C)	AC8B036F3(C)	AC8B048F3(C)	AC8B060F3(C)
Approved System Thermal Expansion Valve ¹	1TVM4F1	1TVM4H1	1TVM4J1	1TVM4K1
Factory Charge, lbs-oz	15 - 1	13 - 7	12 - 9	13 - 5
Indoor Coil ²	TXV Kit ³ - Additional Charge, Oz			
AHX18	0	-	-	-
AHX24	10	-	-	-
AHX30	12	-	-	-
AHX36	18	12	-	-
AHX42	-	22	-	-
AHX48	-	21	9	-
AHX60	-	27	15	14
AV24	2	-	-	-
AV36	19	12	-	-
AV/SV48	-	21	10	-
AV/SV60	-	-	10	7
F*FV060	-	-	0	0
F*FP048	-	-	-	-
F*FP060	-	-	-	-
FC/MC/PC30	4	-	-	-
FC/MC/PC32	12	-	-	-
FC/MC/PC35	12	6	-	-
FC/MC/PC36	5	0	-	-
FC/MC/PC37	18	12	-	-
FC/MC/PC42	-	3	-	-
FC/MC/PC43	18	12	-	-
FC/MC/PC48	29	21	10	-
FC/MC/PC60	-	-	9	7
FC/MC62	-	27	15	14
HC30	10	-	-	-
HC36	12	-	-	-
HC42	-	11	-	-
HC60	-	-	0	0
HD36	23	-	-	-
HD48	-	30	20	-
HD60	-	-	26	14
UC30	4	-	-	-
UC36	4	1	-	-
UC42	-	3	-	-
UC48	22	16	5	-
UC60	-	-	10	9

FOOTNOTES:

- 1 Systems matched with furnace or air handlers not equipped with blower-off delays may require blower Time Delay Kit 2FD06700224.
- 2 PC coils cannot be used in downflow or horizontal applications. FC coils cannot be used in horizontal applications.
- 3 A TXV kit must be used with these coils to obtain system performance.

Note: If a TXV is factory installed on the coil, it must be replaced with the listed TXV.

PROCEDURES:

1. Unit factory charge listed on the unit nameplate includes refrigerant for the condenser, the smallest evaporator and 15 feet of interconnecting line tubing.
2. Verify the TXV and additional charge required for specific evaporator coil in the system using the above table.
3. Additional charge for the amount of interconnecting line tubing greater than 15 feet at the rate specified in Physical and Electrical Data Table.
4. For TXV matches requiring additional charge, the refrigerant needs to be weighed in for specific coil match and lineset length.
5. Permanently mark the unit nameplate with the total system charge. Total System Charge = Base Charge (as shipped) + adder for evaporator + adder for line set.

COOLING CAPACITY - With Air Handler Coils

UNIT MODEL	AIR HANDLER		COIL MODEL ¹	COOLING					
	MODEL	W		STAGE	RATED CFM	NET MBH		SEER	EER
1 PH 18 SEER AC WITH MV									
AC8B024F3(C)	MV12B	17	FC/MC/PC35B	1	620	18.2	13.8	17.05	13.80
				2	800	23.6	17.2		
	MV12B	17	FC/MC/PC35C	1	620	18.2	13.8	17.05	13.80
				2	800	23.6	17.2		
	MV12B	17	FC/MC/PC43B	1	620	18.5	14.0	17.20	14.00
				2	800	24.0	17.5		
	MV12B	17	FC/MC/PC43C	1	620	18.5	14.0	17.20	14.00
				2	800	24.0	17.5		
	MV12D	24	FC/MC/PC48D	1	645	18.9	14.3	18.00	14.45
				2	835	24.6	17.9		
AC8B036F3(C)	MV12B	17	FC/MC/PC43B	1	775	25.6	18.0	17.70	13.55
				2	1200	36.0	25.2		
	MV16C	21	FC/MC/PC43C	1	775	25.7	18.1	18.00	14.00
				2	1200	36.2	25.3		
	MV12D	24	FC/MC/PC48D	1	735	25.6	18.0	18.40	13.95
				2	1135	36.0	25.2		
	MV16C	21	FC/MC/PC48C	1	775	25.9	18.2	18.40	14.15
				2	1200	36.4	25.4		
	MV12D	24	FC/MC62D	1	735	25.7	18.1	18.50	14.25
				2	1135	36.6	25.6		
AC8B048F3(C)	MV16C	21	FC/MC/PC48C	1	1000	34.0	25.1	17.30	12.45
				2	1600	46.0	35.1		
	MV16C	21	FC/MC/PC48D	1	1000	34.0	25.1	17.30	12.45
				2	1600	46.0	35.1		
	MV20D	24	FC/MC/PC48D	1	1020	34.0	25.1	17.00	12.35
				2	1600	46.0	35.1		
	MV20D	24	FC/MC62D	1	1075	33.8	25.0	17.00	12.45
				2	1625	46.5	35.8		
AC8B060F3(C)	MV20D	24	FC/MC/PC60D	1	1030	40.2	27.3	15.30	11.55
				2	1800	55.5	40.5		
	MV20D	24	FC/MC62D	1	1030	42.1	28.6	16.00	12.00
				2	1800	58.0	42.3		
1 PH 18 SEER AC WITH AV / SV / F*FV									
AC8B024F3(C)	AV*24	17	-	1	540	17.4	12.2	16.50	13.25
				2	800	23.8	16.7		
	AV*36	21	-	1	505	17.6	12.2	17.00	13.75
				2	725	24.0	16.5		
AC8B036F3(C)	AV*36	21	-	1	765	24.8	17.1	18.00	13.50
				2	1190	36.0	25.3		
	AV/SV*48	24	-	1	815	25.2	17.6	18.00	13.50
				2	1220	36.2	25.5		
AC8B048F3(C)	AV/SV*48	24	-	1	1055	33.1	24.4	16.00	11.75
				2	1625	45.0	34.0		
	AV/SV*60	24	-	1	995	32.6	23.7	16.00	11.75
				2	1560	45.0	33.6		
	F4FV060	24	-	1	1200	33.6	24.8	16.85	12.15
				2	1600	44.5	34.0		
AC8B060F3(C)	AV/SV*60	24	-	1	1095	41.5	27.2	15.00	11.50
				2	1730	56.5	38.7		
	F4FV060	24	-	1	1200	41.8	28.4	15.55	11.60
				2	1780	55.5	40.5		

For Notes See Page 5.

COOLING CAPACITY - With Air Handler Coils (Continued)

UNIT MODEL	AIR HANDLER		COIL MODEL ¹	COOLING					
	MODEL	W		STAGE	RATED CFM	NET MBH	SEER	EER	
1 PH 18 SEER AC WITH AHX									
AC8B024F3(C)	AHX18	17	-	1	535	17.1	12.1	16.25	13.00
				2	835	23.4	16.6		
	AHX24	17	-	1	540	17.4	12.3	16.50	13.25
				2	800	23.8	16.8		
	AHX30	17	-	1	545	17.6	12.6	16.75	13.50
				2	820	24.2	17.3		
	AHX36	21	-	1	505	17.4	12.1	15.75	13.00
				2	820	24.0	17.1		
AC8B036F3(C)	AHX36	21	-	1	770	24.8	17.1	18.00	13.50
				2	1225	36.0	25.3		
	AHX42	21	-	1	990	26.2	19.6	18.50	13.75
				2	1190	36.6	25.8		
	AHX48	24	-	1	885	25.2	18.2	18.00	13.50
				2	1255	36.2	25.8		
	AHX60	24	-	1	1005	26.6	20.7	18.25	13.75
				2	1300	37.0	26.7		
AC8B048F3(C)	AHX48	24	-	1	1070	33.1	24.7	16.00	11.75
				2	1660	45.0	34.4		
	AHX60	24	-	1	1075	32.6	24.0	16.00	11.75
				2	1680	45.0	34.3		
AC8B060F3(C)	AHX60	24	-	1	1075	41.5	27.2	15.00	11.25
				2	1905	56.5	39.9		

Rated in accordance with DOE test procedures (Federal Register 12-27-79 and 3-18-88) and ARI Standards 210.
Cooling MBH based on 80°F entering air temperature, 50% RH, and rated air flow.
EER (Energy Efficiency Ratio) is the total cooling output in BTU's at 95°F outdoor ambient divided by the total electric power in watt-hours at those conditions.
SEER (Seasonal Energy Efficiency Ratio) is the total cooling output in BTU's during a normal annual usage period for cooling divided by the total electric power input in watt-hours during the same period.

1 MC coils available with a factory installed horizontal drain pan. See price pages for specific model number.

— = Not applicable.

COOLING CAPACITY - Upflow, Downflow & Horizontal Furnaces and Coils

UNIT MODEL	FURNACE**		COIL MODEL	COOLING					
	CFM RANGE (Min.-max.)	W		STAGE	RATED CFM	NET MBH		SEER ¹	EER
						TOTAL	SENS.		
AC8B024F3(C)	550 - 650	21,24	FC/MC/PC48	1	600	19.0	14.6	17.95	14.45
	650 - 950			2	865	25.8	18.8		
AC8B036F3(C)	800 - 1000	24	FC/MC62	1	805	25.6	18.0	18.30	14.20
	1000 - 1400			2	1170	37.6	26.2		
AC8B048F3(C)	1000 - 1400	24	FC/MC62	1	1200	33.8	25.4	14.50	11.50
	1400 - 1800			2	1600	45.5	34.2		
AC8B060F3(C)	1150 - 1550	24	FC/MC62	1	1160	42.5	28.0	16.00	12.00
	1600 - 2000			2	1855	58.5	40.0		

1 Requires a 2FD06700224 Blower Time Delay unless a standard furnace is equipped with one.

** Refer to Quick Selection Chart for specific furnace match-up.

COOLING CAPACITY - With High Efficiency Motor Furnaces

UNIT MODEL	FURNACE MODEL	COIL MODEL ¹	W	COOLING					
				STAGE	RATED CFM	NET MBH		SEER	EER
						TOTAL	SENSIBLE		
1 PH 18 SEER AC WITH HIGH EFFICIENCY FURNACES²									
AC8B024F3(C)	T*(8,L)X*A12	FC/MC/PC30A	14	1	555	17.7	12.5	16.75	13.50
				2	775	23.0	16.1		
	T*(8,L)X*B12	FC/MC/PC30B	17	1	645	17.8	13.3	17.00	13.50
				2	835	23.2	16.6		
	T*9X*B12	FC/MC/PC30B	17	1	595	17.7	12.9	16.75	13.50
				2	775	23.0	16.1		
	T*(8,L)X*A12	FC/MC/PC32A	14	1	530	17.5	12.3	16.50	13.25
				2	800	23.0	16.3		
	T*(8,L)X*B12	FC/MC/PC35B	17	1	675	17.4	13.4	16.50	13.50
				2	850	23.0	16.4		
	T*(8,L)X*C16	FC/MC/PC35C	21	1	625	18.0	13.4	17.00	14.00
				2	865	24.2	17.5		
	T*(8,L)X*C20	FC/MC/PC35C	21	1	710	18.8	14.9	17.00	14.00
				2	885	24.2	17.6		
	T*9X*B12	FC/MC/PC35B	17	1	620	17.5	12.9	16.50	13.25
				2	785	23.2	16.4		
	T*9X*C16	FC/MC/PC35C	21	1	610	18.0	13.2	16.75	14.00
				2	765	24.0	16.7		
	T*(8,L)X*A12	FC/MC/PC36A	14	1	555	17.8	12.7	16.75	13.50
				2	815	23.0	16.4		
	T*(8,L)X*B12	FC/MC/PC36B	17	1	670	17.5	13.2	16.75	13.75
				2	835	23.0	16.6		
	T*(8,L)X*C16	FC/MC/PC36C	21	1	675	18.4	13.9	17.25	14.00
				2	875	24.0	17.6		
	T*9X*B12	FC/MC/PC36B	17	1	600	17.9	13.0	16.75	13.50
				2	775	23.2	16.5		
	T*9X*C16	FC/MC/PC36C	21	1	665	18.4	13.8	17.25	14.00
				2	815	24.0	17.2		
	T*(8,L)X*A12	FC/MC/PC37A	14	1	640	18.0	13.4	16.75	13.50
				2	840	23.6	17.0		
	T*(8,L)X*B12	FC/MC/PC43B	17	1	700	17.5	13.5	16.75	13.75
				2	865	23.4	17.0		
	T*9X*C16	FC/MC/PC43C	21	1	645	18.4	13.7	17.25	14.00
				2	785	24.2	17.1		
	T*(8,L)X*C16	FC/MC/PC48C	21	1	685	18.8	14.4	17.75	14.25
				2	875	24.8	18.1		
T*9X*C16	FC/MC/PC48C	21	1	680	18.6	14.3	17.50	14.25	
			2	815	24.4	17.6			
T*(8,L)X*B12	HD36	17	1	655	17.0	12.8	16.00	13.25	
			2	855	22.6	15.8			
T*(8,L)X*A12	UC30A	14	1	555	17.7	12.7	16.75	13.50	
			2	785	23.2	16.3			
T*(8,L)X*B12	UC30B	17	1	645	17.8	13.3	17.25	13.75	
			2	835	23.2	16.4			
T*9X*B12	UC30B	17	1	595	17.8	13.0	17.00	13.50	
			2	775	23.2	16.2			
T*(8,L)X*B12	UC36B	17	1	670	16.6	12.4	16.00	13.25	
			2	835	22.2	15.8			
T*(8,L)X*C16	UC36C	21	1	665	17.6	13.2	16.50	13.50	
			2	875	23.8	17.1			
T*9X*B12	UC36B	17	1	600	17.0	12.5	16.00	13.00	
			2	775	22.4	15.6			

For Notes See Page 14.

COOLING CAPACITY - With High Efficiency Motor Furnaces (Continued)

UNIT MODEL	FURNACE MODEL	COIL MODEL ¹	W	COOLING					
				STAGE	RATED CFM	NET MBH		SEER	EER
						TOTAL	SENSIBLE		
1 PH 18 SEER AC WITH HIGH EFFICIENCY FURNACES²									
AC8B024F3(C)	T*9X*C16	UC36C	21	1	665	17.6	13.1	16.50	13.75
				2	815	23.4	16.7		
	T*(8,L)X*C16	UC48C	21	1	675	17.8	13.4	16.75	13.75
				2	875	24.0	17.1		
	T*9X*C16	UC48C	21	1	670	17.7	13.4	16.75	13.75
				2	815	23.8	17.0		
	(C*(8,L)C/T*8V)*A12	FC/MC/PC30A	14	1	590	18.2	13.4	16.75	13.50
				2	805	24.6	17.4		
	(C*(8,L)C/T*8V)*B12	FC/MC/PC30B	17	1	565	18.2	13.2	17.00	13.50
				2	815	24.6	17.6		
	(C*9C/T*9V)*B12	FC/MC/PC30B	17	1	565	17.7	13.1	16.75	13.50
				2	790	23.0	16.3		
	(C*(8,L)C/T*8V)*A12	FC/MC/PC32A	14	1	550	18.0	13.0	16.50	13.25
				2	775	24.4	17.3		
	(C*(8,L)C/T*8V)*B12	FC/MC/PC35B	17	1	515	17.8	12.7	16.50	13.50
				2	760	24.4	17.3		
	(C*9C/T*9V)*B12	FC/MC/PC35B	17	1	550	17.5	12.7	16.50	13.25
				2	815	23.2	16.5		
	(C*(8,L)C/T*8V)*A12	FC/MC/PC36A	14	1	595	18.4	13.6	17.00	13.50
				2	805	24.8	17.5		
	(C*(8,L)C/T*8V)*B12	FC/MC/PC36B	17	1	525	18.0	12.8	16.75	13.75
				2	765	24.6	17.2		
	(C*9C/T*9V)*B12	FC/MC/PC36B	17	1	590	17.9	13.2	16.75	13.50
				2	815	23.2	16.6		
	(C*(8,L)C/T*8V)*B12	FC/MC/PC43B	17	1	515	18.0	12.8	16.75	13.75
				2	760	24.8	17.5		
	(C*9C/T*9V)*B12	FC/MC/PC43B	17	1	550	17.8	12.9	17.00	13.75
				2	800	23.6	16.7		
	(C*(8,L)C/T*8V)*A12	HC30	14	1	550	17.4	12.6	16.25	13.25
				2	775	22.8	15.9		
(C*(8,L)C/T*8V)*A12	HD36	14	1	595	17.5	12.6	16.50	13.25	
			2	805	23.0	15.7			
(C*(8,L)C/T*8V)*B12	HD36	17	1	515	17.0	11.9	16.00	13.25	
			2	760	22.6	15.5			
(C*9C/T*9V)*B12	HD36	17	1	590	17.5	12.6	16.50	13.50	
			2	815	23.0	15.7			
(C*(8,L)C/T*8V)*A12	UC30A	14	1	590	17.7	13.2	16.75	13.50	
			2	805	23.2	16.3			
(C*(8,L)C/T*8V)*B12	UC30B	17	1	565	17.8	13.3	17.25	13.75	
			2	815	23.2	16.3			
(C*9C/T*9V)*B12	UC30B	17	1	565	17.8	13.2	17.00	13.50	
			2	790	23.2	16.3			
(C*(8,L)C/T*8V)*A12	UC36A	14	1	595	17.0	12.8	16.00	13.00	
			2	805	22.4	15.7			
(C*(8,L)C/T*8V)*B12	UC36B	17	1	525	16.6	11.9	16.00	13.25	
			2	765	22.2	15.5			
(C*9C/T*9V)*B12	UC36B	17	1	590	17.0	12.8	16.00	13.00	
			2	815	22.4	15.7			

For Notes See Page 14.

COOLING CAPACITY - With High Efficiency Motor Furnaces (Continued)

UNIT MODEL	FURNACE MODEL	COIL MODEL ¹	W	COOLING					
				STAGE	RATED CFM	NET MBH		SEER	EER
						TOTAL	SENSIBLE		
1 PH 18 SEER AC WITH HIGH EFFICIENCY FURNACES²									
AC8B036F3(C)	T*(8,L)X*B12	FC/MC/PC35B	17	1	820	24.6	17.1	17.00	12.50
				2	1290	35.0	25.0		
	T*(8,L)X*C16	FC/MC/PC35C	21	1	585	23.0	14.8	16.25	13.25
				2	1105	35.0	24.2		
	T*(8,L)X*C20	FC/MC/PC35C	21	1	750	24.4	16.6	16.75	13.25
				2	1225	35.2	24.8		
	T*9X*B12	FC/MC/PC35B	17	1	760	24.4	16.7	16.75	12.75
				2	1265	35.2	24.9		
	T*9X*C16	FC/MC/PC35C	21	1	675	23.6	15.9	17.00	13.00
				2	1270	35.4	25.1		
	T*9X*C20	FC/MC/PC35C	21	1	790	24.6	17.0	17.00	12.75
				2	1195	35.6	24.8		
	T*(8,L)X*A12	FC/MC/PC36A	14	1	750	24.2	16.5	16.75	12.50
				2	1185	34.6	23.9		
	T*(8,L)X*B12	FC/MC/PC36B	17	1	810	24.6	17.0	17.00	12.75
				2	1255	34.8	24.5		
	T*(8,L)X*C16	FC/MC/PC36C	21	1	635	23.6	15.4	16.75	13.25
				2	1100	34.8	23.6		
	T*(8,L)X*C20	FC/MC/PC36C	21	1	795	24.4	17.0	17.25	13.00
				2	1265	35.0	24.7		
	T*9X*B12	FC/MC/PC36B	17	1	750	24.2	16.6	17.00	12.75
				2	1245	34.8	24.2		
	T*9X*C16	FC/MC/PC36C	21	1	725	24.2	16.4	17.25	12.75
				2	1275	34.6	24.6		
	T*9X*C20	FC/MC/PC36C	21	1	830	24.6	17.2	17.25	12.75
				2	1195	35.2	24.3		
	T*(8,L)X*A12	FC/MC/PC37A	14	1	810	24.2	16.9	16.75	13.00
				2	1290	34.2	24.4		
	T*(8,L)X*B12	FC/MC/PC42B	17	1	840	24.6	17.4	17.25	13.00
				2	1160	34.8	24.1		
	T*(8,L)X*C16	FC/MC/PC42C	21	1	680	23.8	15.8	17.00	13.50
				2	1200	35.4	25.0		
T*(8,L)X*C20	FC/MC/PC42C	21	1	845	24.6	17.4	17.25	13.25	
			2	1270	35.0	24.8			
T*9X*B12	FC/MC/PC42B	17	1	775	24.4	16.7	17.00	12.50	
			2	1275	34.8	24.8			
T*9X*C16	FC/MC/PC42C	21	1	765	24.4	16.7	17.25	13.00	
			2	1260	34.8	24.6			
T*(8,L)X*B12	FC/MC/PC43B	17	1	835	24.8	17.5	17.25	12.75	
			2	1300	35.4	25.3			
T*(8,L)X*C16	FC/MC/PC43C	21	1	615	23.6	15.3	17.00	13.75	
			2	1175	35.8	25.1			
T*(8,L)X*C20	FC/MC/PC43C	21	1	780	24.8	17.2	17.50	13.50	
			2	1250	35.8	25.6			
T*9X*B12	FC/MC/PC43B	17	1	775	24.8	17.2	17.00	12.75	
			2	1270	35.4	25.6			
T*9X*C16	FC/MC/PC43C	21	1	695	24.4	16.3	17.25	13.00	
			2	1260	35.6	25.2			
T*9X*C20	FC/MC/PC43C	21	1	810	24.8	17.3	17.25	13.25	
			2	1185	35.8	25.1			
T*(8,L)X*C16	FC/MC/PC48C	21	1	645	24.2	15.9	17.25	13.75	
			2	1185	36.4	25.7			

For Notes See Page 14.

COOLING CAPACITY - With High Efficiency Motor Furnaces (Continued)

UNIT MODEL	FURNACE MODEL	COIL MODEL ¹	W	COOLING					
				STAGE	RATED CFM	NET MBH		SEER	EER
						TOTAL	SENSIBLE		
1 PH 18 SEER AC WITH HIGH EFFICIENCY FURNACES²									
AC8B036F3(C)	T*(8,L)X*C20	FC/MC/PC48C	21	1	810	24.8	17.4	17.50	13.75
				2	1270	36.2	26.0		
	T*9X*C16	FC/MC/PC48C	21	1	720	24.8	16.8	17.75	13.25
				2	1280	36.2	26.1		
	T*9X*C20	FC/MC/PC48C	21	1	830	24.8	17.6	17.50	13.25
				2	1205	36.6	25.8		
	T*9X*D20	FC/MC/PC48D	24	1	870	25.6	18.4	18.00	13.75
				2	1240	36.8	26.0		
	T*9X*D20	FC/MC62D	24	1	830	25.4	18.0	17.75	13.75
				2	1225	36.8	26.0		
	T*9X*D20	HD48	24	1	830	25.0	17.7	17.25	13.50
				2	1260	36.6	26.2		
	T*(8,L)X*A12	UC36A	14	1	750	23.8	16.1	16.50	12.25
				2	1225	34.0	23.7		
	T*(8,L)X*B12	UC36B	17	1	810	24.0	16.6	16.75	12.50
				2	1255	34.2	23.8		
	T*(8,L)X*C16	UC36C	21	1	635	23.0	14.9	16.50	13.00
				2	1100	34.4	23.4		
	T*(8,L)X*C20	UC36C	21	1	795	24.0	16.5	16.75	13.00
				2	1265	34.4	24.2		
	T*9X*C20	UC36C	21	1	830	24.2	16.9	16.75	12.75
				2	1195	34.8	24.2		
	T*(8,L)X*B12	UC42B	17	1	840	24.4	17.0	17.00	13.00
				2	1160	34.6	23.9		
	T*(8,L)X*C16	UC42C	21	1	680	23.4	15.5	16.75	13.25
				2	1200	35.0	24.5		
	T*(8,L)X*C20	UC42C	21	1	845	24.4	17.0	17.25	13.25
				2	1270	35.0	24.7		
	T*9X*B12	UC42B	17	1	775	24.2	16.4	16.75	12.50
				2	1275	34.6	24.4		
	T*9X*C16	UC42C	21	1	765	24.2	16.4	17.00	13.00
				2	1260	34.8	24.5		
	T*(8,L)X*C16	UC48C	21	1	645	23.4	15.4	16.75	13.50
				2	1185	35.6	25.3		
	T*(8,L)X*C20	UC48C	21	1	810	24.4	17.2	17.25	13.50
				2	1270	35.4	25.4		
	T*9X*C16	UC48C	21	1	720	24.0	16.4	17.25	13.00
				2	1280	35.6	25.7		
	T*9X*C20	UC48C	21	1	830	24.6	17.5	17.25	13.00
				2	1205	35.8	25.4		
T*9X*D20	UC48D	24	1	870	24.8	18.0	17.50	13.25	
			2	1240	36.0	25.8			
(C*(8,L)C/T*8V)*B12	FC/MC/PC35B	17	1	775	25.4	17.9	17.00	12.50	
			2	1150	37.0	26.2			
(C*(8,L)C/T*8V)*C16	FC/MC/PC35C	21	1	770	25.4	18.0	17.25	13.25	
			2	1210	37.4	27.0			
(C*(8,L)C/T*8V)*C20	FC/MC/PC35C	21	1	1005	26.8	20.4	17.25	13.25	
			2	1170	37.4	26.6			
(C*9C/T*9V)*B12	FC/MC/PC35B	17	1	810	25.0	17.4	16.75	12.75	
			2	1190	35.2	24.5			
(C*9C/T*9V)*C16	FC/MC/PC35C	21	1	790	25.0	17.5	17.25	13.00	
			2	1215	35.4	24.7			

For Notes See Page 14.

COOLING CAPACITY - With High Efficiency Motor Furnaces (Continued)

UNIT MODEL	FURNACE MODEL	COIL MODEL ¹	W	COOLING					
				STAGE	RATED CFM	NET MBH		SEER	EER
						TOTAL	SENSIBLE		
1 PH 18 SEER AC WITH HIGH EFFICIENCY FURNACES²									
AC8B036F3(C)	(C*9C/T*9V)*C20	FC/MC/PC35C	21	1	760	24.6	16.8	17.00	12.75
				2	1330	35.6	25.3		
	(C*(8,L)C/T*8V)*A12	FC/MC/PC36A	14	1	815	25.6	18.3	16.75	12.50
				2	1190	36.8	25.8		
	(C*(8,L)C/T*8V)*B12	FC/MC/PC36B	17	1	745	25.4	17.7	17.00	12.75
				2	1220	37.0	26.2		
	(C*(8,L)C/T*8V)*C16	FC/MC/PC36C	21	1	805	25.8	18.3	17.50	13.00
				2	1235	37.0	26.8		
	(C*(8,L)C/T*8V)*C20	FC/MC/PC36C	21	1	800	25.8	18.3	17.30	13.25
				2	1240	37.2	26.8		
	(C*9C/T*9V)*B12	FC/MC/PC36B	17	1	800	25.0	17.3	17.00	12.75
				2	1165	34.8	23.9		
	(C*9C/T*9V)*C16	FC/MC/PC36C	21	1	915	25.4	18.2	17.25	13.00
				2	1185	34.6	24.1		
	(C*9C/T*9V)*C20	FC/MC/PC36C	21	1	760	24.6	16.8	17.25	12.75
				2	1320	35.2	25.1		
	(C*(8,L)C/T*8V)*A12	FC/MC/PC37A	14	1	730	25.6	17.7	16.75	13.00
				2	1150	37.4	26.6		
	(C*(8,L)C/T*8V)*B12	FC/MC/PC42B	17	1	760	25.6	18.0	17.25	13.00
				2	1175	37.2	26.2		
	(C*(8,L)C/T*8V)*C16	FC/MC/PC42C	21	1	825	25.0	17.6	17.50	13.50
				2	1205	35.4	24.7		
	(C*(8,L)C/T*8V)*C20	FC/MC/PC42C	21	1	735	25.2	17.5	17.50	13.50
				2	1170	37.2	26.6		
	(C*9C/T*9V)*B12	FC/MC/PC42B	17	1	800	25.0	17.5	17.00	12.50
				2	1195	34.8	24.3		
	(C*9C/T*9V)*C16	FC/MC/PC42C	21	1	780	24.6	16.9	17.25	13.25
				2	1205	34.8	24.3		
	(C*9C/T*9V)*C20	FC/MC/PC42C	21	1	770	24.8	17.0	17.25	13.00
				2	1325	35.4	25.5		
	(C*(8,L)C/T*8V)*B12	FC/MC/PC43B	17	1	860	26.4	19.2	17.25	12.75
				2	1270	37.8	27.8		
	(C*(8,L)C/T*8V)*C16	FC/MC/PC43C	21	1	770	26.0	18.3	17.50	13.50
				2	1190	38.0	27.4		
	(C*(8,L)C/T*8V)*C20	FC/MC/PC43C	21	1	745	25.8	18.1	17.50	13.50
				2	1190	38.5	27.4		
(C*9C/T*9V)*B12	FC/MC/PC43B	17	1	815	25.0	17.5	17.00	12.75	
			2	1200	35.4	24.9			
(C*9C/T*9V)*C16	FC/MC/PC43C	21	1	815	25.2	17.5	17.25	13.00	
			2	1240	35.6	25.1			
(C*9C/T*9V)*C20	FC/MC/PC43C	21	1	780	24.8	16.9	17.25	13.25	
			2	1200	35.8	25.1			
(C*(8,L)C/T*8V)*C16	FC/MC/PC48C	21	1	810	26.4	19.0	17.75	13.50	
			2	1210	38.5	28.0			
(C*(8,L)C/T*8V)*C20	FC/MC/PC48C	21	1	720	25.8	18.0	17.50	13.75	
			2	1155	38.5	27.4			
(C*9C/T*9V)*C16	FC/MC/PC48C	21	1	780	25.6	17.9	17.75	13.50	
			2	1195	36.2	25.5			
(C*9C/T*9V)*C20	FC/MC/PC48C	21	1	745	24.8	17.1	17.50	13.25	
			2	1330	36.6	26.5			
(C*(8,L)C/T*8V)*C16	HC42	21	1	800	25.0	17.6	17.50	13.50	
			2	1205	35.8	25.1			

For Notes See Page 14.

COOLING CAPACITY - With High Efficiency Motor Furnaces (Continued)

UNIT MODEL	FURNACE MODEL	COIL MODEL ¹	W	COOLING					
				STAGE	RATED CFM	NET MBH		SEER	EER
						TOTAL	SENSIBLE		
1 PH 18 SEER AC WITH HIGH EFFICIENCY FURNACES²									
AC8B036F3(C)	(C*(8,L)C/T*8V)*C20	HC42	21	1	745	24.8	17.0	17.50	13.50
				2	1190	35.8	25.1		
	(C*9C/T*9V)*C16	HC42	21	1	815	25.0	17.6	17.25	13.00
				2	1240	35.6	24.9		
	(C*9C/T*9V)*C20	HC42	21	1	780	25.0	17.6	17.50	13.25
				2	1200	35.8	25.1		
	(C*(8,L)C/T*8V)*B12	HD48	17	1	750	24.8	17.0	17.25	13.25
				2	1210	35.8	25.1		
	(C*9C/T*9V)*B12	HD48	17	1	710	24.6	16.5	17.00	13.00
				2	1150	35.4	24.3		
	(C*(8,L)C/T*8V)*C16	HD48	21	1	810	25.4	17.7	17.75	13.75
				2	1210	36.0	25.3		
	(C*(8,L)C/T*8V)*C20	HD48	21	1	720	24.8	16.7	17.50	13.75
				2	1155	35.8	24.9		
	(C*9C/T*9V)*C16	HD48	21	1	780	25.4	17.6	17.50	13.50
				2	1195	36.0	25.1		
	(C*9C/T*9V)*C20	HD48	21	1	745	24.8	16.9	17.25	13.25
				2	1330	36.2	26.1		
	(C*(8,L)C/T*8V)*A12	UC36A	14	1	815	24.4	16.9	16.50	12.25
				2	1190	34.0	23.3		
	(C*(8,L)C/T*8V)*B12	UC36B	17	1	745	24.0	16.3	16.75	12.50
				2	1220	34.2	23.7		
	(C*(8,L)C/T*8V)*C16	UC36C	21	1	805	24.6	17.0	17.25	13.00
				2	1235	34.4	23.5		
	(C*(8,L)C/T*8V)*C20	UC36C	21	1	800	24.6	17.1	17.25	13.00
				2	1240	34.4	23.5		
	(C*9C/T*9V)*B12	UC36B	17	1	800	24.4	17.0	16.75	12.75
				2	1165	34.2	23.5		
	(C*9C/T*9V)*C16	UC36C	21	1	915	25.0	17.8	17.00	13.00
				2	1185	34.4	23.7		
	(C*9C/T*9V)*C20	UC36C	21	1	760	24.2	16.5	16.75	12.75
				2	1300	34.8	24.9		
	(C*(8,L)C/T*8V)*B12	UC42B	17	1	760	24.4	16.8	17.00	13.00
				2	1175	34.6	23.9		
	(C*(8,L)C/T*8V)*C16	UC42C	21	1	825	24.8	17.4	17.25	13.50
				2	1205	35.0	24.5		
	(C*(8,L)C/T*8V)*C20	UC42C	21	1	735	24.4	16.8	17.25	13.50
				2	1170	35.0	24.1		
	(C*9C/T*9V)*B12	UC42B	17	1	800	24.8	17.3	16.75	12.50
				2	1195	34.6	24.1		
(C*9C/T*9V)*C16	UC42C	21	1	780	24.4	16.7	17.00	13.00	
			2	1205	34.8	23.9			
(C*9C/T*9V)*C20	UC42C	21	1	770	24.4	16.9	17.00	13.00	
			2	1325	35.4	25.1			
(C*(8,L)C/T*8V)*C16	UC48C	21	1	810	25.0	17.7	17.50	13.50	
			2	1210	35.6	25.3			
(C*(8,L)C/T*8V)*C20	UC48C	21	1	720	24.4	16.7	17.25	13.50	
			2	1155	35.4	24.7			
(C*9C/T*9V)*C16	UC48C	21	1	780	25.0	17.7	17.50	13.25	
			2	1195	35.6	25.1			
(C*9C/T*9V)*C20	UC48C	21	1	755	24.6	17.1	17.25	13.00	
			2	1330	35.8	25.9			

For Notes See Page 14.

COOLING CAPACITY - With High Efficiency Motor Furnaces (Continued)

UNIT MODEL	FURNACE MODEL	COIL MODEL ¹	W	COOLING					
				STAGE	RATED CFM	NET MBH		SEER	EER
						TOTAL	SENSIBLE		
1 PH 18 SEER AC WITH HIGH EFFICIENCY FURNACES²									
AC8B048F3(C)	T*(8,L)X*C16	FC/MC/PC48C	21	1	1115	33.4	25.0	16.00	11.50
				2	1600	45.5	34.4		
	T*(8,L)X*C20	FC/MC/PC48C	21	1	855	31.8	22.5	15.50	11.75
				2	1660	45.5	34.8		
	T*9X*C20	FC/MC/PC48C	21	1	1215	33.4	25.4	16.00	11.75
				2	1615	45.5	34.2		
	T*9X*D20	FC/MC/PC48D	24	1	1250	33.0	25.4	16.00	11.50
				2	1635	45.0	34.0		
	T*(8,L)X*C16	FC/PC60C	21	1	1120	32.6	24.5	15.75	11.50
				2	1605	44.5	33.3		
	T*(8,L)X*C20	FC/PC60C	21	1	860	31.4	22.3	15.50	11.75
				2	1595	45.0	33.6		
	T*(8,L)X*C20	FC/MC/PC60D	21	1	860	31.4	22.3	15.50	11.75
				2	1595	45.0	33.6		
	T*9X*C20	FC/PC60C	21	1	1215	31.4	25.7	14.50	11.00
				2	1625	43.5	34.2		
	T*9X*D20	FC/MC/PC60D	24	1	1300	32.4	25.1	16.00	11.75
				2	1490	44.5	32.9		
	T*(8,L)X*C16	FC/MC62D	21	1	1115	33.8	25.1	16.25	11.75
				2	1610	45.5	34.4		
	T*(8,L)X*C20	FC/MC62D	21	1	835	31.6	22.3	15.75	12.00
				2	1665	46.0	35.0		
	T*9X*C20	FC/MC62D	21	1	1220	34.2	26.1	16.00	11.75
				2	1595	45.5	34.4		
	T*9X*D20	FC/MC62D	24	1	1240	33.0	25.2	16.25	11.50
				2	1610	45.0	34.0		
	T*(8,L)X*C16	HD48	21	1	1115	32.8	24.7	15.75	11.50
				2	1610	45.5	34.4		
	T*9X*C20	HD48	21	1	1220	33.0	25.4	15.50	11.75
				2	1625	45.0	34.4		
	T*(8,L)X*C16	UC48C	21	1	1115	30.6	22.7	14.50	11.00
				2	1600	42.5	31.4		
T*9X*C20	UC48C	21	1	1180	31.2	23.3	14.25	11.00	
			2	1605	43.0	32.0			
T*9X*D20	UC48D	24	1	1185	29.8	22.3	14.75	11.00	
			2	1605	42.0	31.5			
T*(8,L)X*C16	UC60C	21	1	1120	30.0	22.2	14.75	11.00	
			2	1605	42.0	31.3			
T*(8,L)X*C20	UC60C	21	1	860	29.2	20.5	14.25	11.50	
			2	1540	43.0	32.0			
T*(8,L)X*C20	UC60D	21	1	860	29.2	20.5	14.25	11.50	
			2	1540	43.0	32.0			
T*9X*D20	UC60D	24	1	1215	30.0	22.6	14.75	11.00	
			2	1490	42.0	31.1			
(C*(8,L)C/T*8V)*C16	FC/MC/PC48C	21	1	1035	34.4	25.8	16.50	11.75	
			2	1615	47.0	37.2			
(C*(8,L)C/T*8V)*C20	FC/MC/PC48C	21	1	1080	33.4	24.4	16.25	11.75	
			2	1640	45.5	34.4			
(C*9C/T*9V)*C16	FC/MC/PC48C	21	1	1050	33.4	24.6	16.25	11.75	
			2	1590	45.5	34.1			
(C*9C/T*9V)*C20	FC/MC/PC48C	21	1	1055	33.4	24.6	16.50	11.75	
			2	1655	45.5	34.1			
(C*9C/T*9V)*D20	FC/MC/PC48D	24	1	1060	33.0	24.2	16.25	11.50	
			2	1645	45.0	34.0			

For Notes See Page 14.

COOLING CAPACITY - With High Efficiency Motor Furnaces (Continued)

UNIT MODEL	FURNACE MODEL	COIL MODEL ¹	W	COOLING					
				STAGE	RATED CFM	NET MBH		SEER	EER
						TOTAL	SENSIBLE		
1 PH 18 SEER AC WITH HIGH EFFICIENCY FURNACES²									
AC8B048F3(C)	(C*(8,L)C/T*8V)*C16	FC/PC60C	21	1	1025	33.8	25.2	16.25	11.75
				2	1600	46.5	36.2		
	(C*(8,L)C/T*8V)*C20	FC/PC60C	21	1	1060	34.0	25.8	16.25	12.00
				2	1620	46.5	36.6		
	(C*9C/T*9V)*C16	FC/PC60C	21	1	1050	32.4	23.8	16.00	11.50
				2	1590	44.5	33.6		
	(C*9C/T*9V)*C20	FC/PC60C	21	1	1055	32.6	23.8	16.00	11.50
				2	1655	44.5	33.6		
	(C*9C/T*9V)*D20	FC/MC/PC60D	24	1	1070	32.4	23.8	16.00	11.75
				2	1615	44.5	33.8		
	(C*9C/T*9V)*D20	FC/MC62D	24	1	1085	33.0	24.4	16.25	11.75
				2	1630	45.0	34.0		
	(C*9C/T*9V)*D20	HC60	24	1	1070	32.0	23.6	15.75	11.50
				2	1615	44.0	33.6		
	(C*(8,L)C/T*8V)*C16	HD48	21	1	1035	32.8	24.0	16.25	11.75
				2	1615	45.5	33.9		
	(C*(8,L)C/T*8V)*C20	HD48	21	1	1080	32.8	24.0	16.00	11.75
				2	1640	45.5	33.7		
	(C*9C/T*9V)*C16	HD48	21	1	1050	33.0	24.0	16.25	11.75
				2	1590	45.0	33.5		
	(C*9C/T*9V)*C20	HD48	21	1	1055	33.0	24.0	16.25	11.75
				2	1655	45.0	33.5		
	(C*9C/T*9V)*D20	HD48	24	1	1060	32.8	24.0	16.25	11.75
				2	1645	45.5	33.7		
	(C*(8,L)C/T*8V)*C16	HD60	21	1	1035	33.6	24.6	16.75	12.00
				2	1625	45.5	34.6		
	(C*(8,L)C/T*8V)*C20	HD60	21	1	1015	33.6	24.6	16.75	12.00
				2	1605	45.5	34.8		
	(C*9C/T*9V)*C16	HD60	21	1	1050	33.4	24.6	16.25	11.75
				2	1590	45.5	34.6		
	(C*9C/T*9V)*C20	HD60	21	1	1055	33.6	24.6	16.50	11.75
				2	1655	45.5	34.6		
	(C*9C/T*9V)*D20	HD60	24	1	1070	33.6	24.6	16.50	11.75
				2	1615	45.5	34.6		
	(C*(8,L)C/T*8V)*C16	UC48C	21	1	1035	31.8	23.4	15.75	11.50
				2	1615	44.0	33.4		
	(C*(8,L)C/T*8V)*C20	UC48C	21	1	1080	31.8	23.4	15.50	11.50
				2	1640	44.0	33.4		
	(C*9C/T*9V)*C16	UC48C	21	1	1050	31.8	23.8	15.50	11.25
				2	1590	43.5	33.0		
(C*9C/T*9V)*C20	UC48C	21	1	1055	31.8	23.8	15.75	11.25	
			2	1630	43.5	33.0			
(C*9C/T*9V)*D20	UC48D	24	1	1060	29.8	22.0	14.75	11.00	
			2	1570	42.0	31.1			
(C*(8,L)C/T*8V)*C16	UC60C	21	1	1035	30.0	21.4	15.00	11.25	
			2	1570	42.0	31.1			
(C*(8,L)C/T*8V)*C20	UC60C	21	1	1015	30.0	21.4	15.00	11.50	
			2	1590	42.5	31.3			
(C*9C/T*9V)*C16	UC60C	21	1	1050	30.0	21.2	14.75	11.00	
			2	1570	42.0	31.1			
(C*9C/T*9V)*C20	UC60C	21	1	1055	30.0	21.4	14.75	11.00	
			2	1570	42.0	31.1			
(C*9C/T*9V)*D20	UC60D	24	1	1070	30.0	21.2	14.75	11.00	
			2	1570	42.0	31.1			

For Notes See Page 14.

COOLING CAPACITY - With High Efficiency Motor Furnaces (Continued)

UNIT MODEL	FURNACE MODEL	COIL MODEL ¹	W	COOLING					
				STAGE	RATED CFM	NET MBH		SEER	EER
						TOTAL	SENSIBLE		
1 PH 18 SEER AC WITH HIGH EFFICIENCY FURNACES²									
AC8B060F3(C)	T*(8,L)X*C16	FC/PC60C	21	1	1120	41.0	27.1	15.00	11.50
				2	1605	55.5	37.3		
	T*(8,L)X*C20	FC/PC60C	21	1	860	39.0	24.5	15.00	11.75
				2	1690	56.5	37.3		
	T*(8,L)X*C20	FC/MC/PC60D	21	1	860	39.0	24.5	15.00	11.75
				2	1690	56.5	37.3		
	T*9X*C20	FC/PC60C	21	1	1215	40.0	27.5	14.50	11.00
				2	1625	54.5	37.1		
	T*9X*D20	FC/MC/PC60D	24	1	1320	42.0	29.1	15.50	11.75
				2	1730	56.5	38.7		
	T*9X*C20	FC/MC/PC60D	21	1	1295	42.0	28.7	15.50	11.75
				2	1645	56.0	37.7		
	T*(8,L)X*C20	FC/MC62D	21	1	835	38.5	24.3	14.75	11.75
				2	1665	57.0	39.2		
	T*9X*C20	FC/MC62D	21	1	1220	42.0	28.5	15.25	11.75
				2	1595	56.5	38.2		
	T*9X*D20	FC/MC62D	24	1	1240	40.5	27.3	15.00	11.25
				2	1645	55.0	37.6		
	T*9X*D20	HD60	24	1	1240	40.5	27.2	15.25	11.00
				2	1645	54.5	36.3		
	T*(8,L)X*C16	UC60C	21	1	1120	39.5	26.3	14.75	11.25
				2	1605	54.5	36.5		
	T*(8,L)X*C20	UC60C	21	1	860	38.0	23.5	14.25	11.50
				2	1690	55.5	36.5		
	T*(8,L)X*C20	UC60D	21	1	860	38.0	23.5	14.50	11.50
				2	1690	55.5	36.5		
	T*9X*D20	UC60D	24	1	1320	38.5	26.2	14.50	10.75
				2	1730	53.5	36.8		
	T*9X*C20	UC60C	21	1	1295	41.0	27.7	14.75	11.50
				2	1645	55.0	37.1		
	T*9X*C20	UC60D	21	1	1295	41.0	27.7	15.00	11.50
				2	1645	55.0	37.1		
(C*(8,L)C/T*8V)*C20	FC/PC60C	21	1	1060	40.5	25.8	15.20	11.25	
			2	1620	56.5	36.8			
(C*9C/T*9V)*C20	FC/PC60C	21	1	1055	40.0	25.8	15.00	11.00	
			2	1655	54.5	35.9			
(C*9C/T*9V)*D20	FC/MC62D	24	1	1085	40.5	26.3	15.00	11.25	
			2	1630	55.0	36.3			
(C*9C/T*9V)*D20	HC60	24	1	1070	39.0	25.4	14.50	10.75	
			2	1615	53.5	34.9			
(C*(8,L)C/T*8V)*C20	HD60	21	1	1015	40.5	25.8	15.25	11.50	
			2	1605	55.5	36.1			
(C*9C/T*9V)*C20	HD60	21	1	1055	40.5	26.3	15.25	11.00	
			2	1655	55.5	36.3			
(C*9C/T*9V)*D20	HD60	24	1	1070	40.5	26.5	15.25	11.00	
			2	1615	54.5	35.5			
(C*(8,L)C/T*8V)*C20	UC60C	21	1	1015	38.5	24.6	14.50	11.00	
			2	1605	53.5	34.6			
(C*9C/T*9V)*C20	UC60C	21	1	1055	38.5	24.6	14.25	10.75	
			2	1655	53.0	34.4			
(C*9C/T*9V)*D20	UC60D	24	1	1070	38.5	25.0	14.50	10.75	
			2	1615	53.5	34.6			

1 MC coils available with a factory installed horizontal drain pan.

2 Variable speed furnaces have B.O.D (Blower on Delay) standard.

ACCESSORIES*

Hard Start Kit (024-31994-000, 024-31995-000) - Provides increased starting torque for areas with low voltage.

TXV Kits - 1TVM9 series thermal expansion valves precisely meter refrigerant for optimum performance

Dehumidistat (2HU16700124) - Provides increased dehumidification when matched with variable speed furnace or air handler.

Thermostats - Compatible thermostat controls are available through accessory sourcing. For optimum performance and installation, refer to the UPGNET "Low Voltage Wiring Diagram" document to select and apply controls.

SOUND POWER RATINGS*

UNIT MODEL	(dBA)
024	71
036	73
048	72
060	74

* Rated in accordance with ARI 270-95 Standards.

COOLING PERFORMANCE DATA - LOW CFM 1-STAGE OPERATION																
OUTDOOR UNIT MODEL NO.		AC8B024F3(C)														
INDOOR COIL MODEL NO.		FC48D + MV12D														
CONDENSER ENTERING AIR TEMPERATURE	ID CFM	550					600					650				
	ID DB (°F)	80	80	75	80	80	80	80	75	80	80	80	80	75	80	80
	ID WB (°F)	57	62	62	67	72	57	62	62	67	72	57	62	62	67	72
65	T.C.	18.6	19.9	18.9	21.7	23.9	19.0	19.9	19.1	21.8	24.4	19.4	20.0	19.3	22.0	24.9
	S.C.	18.6	17.5	14.9	14.8	11.7	19.2	18.5	15.6	15.5	12.1	19.7	19.4	16.2	16.2	12.5
	K.W.	0.76	0.75	0.76	0.74	0.74	0.75	0.75	0.75	0.73	0.74	0.75	0.75	0.75	0.73	0.74
75	T.C.	17.8	18.8	18.0	20.6	22.8	18.3	18.9	18.3	20.9	23.2	18.7	19.1	18.5	21.1	23.6
	S.C.	17.9	17.1	14.5	14.4	11.3	18.4	17.9	15.1	15.1	11.8	18.9	18.6	15.8	15.9	12.2
	K.W.	0.93	0.92	0.93	0.91	0.90	0.92	0.92	0.92	0.90	0.90	0.91	0.91	0.92	0.90	0.90
85	T.C.	17.1	17.6	17.1	19.5	21.6	17.5	17.9	17.4	19.9	22.0	17.9	18.2	17.7	20.2	22.3
	S.C.	17.2	16.8	14.0	14.0	10.9	17.7	17.3	14.7	14.8	11.4	18.1	17.9	15.4	15.5	11.9
	K.W.	1.09	1.09	1.09	1.08	1.06	1.08	1.08	1.09	1.07	1.06	1.07	1.08	1.08	1.06	1.05
95	T.C.	16.4	16.5	16.2	18.5	20.5	16.8	16.9	16.6	18.9	20.8	17.1	17.2	16.9	19.4	21.0
	S.C.	16.5	16.4	13.6	13.7	10.5	17.0	16.8	14.3	14.4	11.1	17.4	17.2	15.0	15.1	11.7
	K.W.	1.26	1.26	1.26	1.24	1.22	1.24	1.25	1.25	1.24	1.22	1.24	1.24	1.25	1.23	1.21
105	T.C.	15.3	15.4	14.9	17.0	19.0	15.7	15.8	15.2	17.3	19.1	16.0	16.2	15.5	17.7	19.3
	S.C.	15.4	15.2	13.0	13.2	10.1	15.8	15.6	13.6	13.9	10.5	16.2	16.0	14.3	14.5	11.0
	K.W.	1.48	1.49	1.49	1.47	1.45	1.47	1.48	1.48	1.47	1.45	1.46	1.47	1.48	1.46	1.45
115	T.C.	14.2	14.3	13.6	15.5	17.5	14.6	14.7	13.9	15.8	17.6	15.0	15.1	14.1	16.1	17.7
	S.C.	14.4	14.1	12.4	12.8	9.6	14.7	14.5	13.0	13.4	10.0	15.1	14.9	13.5	13.9	10.4
	K.W.	1.70	1.71	1.71	1.70	1.68	1.69	1.70	1.70	1.69	1.67	1.68	1.69	1.70	1.68	1.67
125	T.C.	13.1	13.2	12.3	14.0	15.9	13.5	13.6	12.5	14.3	16.0	13.9	14.0	12.7	14.5	16.1
	S.C.	13.3	13.0	11.8	12.3	9.2	13.6	13.4	12.3	12.9	9.5	14.0	13.8	12.8	13.4	9.7
	K.W.	1.92	1.93	1.93	1.92	1.91	1.91	1.92	1.93	1.91	1.90	1.91	1.91	1.92	1.91	1.90

NOTE: ALL CAPACITIES ARE NET (KBTUH) WITH INDOOR FAN HEAT ALREADY DEDUCTED AT 1250 BTUH/1000 CFM.

Multipliers for determining the performance with other indoor sections.

NOTE: For dry bulb temperatures different than those listed (between 73-87 F), sensible capacity increases by 1060 BTUH per 1000 CFM per degree above the listed temperature and decreases by 1060 BTUH per 1000 CFM per degree below the listed temperature.

NOTE: KW RATING IS FOR OUTDOOR AND INDOOR UNITS.

LOW CFM

Air Handler	Coil	T.C.	S.C.	KW
AV*24	–	0.92	0.85	1.01
AV*36	–	0.93	0.85	1.00
AHX18	–	0.90	0.84	1.01
AHX24	–	0.92	0.86	1.01
AHX30	–	0.93	0.88	1.02
AHX36	–	0.92	0.84	1.06
MV12B	FC/MC/PC35B	0.96	0.97	1.01
MV12B	FC/MC/PC35C	0.96	0.97	1.01
MV12B	FC/MC/PC35B	0.98	0.98	1.02
MV12B	FC/MC/PC35C	0.98	0.98	1.02
MV12D	FC/MC/PC48D	1.00	1.00	1.00

Continued on next page.

Furnaces	Coil	T.C.	S.C.	KW
T*(8,L)X*A12	FC/MC/PC30A	0.94	0.87	1.01
T*(8,L)X*B12	FC/MC/PC30B	0.94	0.92	0.99
T*9X*B12	FC/MC/PC30B	0.94	0.90	1.01
T*(8,L)X*A12	FC/MC/PC32A	0.93	0.86	1.01
T*(8,L)X*B12	FC/MC/PC35B	0.92	0.93	1.01
T*(8,L)X*C16	FC/MC/PC35C	0.95	0.93	1.02
T*(8,L)X*C20	FC/MC/PC35C	0.99	1.03	1.05
T*9X*B12	FC/MC/PC35B	0.93	0.90	0.99
T*9X*C16	FC/MC/PC35C	0.95	0.92	1.02
T*(8,L)X*A12	FC/MC/PC36A	0.94	0.88	1.01
T*(8,L)X*B12	FC/MC/PC36B	0.93	0.92	0.99
T*(8,L)X*C16	FC/MC/PC36C	0.97	0.97	1.01
T*9X*B12	FC/MC/PC36B	0.95	0.91	1.02
T*9X*C16	FC/MC/PC36C	0.97	0.96	1.01
T*(8,L)X*A12	FC/MC/PC37A	0.95	0.93	1.02
T*(8,L)X*B12	FC/MC/PC43B	0.93	0.94	0.99
T*9X*C16	FC/MC/PC43C	0.97	0.95	1.03
T*(8,L)X*C16	FC/MC/PC48C	0.99	1.00	1.01
T*9X*C16	FC/MC/PC48C	0.98	1.00	1.02
T*(8,L)X*B12	HD36	0.90	0.89	1.00
T*(8,L)X*A12	UC30A	0.94	0.88	1.01
T*(8,L)X*B12	UC30B	0.94	0.93	0.99
T*9X*B12	UC30B	0.94	0.91	1.01
T*(8,L)X*B12	UC36B	0.88	0.86	1.00
T*(8,L)X*C16	UC36C	0.93	0.92	1.02

Furnaces	Coil	T.C.	S.C.	KW
T*9X*B12	UC36B	0.90	0.87	1.00
T*9X*C16	UC36C	0.93	0.91	1.02
T*(8,L)X*C16	UC48C	0.94	0.93	1.03
T*9X*C16	UC48C	0.94	0.93	1.02
(C*(8,L)C/T*8V)*A12	FC/MC/PC30A	0.95	0.91	1.01
(C*(8,L)C/T*8V)*B12	FC/MC/PC30B	0.96	0.92	1.00
(C*9C/T*9V)B12	FC/MC/PC30B	0.95	0.91	1.01
(C*(8,L)C/T*8V)*A12	FC/MC/PC32A	0.94	0.89	1.01
(C*(8,L)C/T*8V)*B12	FC/MC/PC35B	0.93	0.86	1.00
(C*9C/T*9V)*B12	FC/MC/PC35B	0.94	0.89	1.00
(C*(8,L)C/T*8V)*A12	FC/MC/PC36A	0.96	0.92	1.00
(C*(8,L)C/T*8V)*B12	FC/MC/PC36B	0.94	0.88	0.99
(C*9C/T*9V)*B12	FC/MC/PC36B	0.96	0.92	1.01
(C*(8,L)C/T*8V)*A12	FC/MC/PC37A	0.97	0.93	1.02
(C*(8,L)C/T*8V)*B12	FC/MC/PC43B	0.94	0.88	0.99
(C*9C/T*9V)*B12	FC/MC/PC43B	0.96	0.90	1.00
(C*(8,L)C/T*8V)*A12	HC30	0.93	0.88	1.01
(C*(8,L)C/T*8V)*A12	HD36	0.94	0.88	1.01
(C*(8,L)C/T*8V)*B12	HD36	0.91	0.83	1.00
(C*9C/T*9V)*B12	HD36	0.94	0.88	1.01
(C*(8,L)C/T*8V)*A12	UC30A	0.95	0.92	1.01
(C*(8,L)C/T*8V)*B12	UC30B	0.96	0.92	1.00
(C*9C/T*9V)*B12	UC30B	0.95	0.92	1.01
(C*(8,L)C/T*8V)*A12	UC36A	0.91	0.89	1.01
(C*(8,L)C/T*8V)*B12	UC36B	0.89	0.83	1.00
(C*9C/T*9V)*B12	UC36B	0.91	0.89	1.01

COOLING PERFORMANCE DATA - HIGH CFM 2-STAGE OPERATION																
OUTDOOR UNIT MODEL NO.		AC8B024F3(C)														
INDOOR COIL MODEL NO.		FC48D + MV12D														
CONDENSER ENTERING AIR TEMPERATURE	ID CFM	700					800					900				
	ID DB (°F)	80	80	75	80	80	80	80	75	80	80	80	80	75	80	80
	ID WB (°F)	57	62	62	67	72	57	62	62	67	72	57	62	62	67	72
65	T.C.	23.1	25.7	25.0	28.6	30.7	24.3	26.0	26.1	28.8	31.1	25.5	26.3	27.1	28.9	31.6
	S.C.	22.6	21.4	17.9	18.3	14.5	23.8	23.1	19.5	19.1	15.3	25.0	24.8	21.0	20.0	16.1
	K.W.	1.12	1.14	1.14	1.16	1.17	1.13	1.14	1.14	1.16	1.18	1.15	1.15	1.15	1.17	1.19
75	T.C.	22.5	24.3	23.9	27.1	29.2	23.5	24.7	24.7	27.4	29.7	24.5	25.1	25.5	27.6	30.1
	S.C.	21.9	20.9	17.5	17.8	14.0	23.0	22.4	18.9	18.7	14.8	24.0	23.8	20.3	19.7	15.5
	K.W.	1.31	1.32	1.32	1.34	1.35	1.31	1.32	1.32	1.34	1.36	1.33	1.33	1.33	1.35	1.37
85	T.C.	21.8	22.9	22.8	25.6	27.7	22.6	23.4	23.4	26.0	28.2	23.4	23.8	23.9	26.4	28.7
	S.C.	21.3	20.4	17.2	17.3	13.6	22.1	21.6	18.4	18.4	14.3	22.9	22.7	19.6	19.4	15.0
	K.W.	1.49	1.50	1.50	1.52	1.53	1.49	1.50	1.50	1.52	1.54	1.51	1.51	1.51	1.54	1.55
95	T.C.	21.2	21.5	21.8	24.0	26.2	21.8	22.1	22.1	24.6	26.7	22.4	22.5	22.3	25.2	27.2
	S.C.	20.6	20.0	16.8	16.8	13.1	21.3	20.9	17.9	18.0	13.7	21.9	21.7	18.9	19.1	14.4
	K.W.	1.67	1.68	1.67	1.70	1.72	1.67	1.68	1.68	1.70	1.72	1.69	1.69	1.69	1.72	1.73
105	T.C.	20.1	20.3	20.4	22.6	24.5	20.6	20.9	20.7	23.0	25.0	21.2	21.4	20.9	23.5	25.5
	S.C.	19.5	19.0	16.2	16.3	12.6	20.1	19.8	17.2	17.3	13.2	20.7	20.5	18.2	18.4	13.8
	K.W.	1.93	1.93	1.93	1.95	1.97	1.93	1.94	1.93	1.96	1.98	1.95	1.95	1.94	1.97	1.99
115	T.C.	19.0	19.2	19.1	21.2	22.9	19.5	19.7	19.3	21.5	23.4	20.0	20.2	19.5	21.8	23.9
	S.C.	18.5	18.1	15.5	15.8	12.0	19.0	18.8	16.6	16.7	12.6	19.6	19.4	17.6	17.6	13.2
	K.W.	2.17	2.18	2.17	2.20	2.23	2.18	2.18	2.18	2.21	2.23	2.20	2.20	2.19	2.22	2.24
125	T.C.	17.9	18.0	17.7	19.8	21.3	18.4	18.5	17.9	20.0	21.8	18.9	19.1	18.1	20.2	22.2
	S.C.	17.4	17.2	14.9	15.3	11.5	17.9	17.8	15.9	16.1	12.1	18.4	18.3	16.9	16.9	12.6
	K.W.	2.42	2.42	2.42	2.45	2.48	2.43	2.43	2.42	2.45	2.48	2.45	2.45	2.44	2.47	2.50

NOTE: ALL CAPACITIES ARE NET (KBTUH) WITH INDOOR FAN HEAT ALREADY DEDUCTED AT 1250 BTUH/1000 CFM.

Multipliers for determining the performance with other indoor sections.

NOTE: For dry bulb temperatures different than those listed (between 73-87 F), sensible capacity increases by 1060 BTUH per 1000 CFM per degree above the listed temperature and decreases by 1060 BTUH per 1000 CFM per degree below the listed temperature.

NOTE: KW RATING IS FOR OUTDOOR AND INDOOR UNITS.

HIGH CFM

Air Handlers	Coils	T.C.	S.C.	KW
AV*24	-	0.97	0.93	1.06
AV*36	-	0.98	0.92	1.03
AHX18	-	0.95	0.92	1.06
AHX24	-	0.97	0.93	1.06
AHX30	-	0.98	0.96	1.05
AHX36	-	0.98	0.95	1.08
MV12B	FC/MC/PC35B	0.96	0.96	1.00
MV12B	FC/MC/PC35C	0.96	0.96	1.00
MV12B	FC/MC/PC35B	0.98	0.98	1.01
MV12B	FC/MC/PC35C	0.98	0.98	1.01
MV12D	FC/MC/PC48D	1.00	1.00	1.00
MV12D	UC48D	1.00	1.00	1.00

Continued on next page.

Furnaces	Coils	T.C.	S.C.	KW
T*(8,L)X*A12	FC/MC/PC30A	0.93	0.90	1.00
T*(8,L)X*B12	FC/MC/PC30B	0.94	0.92	1.01
T*9X*B12	FC/MC/PC30B	0.93	0.90	1.00
T*(8,L)X*A12	FC/MC/PC32A	0.93	0.91	1.02
T*(8,L)X*B12	FC/MC/PC35B	0.93	0.92	1.00
T*(8,L)X*C16	FC/MC/PC35C	0.98	0.97	1.02
T*(8,L)X*C20	FC/MC/PC35C	0.98	0.98	1.02
T*9X*B12	FC/MC/PC35B	0.94	0.91	1.03
T*9X*C16	FC/MC/PC35C	0.98	0.93	1.01
T*(8,L)X*A12	FC/MC/PC36A	0.93	0.91	1.00
T*(8,L)X*B12	FC/MC/PC36B	0.93	0.93	0.98
T*(8,L)X*C16	FC/MC/PC36C	0.98	0.98	1.01
T*9X*B12	FC/MC/PC36B	0.94	0.92	1.01
T*9X*C16	FC/MC/PC36C	0.98	0.96	1.01
T*(8,L)X*A12	FC/MC/PC37A	0.96	0.95	1.03
T*(8,L)X*B12	FC/MC/PC43B	0.95	0.95	1.00
T*9X*C16	FC/MC/PC43C	0.98	0.95	1.02
T*(8,L)X*C16	FC/MC/PC48C	1.01	1.01	1.02
T*9X*C16	FC/MC/PC48C	0.99	0.98	1.01
T*(8,L)X*B12	HD36	0.92	0.88	1.00
T*(8,L)X*A12	UC30A	0.94	0.91	1.01
T*(8,L)X*B12	UC30B	0.94	0.92	0.99
T*9X*B12	UC30B	0.94	0.90	1.01
T*(8,L)X*B12	UC36B	0.90	0.88	0.98
T*(8,L)X*C16	UC36C	0.97	0.95	1.04

Furnaces	Coils	T.C.	S.C.	KW
T*9X*B12	UC36B	0.91	0.87	1.01
T*9X*C16	UC36C	0.95	0.93	1.00
T*(8,L)X*C16	UC48C	0.98	0.95	1.03
T*9X*C16	UC48C	0.97	0.95	1.02
(C*(8,L)C/T*8V)*A12	FC/MC/PC30A	0.95	0.92	1.01
(C*(8,L)C/T*8V)*B12	FC/MC/PC30B	0.96	0.92	1.00
(C*9C/T*9V)*B12	FC/MC/PC30B	0.95	0.92	1.01
(C*(8,L)C/T*8V)*A12	FC/MC/PC32A	0.95	0.92	1.02
(C*(8,L)C/T*8V)*B12	FC/MC/PC35B	0.95	0.91	1.00
(C*9C/T*9V)*B12	FC/MC/PC35B	0.96	0.94	1.02
(C*(8,L)C/T*8V)*A12	FC/MC/PC36A	0.95	0.93	1.01
(C*(8,L)C/T*8V)*B12	FC/MC/PC36B	0.95	0.92	0.99
(C*9C/T*9V)*B12	FC/MC/PC36B	0.96	0.94	1.01
(C*(8,L)C/T*8V)*A12	FC/MC/PC37A	0.97	0.95	1.02
(C*(8,L)C/T*8V)*B12	FC/MC/PC43B	0.97	0.93	1.00
(C*9C/T*9V)*B12	FC/MC/PC43B	0.97	0.95	1.01
(C*(8,L)C/T*8V)*A12	HC30	0.94	0.90	1.02
(C*(8,L)C/T*8V)*A12	HD36	0.95	0.89	1.01
(C*(8,L)C/T*8V)*B12	HD36	0.94	0.88	1.00
(C*9C/T*9V)*B12	HD36	0.95	0.89	1.00
(C*(8,L)C/T*8V)*A12	UC30A	0.96	0.92	1.01
(C*(8,L)C/T*8V)*B12	UC30B	0.96	0.93	1.00
(C*9C/T*9V)*B12	UC30B	0.96	0.92	1.01
(C*(8,L)C/T*8V)*A12	UC36A	0.92	0.89	1.00
(C*(8,L)C/T*8V)*B12	UC36B	0.92	0.88	0.99
(C*9C/T*9V)*B12	UC36B	0.92	0.89	1.00

COOLING PERFORMANCE DATA - LOW CFM 1-STAGE OPERATION																
OUTDOOR UNIT MODEL NO.		AC8B036F3(C)														
INDOOR COIL MODEL NO.		FC62D + MV12D														
CONDENSER ENTERING AIR TEMPERATURE	ID CFM	750					800					850				
	ID DB (°F)	80	80	75	80	80	80	80	75	80	80	80	80	75	80	80
	ID WB (°F)	57	62	62	67	72	57	62	62	67	72	57	62	62	67	72
65	T.C.	25.4	26.8	27.2	29.7	32.8	25.9	27.0	27.3	30.1	33.0	26.4	27.2	27.5	30.4	33.2
	S.C.	25.0	22.9	19.4	19.3	15.3	25.6	23.7	19.9	19.8	15.7	26.1	24.6	20.4	20.2	16.1
	K.W.	1.00	0.99	0.99	0.96	0.93	0.99	0.98	0.98	0.95	0.92	0.97	0.97	0.97	0.94	0.91
75	T.C.	24.3	25.5	25.7	28.3	31.2	24.9	25.7	25.9	28.6	31.3	25.4	26.0	26.1	28.9	31.5
	S.C.	24.0	22.3	18.8	18.7	14.8	24.6	23.1	19.4	19.2	15.3	25.1	23.8	19.9	19.7	15.7
	K.W.	1.24	1.23	1.23	1.20	1.17	1.22	1.22	1.22	1.19	1.16	1.21	1.21	1.21	1.18	1.16
85	T.C.	23.3	24.2	24.3	26.9	29.5	23.8	24.5	24.5	27.2	29.7	24.3	24.7	24.8	27.5	29.8
	S.C.	23.0	21.8	18.3	18.2	14.4	23.6	22.4	18.8	18.7	14.9	24.1	23.0	19.3	19.2	15.3
	K.W.	1.47	1.47	1.47	1.44	1.41	1.46	1.46	1.46	1.43	1.41	1.45	1.45	1.45	1.42	1.40
95	T.C.	22.2	22.9	22.8	25.4	27.9	22.7	23.2	23.1	25.8	28.0	23.3	23.5	23.4	26.1	28.2
	S.C.	22.0	21.2	17.7	17.6	14.0	22.6	21.7	18.2	18.2	14.5	23.1	22.2	18.8	18.7	14.9
	K.W.	1.71	1.71	1.71	1.68	1.65	1.70	1.70	1.70	1.67	1.65	1.69	1.69	1.69	1.66	1.64
105	T.C.	20.8	21.3	21.0	23.6	26.0	21.3	21.7	21.3	23.8	26.1	21.9	22.1	21.5	24.1	26.2
	S.C.	20.6	20.0	16.8	16.8	13.4	21.2	20.5	17.4	17.4	13.7	21.7	21.0	17.9	17.9	14.1
	K.W.	2.03	2.03	2.03	2.01	1.98	2.02	2.02	2.02	2.00	1.97	2.00	2.01	2.01	1.99	1.97
115	T.C.	19.4	19.7	19.3	21.7	24.1	20.0	20.2	19.5	22.0	24.2	20.5	20.7	19.7	22.2	24.3
	S.C.	19.2	18.8	16.0	16.1	12.8	19.8	19.3	16.6	16.6	13.0	20.4	19.8	17.1	17.1	13.3
	K.W.	2.34	2.33	2.34	2.32	2.30	2.33	2.33	2.33	2.31	2.29	2.31	2.32	2.32	2.30	2.28
125	T.C.	18.0	18.2	17.5	19.9	22.2	18.6	18.8	17.7	20.1	22.3	19.1	19.3	18.0	20.4	22.4
	S.C.	17.8	17.6	15.2	15.3	12.2	18.4	18.1	15.8	15.8	12.3	19.0	18.5	16.4	16.3	12.5
	K.W.	2.65	2.64	2.65	2.63	2.62	2.64	2.64	2.65	2.63	2.61	2.62	2.63	2.64	2.62	2.60

NOTE: ALL CAPACITIES ARE NET (KBTUH) WITH INDOOR FAN HEAT ALREADY DEDUCTED AT 1250 BTUH/1000 CFM.

Multipliers for determining the performance with other indoor sections.

NOTE: For dry bulb temperatures different than those listed (between 73-87 F), sensible capacity increases by 1060 BTUH per 1000 CFM per degree above the listed temperature and decreases by 1060 BTUH per 1000 CFM per degree below the listed temperature.

NOTE: KW RATING IS FOR OUTDOOR AND INDOOR UNITS.

LOW CFM

Air Handlers	Coils	T.C.	S.C.	KW
AV*36	-	0.96	0.95	1.04
AV/SV*48	-	0.98	0.98	1.04
AHX36	-	0.96	0.95	1.04
AHX42	-	1.02	1.09	1.05
AHX48	-	0.98	1.01	1.04
AHX60	-	1.04	1.15	1.08
MV12B	FC/MC/PC43B	1.00	0.99	1.03
MV12B	FC/MC/PC43C	1.00	0.99	1.03
MV16C	FC/MC/PC43C	1.00	1.00	1.03
MV12D	FC/MC/PC48D	1.00	0.99	1.00
MV12D	UC48D	1.00	0.99	1.00
MV16C	FC/MC/PC48C	1.01	1.01	1.01
MV16C	FC/MC/PC48D	1.01	1.01	1.01
MV16C	UC48D	1.01	1.01	1.01
MV20D	FC/MC/PC48D	1.00	1.00	1.01
MV20D	UC48D	1.00	1.00	1.01
MV12D	FC/MC62D	1.00	1.00	1.00
MV20D	FC/MC62D	1.01	1.01	1.01

Continued on next page.

Furnaces	Coils	T.C.	S.C.	KW
T*(8,L)X*B12	FC/MC/PC35B	0.96	0.95	1.03
T*(8,L)X*C16	FC/MC/PC35C	0.89	0.83	1.02
T*(8,L)X*C20	FC/MC/PC35C	0.95	0.92	1.04
T*9X*B12	FC/MC/PC35B	0.95	0.93	1.04
T*9X*C16	FC/MC/PC35C	0.92	0.89	1.01
T*9X*C20	FC/MC/PC35C	0.96	0.95	1.05
T*(8,L)X*A12	FC/MC/PC36A	0.94	0.92	1.04
T*(8,L)X*B12	FC/MC/PC36B	0.96	0.94	1.03
T*(8,L)X*C16	FC/MC/PC36C	0.92	0.86	1.01
T*(8,L)X*C20	FC/MC/PC36C	0.95	0.95	1.04
T*9X*B12	FC/MC/PC36B	0.94	0.92	1.04
T*9X*C16	FC/MC/PC36C	0.94	0.91	1.02
T*9X*C20	FC/MC/PC36C	0.96	0.96	1.03
T*(8,L)X*A12	FC/MC/PC37A	0.94	0.94	1.04
T*(8,L)X*B12	FC/MC/PC42B	0.96	0.97	1.03
T*(8,L)X*C16	FC/MC/PC42C	0.93	0.88	1.02
T*(8,L)X*C20	FC/MC/PC42C	0.96	0.97	1.03
T*9X*B12	FC/MC/PC42B	0.95	0.93	1.03
T*9X*C16	FC/MC/PC42C	0.95	0.93	1.03
T*(8,L)X*B12	FC/MC/PC43B	0.96	0.97	1.04
T*(8,L)X*C16	FC/MC/PC43C	0.92	0.85	1.01
T*(8,L)X*C20	FC/MC/PC43C	0.96	0.96	1.02
T*9X*B12	FC/MC/PC43B	0.96	0.96	1.04
T*9X*C16	FC/MC/PC43C	0.95	0.91	1.03
T*9X*C20	FC/MC/PC43C	0.96	0.96	1.04
T*(8,L)X*C16	FC/MC/PC48C	0.94	0.89	1.02
T*(8,L)X*C20	FC/MC/PC48C	0.96	0.97	1.02
T*9X*C16	FC/MC/PC48C	0.96	0.94	1.01
T*9X*C20	FC/MC/PC48C	0.96	0.98	1.02
T*9X*D20	FC/MC/PC48D	1.00	1.02	1.04
T*9X*D20	FC/MC62D	0.99	1.00	1.03
T*9X*D20	HD48	0.97	0.98	1.03
T*(8,L)X*A12	UC36A	0.93	0.90	1.04
T*(8,L)X*B12	UC36B	0.93	0.92	1.03
T*(8,L)X*C16	UC36C	0.89	0.83	1.02
T*(8,L)X*C20	UC36C	0.93	0.92	1.05
T*9X*C20	UC36C	0.94	0.94	1.04
T*(8,L)X*B12	UC42B	0.95	0.94	1.03
T*(8,L)X*C16	UC42C	0.91	0.86	1.02
T*(8,L)X*C20	UC42C	0.95	0.94	1.03
T*9X*B12	UC42B	0.94	0.91	1.04
T*9X*C16	UC42C	0.94	0.91	1.02
T*(8,L)X*C16	UC48C	0.91	0.86	1.02
T*(8,L)X*C20	UC48C	0.95	0.96	1.03
T*9X*C16	UC48C	0.93	0.91	1.03
T*9X*C20	UC48C	0.96	0.97	1.03
T*9X*D20	UC48D	0.96	1.00	1.02
(C*(8,L)C/T*8V)*B12	FC/MC/PC35B	0.96	0.93	1.03
(C*9C/T*9V)*B12	FC/MC/PC35B	0.98	0.97	1.05
(C*(8,L)C/T*8V)*C16	FC/MC/PC35C	0.98	0.97	1.03
(C*(8,L)C/T*8V)*C20	FC/MC/PC35C	1.01	1.07	1.07
(C*9C/T*9V)*C16	FC/MC/PC35C	0.98	0.98	1.03

Furnaces	Coils	T.C.	S.C.	KW
(C*9C/T*9V)*C20	FC/MC/PC35C	0.96	0.94	1.03
(C*(8,L)C/T*8V)*A12	FC/MC/PC36A	0.97	0.96	1.05
(C*(8,L)C/T*8V)*B12	FC/MC/PC36B	0.96	0.93	1.02
(C*9C/T*9V)*B12	FC/MC/PC36B	0.97	0.97	1.04
(C*(8,L)C/T*8V)*C16	FC/MC/PC36C	0.98	0.97	1.02
(C*(8,L)C/T*8V)*C20	FC/MC/PC36C	0.98	0.97	1.02
(C*9C/T*9V)*C16	FC/MC/PC36C	0.99	1.02	1.05
(C*9C/T*9V)*C20	FC/MC/PC36C	0.96	0.94	1.02
(C*(8,L)C/T*8V)*A12	FC/MC/PC37A	0.95	0.89	1.02
(C*(8,L)C/T*8V)*B12	FC/MC/PC42B	0.97	0.94	1.02
(C*9C/T*9V)*B12	FC/MC/PC42B	0.98	0.98	1.04
(C*(8,L)C/T*8V)*C16	FC/MC/PC42C	0.98	0.98	1.02
(C*(8,L)C/T*8V)*C20	FC/MC/PC42C	0.97	0.95	1.01
(C*9C/T*9V)*C16	FC/MC/PC42C	0.97	0.94	1.02
(C*9C/T*9V)*C20	FC/MC/PC42C	0.97	0.95	1.02
(C*(8,L)C/T*8V)*B12	FC/MC/PC43B	0.97	0.94	1.03
(C*9C/T*9V)*B12	FC/MC/PC43B	0.98	0.98	1.04
(C*(8,L)C/T*8V)*C16	FC/MC/PC43C	0.99	0.98	1.03
(C*(8,L)C/T*8V)*C20	FC/MC/PC43C	0.97	0.95	1.01
(C*9C/T*9V)*C16	FC/MC/PC43C	0.98	0.98	1.04
(C*9C/T*9V)*C20	FC/MC/PC43C	0.97	0.94	1.02
(C*(8,L)C/T*8V)*C16	FC/MC/PC48C	1.00	1.00	1.02
(C*(8,L)C/T*8V)*C20	FC/MC/PC48C	0.97	0.94	1.01
(C*9C/T*9V)*C16	FC/MC/PC48C	1.00	1.00	1.03
(C*9C/T*9V)*C20	FC/MC/PC48C	0.97	0.95	1.02
(C*(8,L)C/T*8V)*C16	HC42	0.98	0.98	1.03
(C*(8,L)C/T*8V)*C20	HC42	0.97	0.95	1.01
(C*9C/T*9V)*C16	HC42	0.98	0.98	1.04
(C*9C/T*9V)*C20	HC42	0.98	0.98	1.02
(C*(8,L)C/T*8V)*B12	HD48	0.97	0.95	1.02
(C*(8,L)C/T*8V)*C16	HD48	0.99	0.99	1.02
(C*(8,L)C/T*8V)*C20	HD48	0.97	0.93	1.01
(C*9C/T*9V)*B12	HD48	0.96	0.92	1.02
(C*9C/T*9V)*C16	HD48	0.99	0.98	1.02
(C*9C/T*9V)*C20	HD48	0.97	0.94	1.02
(C*(8,L)C/T*8V)*A12	UC36A	0.95	0.95	1.05
(C*(8,L)C/T*8V)*B12	UC36B	0.94	0.91	1.02
(C*9C/T*9V)*B12	UC36B	0.96	0.95	1.04
(C*(8,L)C/T*8V)*C16	UC36C	0.96	0.95	1.02
(C*(8,L)C/T*8V)*C20	UC36C	0.96	0.95	1.02
(C*9C/T*9V)*C16	UC36C	0.98	1.00	1.05
(C*9C/T*9V)*C20	UC36C	0.95	0.92	1.02
(C*(8,L)C/T*8V)*B12	UC42B	0.96	0.94	1.02
(C*9C/T*9V)*B12	UC42B	0.97	0.96	1.04
(C*(8,L)C/T*8V)*C16	UC42C	0.97	0.97	1.02
(C*(8,L)C/T*8V)*C20	UC42C	0.96	0.94	1.01
(C*9C/T*9V)*C16	UC42C	0.96	0.93	1.02
(C*9C/T*9V)*C20	UC42C	0.96	0.94	1.02
(C*(8,L)C/T*8V)*C16	UC48C	0.98	0.99	1.02
(C*(8,L)C/T*8V)*C20	UC48C	0.95	0.93	1.01
(C*9C/T*9V)*C16	UC48C	0.98	0.99	1.03
(C*9C/T*9V)*C20	UC48C	0.97	0.95	1.03

COOLING PERFORMANCE DATA - HIGH CFM 2-STAGE OPERATION																
OUTDOOR UNIT MODEL NO.		AC8B036F3(C)														
INDOOR COIL MODEL NO.		FC62D + MV12D														
CONDENSER ENTERING AIR TEMPERATURE	ID CFM	1100					1200					1300				
	ID DB (°F)	80	80	75	80	80	80	80	75	80	80	80	80	75	80	80
	ID WB (°F)	57	62	62	67	72	57	62	62	67	72	57	62	62	67	72
65	T.C.	35.7	38.1	38.5	41.2	45.8	37.2	39.1	38.8	41.7	46.1	38.6	40.1	39.1	42.1	46.3
	S.C.	34.5	31.9	27.3	26.9	21.2	36.1	33.4	28.6	27.7	22.1	37.5	35.0	29.9	28.4	22.9
	K.W.	1.71	1.74	1.74	1.79	1.82	1.74	1.76	1.76	1.81	1.84	1.78	1.79	1.78	1.84	1.86
75	T.C.	34.6	36.5	36.7	39.5	43.6	35.9	37.4	37.1	40.0	43.9	37.1	38.2	37.5	40.4	44.2
	S.C.	33.6	31.1	26.5	26.0	20.6	34.8	32.6	27.6	27.0	21.4	36.0	34.1	28.8	27.9	22.1
	K.W.	1.98	2.00	2.00	2.05	2.07	2.00	2.02	2.01	2.06	2.09	2.04	2.05	2.04	2.09	2.12
85	T.C.	33.6	35.0	35.0	37.8	41.5	34.6	35.7	35.4	38.3	41.8	35.5	36.4	35.9	38.7	42.0
	S.C.	32.6	30.3	25.6	25.2	20.0	33.6	31.8	26.6	26.3	20.6	34.5	33.3	27.7	27.4	21.2
	K.W.	2.24	2.26	2.25	2.30	2.33	2.26	2.28	2.27	2.32	2.35	2.30	2.30	2.30	2.34	2.38
95	T.C.	32.5	33.4	33.2	36.1	39.4	33.3	34.0	33.7	36.6	39.6	34.0	34.5	34.2	37.1	39.8
	S.C.	31.6	29.4	24.7	24.3	19.4	32.3	31.0	25.6	25.6	19.9	33.0	32.4	26.6	26.9	20.3
	K.W.	2.50	2.52	2.51	2.55	2.59	2.52	2.53	2.53	2.57	2.60	2.56	2.56	2.56	2.59	2.63
105	T.C.	30.7	31.5	31.2	33.7	37.0	31.5	32.0	31.6	34.2	37.2	32.1	32.6	32.0	34.7	37.4
	S.C.	29.9	28.4	23.7	23.6	18.6	30.6	29.6	24.7	24.8	19.0	31.3	30.6	25.7	25.9	19.4
	K.W.	2.89	2.90	2.90	2.94	2.97	2.92	2.92	2.91	2.96	2.99	2.95	2.95	2.94	2.98	3.02
115	T.C.	29.0	29.6	29.2	31.3	34.7	29.7	30.2	29.5	31.8	34.9	30.4	30.7	29.8	32.3	35.0
	S.C.	28.3	27.5	22.8	22.9	17.9	29.0	28.2	23.8	23.9	18.2	29.6	28.9	24.8	24.9	18.5
	K.W.	3.28	3.28	3.27	3.32	3.35	3.30	3.29	3.29	3.33	3.37	3.33	3.32	3.31	3.35	3.40
125	T.C.	27.3	27.7	27.2	29.0	32.4	28.0	28.3	27.4	29.5	32.6	28.6	28.8	27.7	30.0	32.7
	S.C.	26.7	26.5	21.9	22.2	17.2	27.3	26.8	22.9	23.1	17.4	28.0	27.1	24.0	24.0	17.6
	K.W.	3.66	3.65	3.65	3.70	3.73	3.68	3.67	3.66	3.71	3.75	3.71	3.70	3.69	3.73	3.78

NOTE: ALL CAPACITIES ARE NET (KBTUH) WITH INDOOR FAN HEAT ALREADY DEDUCTED AT 1250 BTUH/1000 CFM.

Multipliers for determining the performance with other indoor sections.

NOTE: For dry bulb temperatures different than those listed (between 73-87 F), sensible capacity increases by 1060 BTUH per 1000 CFM per degree above the listed temperature and decreases by 1060 BTUH per 1000 CFM per degree below the listed temperature.

NOTE: KW RATING IS FOR OUTDOOR AND INDOOR UNITS.

HIGH CFM

Air Handlers	Coils	T.C.	S.C.	KW
AV*36	-	0.98	0.99	1.04
AV/SV*48	-	0.99	1.00	1.04
AHX36	-	0.98	0.99	1.04
AHX42	-	1.00	1.01	1.04
AHX48	-	0.99	1.01	1.04
AHX60	-	1.01	1.04	1.05
MV12B	FC/MC/PC43B	0.98	0.98	1.03
MV12B	FC/MC/PC43C	0.98	0.98	1.03
MV16C	FC/MC/PC43C	0.99	0.99	1.01
MV12D	FC/MC/PC48D	0.98	0.98	1.00
MV12D	UC48D	0.98	0.98	1.00
MV16C	FC/MC/PC48C	0.99	0.99	1.00
MV16C	FC/MC/PC48D	0.99	0.99	1.00
MV16C	UC48D	0.99	0.99	1.00
MV20D	FC/MC/PC48D	1.00	1.00	1.00
MV20D	UC48D	1.00	1.00	1.00
MV12D	FC/MC62D	1.00	1.00	1.00
MV20D	FC/MC62D	1.01	1.01	1.00

Continued on next page.

Furnaces	Coils	T.C.	S.C.	KW
T*(8,L)X*B12	FC/MC/PC35B	0.96	0.98	1.09
T*(8,L)X*C16	FC/MC/PC35C	0.96	0.94	1.03
T*(8,L)X*C20	FC/MC/PC35C	0.96	0.97	1.03
T*9X*B12	FC/MC/PC35B	0.96	0.97	1.07
T*9X*C16	FC/MC/PC35C	0.97	0.98	1.06
T*9X*C20	FC/MC/PC35C	0.97	0.97	1.09
T*(8,L)X*A12	FC/MC/PC36A	0.95	0.93	1.08
T*(8,L)X*B12	FC/MC/PC36B	0.95	0.95	1.06
T*(8,L)X*C16	FC/MC/PC36C	0.95	0.92	1.02
T*(8,L)X*C20	FC/MC/PC36C	0.96	0.96	1.05
T*9X*B12	FC/MC/PC36B	0.95	0.94	1.06
T*9X*C16	FC/MC/PC36C	0.95	0.96	1.06
T*9X*C20	FC/MC/PC36C	0.96	0.95	1.07
T*(8,L)X*A12	FC/MC/PC37A	0.93	0.95	1.02
T*(8,L)X*B12	FC/MC/PC42B	0.95	0.94	1.04
T*(8,L)X*C16	FC/MC/PC42C	0.97	0.98	1.02
T*(8,L)X*C20	FC/MC/PC42C	0.96	0.97	1.03
T*9X*B12	FC/MC/PC42B	0.95	0.97	1.08
T*9X*C16	FC/MC/PC42C	0.95	0.96	1.04
T*(8,L)X*B12	FC/MC/PC43B	0.97	0.99	1.08
T*(8,L)X*C16	FC/MC/PC43C	0.98	0.98	1.01
T*(8,L)X*C20	FC/MC/PC43C	0.98	1.00	1.03
T*9X*B12	FC/MC/PC43B	0.97	1.00	1.08
T*9X*C16	FC/MC/PC43C	0.97	0.98	1.07
T*9X*C20	FC/MC/PC43C	0.98	0.98	1.05
T*(8,L)X*C16	FC/MC/PC48C	0.99	1.00	1.03
T*(8,L)X*C20	FC/MC/PC48C	0.99	1.01	1.03
T*9X*C16	FC/MC/PC48C	0.99	1.02	1.06
T*9X*C20	FC/MC/PC48C	1.00	1.01	1.08
T*9X*D20	FC/MC/PC48D	1.01	1.01	1.04
T*9X*D20	FC/MC62D	1.01	1.01	1.04
T*9X*D20	HD48	1.00	1.02	1.06
T*(8,L)X*A12	UC36A	0.93	0.93	1.08
T*(8,L)X*B12	UC36B	0.93	0.93	1.07
T*(8,L)X*C16	UC36C	0.94	0.91	1.03
T*(8,L)X*C20	UC36C	0.94	0.94	1.03
T*9X*C20	UC36C	0.95	0.94	1.06
T*(8,L)X*B12	UC42B	0.95	0.93	1.04
T*(8,L)X*C16	UC42C	0.96	0.96	1.03
T*(8,L)X*C20	UC42C	0.96	0.96	1.03
T*9X*B12	UC42B	0.95	0.95	1.08
T*9X*C16	UC42C	0.95	0.96	1.04
T*(8,L)X*C16	UC48C	0.97	0.99	1.03
T*(8,L)X*C20	UC48C	0.97	0.99	1.02
T*9X*C16	UC48C	0.97	1.00	1.07
T*9X*C20	UC48C	0.98	0.99	1.07
T*9X*D20	UC48D	0.98	1.01	1.06
(C*(8,L)C/T*8V)*B12	FC/MC/PC35B	0.97	0.96	1.07
(C*9C/T*9V)*B12	FC/MC/PC35B	0.97	0.97	1.07
(C*(8,L)C/T*8V)*C16	FC/MC/PC35C	0.98	0.97	1.04
(C*(8,L)C/T*8V)*C20	FC/MC/PC35C	0.97	0.96	1.02
(C*9C/T*9V)*C16	FC/MC/PC35C	0.98	0.97	1.04

Furnaces	Coils	T.C.	S.C.	KW
(C*9C/T*9V)*C20	FC/MC/PC35C	0.98	1.00	1.07
(C*(8,L)C/T*8V)*A12	FC/MC/PC36A	0.95	0.94	1.07
(C*(8,L)C/T*8V)*B12	FC/MC/PC36B	0.96	0.96	1.05
(C*9C/T*9V)*B12	FC/MC/PC36B	0.96	0.94	1.05
(C*(8,L)C/T*8V)*C16	FC/MC/PC36C	0.96	0.95	1.03
(C*(8,L)C/T*8V)*C20	FC/MC/PC36C	0.96	0.95	1.02
(C*9C/T*9V)*C16	FC/MC/PC36C	0.96	0.95	1.03
(C*9C/T*9V)*C20	FC/MC/PC36C	0.97	0.99	1.06
(C*(8,L)C/T*8V)*A12	FC/MC/PC37A	0.95	0.90	1.03
(C*(8,L)C/T*8V)*B12	FC/MC/PC42B	0.96	0.95	1.03
(C*9C/T*9V)*B12	FC/MC/PC42B	0.96	0.96	1.07
(C*(8,L)C/T*8V)*C16	FC/MC/PC42C	0.98	0.98	1.01
(C*(8,L)C/T*8V)*C20	FC/MC/PC42C	0.97	0.96	1.00
(C*9C/T*9V)*C16	FC/MC/PC42C	0.96	0.96	1.03
(C*9C/T*9V)*C20	FC/MC/PC42C	0.98	1.01	1.05
(C*(8,L)C/T*8V)*B12	FC/MC/PC43B	0.98	0.98	1.07
(C*9C/T*9V)*B12	FC/MC/PC43B	0.98	0.98	1.07
(C*(8,L)C/T*8V)*C16	FC/MC/PC43C	0.98	0.99	1.03
(C*(8,L)C/T*8V)*C20	FC/MC/PC43C	0.98	0.99	1.02
(C*9C/T*9V)*C16	FC/MC/PC43C	0.98	0.99	1.06
(C*9C/T*9V)*C20	FC/MC/PC43C	0.98	0.99	1.03
(C*(8,L)C/T*8V)*C16	FC/MC/PC48C	0.98	0.99	1.02
(C*(8,L)C/T*8V)*C20	FC/MC/PC48C	0.98	0.98	1.01
(C*9C/T*9V)*C16	FC/MC/PC48C	0.98	0.99	1.04
(C*9C/T*9V)*C20	FC/MC/PC48C	0.98	1.02	1.06
(C*(8,L)C/T*8V)*C16	HC42	0.98	0.98	1.03
(C*(8,L)C/T*8V)*C20	HC42	0.98	0.98	1.02
(C*9C/T*9V)*C16	HC42	0.98	0.98	1.06
(C*9C/T*9V)*C20	HC42	0.98	0.98	1.04
(C*(8,L)C/T*8V)*B12	HD48	0.98	0.98	1.05
(C*(8,L)C/T*8V)*C16	HD48	0.98	0.98	1.02
(C*(8,L)C/T*8V)*C20	HD48	0.98	0.97	1.01
(C*9C/T*9V)*B12	HD48	0.98	0.96	1.06
(C*9C/T*9V)*C16	HD48	0.98	0.98	1.03
(C*9C/T*9V)*C20	HD48	0.98	1.01	1.06
(C*(8,L)C/T*8V)*A12	UC36A	0.94	0.92	1.07
(C*(8,L)C/T*8V)*B12	UC36B	0.95	0.94	1.05
(C*9C/T*9V)*B12	UC36B	0.95	0.93	1.04
(C*(8,L)C/T*8V)*C16	UC36C	0.95	0.93	1.03
(C*(8,L)C/T*8V)*C20	UC36C	0.95	0.93	1.02
(C*9C/T*9V)*C16	UC36C	0.95	0.93	1.03
(C*9C/T*9V)*C20	UC36C	0.96	0.98	1.06
(C*(8,L)C/T*8V)*B12	UC42B	0.96	0.95	1.03
(C*9C/T*9V)*B12	UC42B	0.95	0.95	1.07
(C*(8,L)C/T*8V)*C16	UC42C	0.97	0.96	1.01
(C*(8,L)C/T*8V)*C20	UC42C	0.97	0.95	1.00
(C*9C/T*9V)*C16	UC42C	0.96	0.95	1.03
(C*9C/T*9V)*C20	UC42C	0.98	0.99	1.05
(C*(8,L)C/T*8V)*C16	UC48C	0.98	0.99	1.02
(C*(8,L)C/T*8V)*C20	UC48C	0.98	0.98	1.01
(C*9C/T*9V)*C16	UC48C	0.98	0.99	1.03
(C*9C/T*9V)*C20	UC48C	0.98	1.02	1.06

COOLING PERFORMANCE DATA - LOW CFM 1-STAGE OPERATION																
OUTDOOR UNIT MODEL NO.		AC8B048F3(C)														
INDOOR COIL MODEL NO.		FC62D + MV20D														
CONDENSER ENTERING AIR TEMPERATURE	ID CFM	950					1000					1050				
	ID DB (°F)	80	80	75	80	80	80	80	75	80	80	80	80	75	80	80
	ID WB (°F)	57	62	62	67	72	57	62	62	67	72	57	62	62	67	72
65	T.C.	35.4	36.6	36.2	39.8	42.3	36.1	37.2	36.8	40.2	42.9	36.8	37.8	37.4	40.6	43.4
	S.C.	34.3	31.8	26.9	27.2	21.7	34.8	32.5	27.6	27.8	22.0	35.3	33.3	28.2	28.5	22.3
	K.W.	1.50	1.50	1.49	1.48	1.48	1.50	1.49	1.49	1.48	1.47	1.49	1.49	1.49	1.47	1.47
75	T.C.	34.0	34.9	34.5	37.8	40.4	34.6	35.4	35.0	38.2	40.9	35.2	36.0	35.5	38.6	41.5
	S.C.	32.9	31.0	26.2	26.4	21.0	33.4	31.7	26.8	27.0	21.3	33.9	32.4	27.4	27.6	21.7
	K.W.	1.81	1.81	1.81	1.80	1.79	1.81	1.81	1.80	1.79	1.78	1.80	1.80	1.80	1.79	1.78
85	T.C.	32.5	33.1	32.8	35.7	38.5	33.1	33.7	33.2	36.2	39.0	33.7	34.2	33.6	36.6	39.5
	S.C.	31.5	30.2	25.5	25.5	20.3	32.0	30.9	26.0	26.1	20.7	32.5	31.6	26.6	26.7	21.1
	K.W.	2.12	2.12	2.12	2.11	2.10	2.12	2.12	2.12	2.11	2.10	2.12	2.12	2.11	2.11	2.09
95	T.C.	31.1	31.4	31.1	33.7	36.6	31.7	31.9	31.4	34.2	37.1	32.2	32.4	31.7	34.6	37.6
	S.C.	30.1	29.4	24.8	24.7	19.6	30.6	30.1	25.3	25.3	20.0	31.1	30.8	25.8	25.8	20.4
	K.W.	2.44	2.44	2.44	2.43	2.41	2.43	2.43	2.43	2.43	2.41	2.43	2.43	2.43	2.42	2.40
105	T.C.	29.4	29.7	28.9	31.5	34.2	30.0	30.2	29.3	31.9	34.6	30.5	30.7	29.6	32.3	35.0
	S.C.	28.5	27.8	23.8	23.8	18.7	28.9	28.5	24.3	24.4	19.1	29.4	29.1	24.8	24.9	19.6
	K.W.	2.86	2.87	2.87	2.87	2.84	2.86	2.86	2.86	2.86	2.84	2.86	2.86	2.86	2.85	2.84
115	T.C.	27.8	28.0	26.9	29.3	31.9	28.4	28.6	27.2	29.7	32.2	28.9	29.1	27.6	30.1	32.5
	S.C.	26.9	26.3	22.9	23.0	17.8	27.4	26.9	23.4	23.5	18.3	27.8	27.5	23.9	24.1	18.7
	K.W.	3.28	3.28	3.29	3.29	3.26	3.27	3.28	3.28	3.27	3.26	3.27	3.27	3.28	3.27	3.26
125	T.C.	26.2	26.4	24.8	27.1	29.6	26.7	26.9	25.2	27.5	29.8	27.2	27.5	25.6	27.9	30.0
	S.C.	25.4	24.8	21.9	22.1	16.9	25.8	25.4	22.4	22.7	17.4	26.2	26.0	22.9	23.3	17.9
	K.W.	3.69	3.70	3.71	3.71	3.67	3.69	3.69	3.70	3.69	3.67	3.69	3.69	3.70	3.68	3.68

NOTE: ALL CAPACITIES ARE NET (KBTUH) WITH INDOOR FAN HEAT ALREADY DEDUCTED AT 1250 BTUH/1000 CFM.

Multipliers for determining the performance with other indoor sections.

NOTE: For dry bulb temperatures different than those listed (between 73-87 F), sensible capacity increases by 1060 BTUH per 1000 CFM per degree above the listed temperature and decreases by 1060 BTUH per 1000 CFM per degree below the listed temperature.

NOTE: KW RATING IS FOR OUTDOOR AND INDOOR UNITS.

LOW CFM

Air Handlers	Coils	T.C.	S.C.	KW
AV/SV*48	–	0.97	0.97	1.05
AV/SV*60	–	0.96	0.94	1.03
AHX48	–	0.97	0.98	1.05
AHX60	–	0.96	0.95	1.03
F4FV060	–	0.99	0.98	1.01
MV16C	FC/MC/PC48C	1.00	1.00	0.99
MV16C	FC/MC/PC48D	1.00	1.00	0.99
MV16C	UC48D	1.00	1.00	0.99
MV20D	FC/MC/PC48D	1.00	1.00	1.00
MV20D	UC48D	1.00	1.00	1.00
MV20D	FC/MC62D	1.00	1.00	1.00

Continued on next page.

Furnaces	Coils	T.C.	S.C.	KW
T*(8,L)X*C16	FC/MC/PC48C	0.98	0.99	1.06
T*(8,L)X*C20	FC/MC/PC48C	0.93	0.89	1.03
T*9X*C20	FC/MC/PC48C	0.98	1.01	1.06
T*9X*D20	FC/MC/PC48D	0.97	1.01	1.03
T*(8,L)X*C16	FC/PC60C	0.96	0.97	1.03
T*(8,L)X*C20	FC/PC60C	0.92	0.88	1.01
T*(8,L)X*C20	FC/MC/PC60D	0.92	0.88	1.01
T*9X*C20	FC/PC60C	0.92	1.02	1.00
T*9X*D20	FC/MC/PC60D	0.95	1.00	1.01
T*(8,L)X*C16	FC/MC62D	0.99	0.99	1.05
T*(8,L)X*C20	FC/MC62D	0.93	0.88	1.02
T*9X*C20	FC/MC62D	1.00	1.03	1.06
T*9X*D20	FC/MC62D	0.97	1.00	1.03
T*(8,L)X*C16	HD48	0.96	0.98	1.02
T*9X*C20	HD48	0.97	1.01	1.05
T*(8,L)X*C16	UC48C	0.90	0.90	1.07
T*9X*C20	UC48C	0.91	0.92	1.07
T*9X*D20	UC48D	0.87	0.88	1.02
T*(8,L)X*C16	UC60C	0.88	0.88	1.03
T*(8,L)X*C20	UC60C	0.86	0.81	1.02
T*(8,L)X*C20	UC60D	0.86	0.81	1.02
T*9X*D20	UC60D	0.88	0.90	1.03
(C*(8,L)C/T*8V)*C16	FC/MC/PC48C	1.00	0.99	1.02
(C*(8,L)C/T*8V)*C20	FC/MC/PC48C	1.00	0.99	1.02
(C*9C/T*9V)*C16	FC/MC/PC48C	1.00	1.00	1.02
(C*9C/T*9V)*C20	FC/MC/PC48C	1.00	1.00	1.02
(C*9C/T*9V)*D20	FC/MC/PC48D	0.99	0.98	1.02

Furnaces	Coils	T.C.	S.C.	KW
(C*9C/T*9V)*D20	FC/MC/PC60D	0.97	0.96	1.02
(C*9C/T*9V)*D20	FC/MC62D	0.99	0.99	1.02
(C*(8,L)C/T*8V)*C16	FC/PC60C	0.98	0.97	1.01
(C*(8,L)C/T*8V)*C20	FC/PC60C	0.98	0.97	1.01
(C*9C/T*9V)*C16	FC/PC60C	0.97	0.96	1.02
(C*9C/T*9V)*C20	FC/PC60C	0.98	0.97	1.02
(C*9C/T*9V)*D20	HC60	0.96	0.96	1.03
(C*(8,L)C/T*8V)*C16	HD48	0.98	0.97	1.02
(C*(8,L)C/T*8V)*C20	HD48	0.98	0.97	1.02
(C*9C/T*9V)*C16	HD48	0.99	0.97	1.02
(C*9C/T*9V)*C20	HD48	0.99	0.97	1.02
(C*9C/T*9V)*D20	HD48	0.98	0.97	1.02
(C*(8,L)C/T*8V)*C16	HD60	1.01	1.00	1.01
(C*(8,L)C/T*8V)*C20	HD60	1.01	1.00	1.00
(C*9C/T*9V)*C16	HD60	1.00	1.00	1.02
(C*9C/T*9V)*C20	HD60	1.01	1.00	1.02
(C*9C/T*9V)*D20	HD60	1.00	1.00	1.02
(C*(8,L)C/T*8V)*C16	UC48C	0.95	0.95	1.02
(C*(8,L)C/T*8V)*C20	UC48C	0.95	0.95	1.03
(C*9C/T*9V)*C16	UC48C	0.95	0.96	1.03
(C*9C/T*9V)*C20	UC48C	0.95	0.97	1.02
(C*9C/T*9V)*D20	UC48D	0.89	0.90	1.03
(C*(8,L)C/T*8V)*C16	UC60C	0.90	0.87	1.02
(C*(8,L)C/T*8V)*C20	UC60C	0.90	0.87	1.01
(C*9C/T*9V)*C16	UC60C	0.90	0.87	1.03
(C*9C/T*9V)*C20	UC60C	0.90	0.87	1.03
(C*9C/T*9V)*D20	UC60D	0.90	0.87	1.03

COOLING PERFORMANCE DATA - HIGH CFM 2-STAGE OPERATION																
OUTDOOR UNIT MODEL NO.		AC8B048F3(C)														
INDOOR COIL MODEL NO.		FC62D + MV20D														
CONDENSER ENTERING AIR TEMPERATURE	ID CFM	1500					1600					1700				
	ID DB (°F)	80	80	75	80	80	80	80	75	80	80	80	80	75	80	80
	ID WB (°F)	57	62	62	67	72	57	62	62	67	72	57	62	62	67	72
65	T.C.	48.7	49.9	49.0	53.2	56.4	49.6	50.4	49.5	54.4	56.8	50.5	50.9	50.0	55.5	57.2
	S.C.	48.0	44.9	38.2	37.9	29.7	48.9	46.3	39.1	39.0	30.3	49.7	47.6	40.0	40.1	30.9
	K.W.	2.53	2.57	2.56	2.64	2.71	2.58	2.61	2.61	2.67	2.75	2.64	2.67	2.66	2.72	2.79
75	T.C.	46.8	47.7	46.8	50.9	53.6	47.6	48.2	47.2	51.8	54.0	48.3	48.8	47.6	52.5	54.4
	S.C.	46.2	43.8	37.1	36.8	28.7	46.9	45.0	38.0	37.9	29.3	47.6	46.2	38.9	38.9	29.9
	K.W.	2.89	2.91	2.90	2.98	3.05	2.93	2.96	2.95	3.02	3.09	2.99	3.01	3.00	3.07	3.15
85	T.C.	45.0	45.5	44.5	48.6	50.9	45.6	46.1	44.9	49.1	51.3	46.2	46.6	45.2	49.6	51.6
	S.C.	44.3	42.6	35.9	35.7	27.8	44.9	43.7	36.9	36.7	28.4	45.6	44.8	37.8	37.7	28.9
	K.W.	3.24	3.26	3.25	3.33	3.40	3.29	3.31	3.29	3.37	3.44	3.34	3.36	3.34	3.42	3.50
95	T.C.	43.1	43.4	42.2	46.3	48.2	43.5	43.9	42.5	46.5	48.5	44.0	44.4	42.9	46.6	48.8
	S.C.	42.4	41.5	34.8	34.6	26.9	43.0	42.4	35.7	35.6	27.4	43.5	43.3	36.7	36.5	27.9
	K.W.	3.59	3.61	3.60	3.68	3.75	3.64	3.66	3.64	3.72	3.79	3.69	3.71	3.69	3.77	3.85
105	T.C.	40.7	41.0	39.6	43.5	45.2	41.2	41.5	39.9	43.7	45.4	41.6	41.9	40.1	43.9	45.6
	S.C.	40.1	39.3	33.5	33.5	25.8	40.6	40.1	34.4	34.4	26.3	41.1	40.8	35.4	35.3	26.8
	K.W.	4.10	4.12	4.10	4.18	4.25	4.15	4.16	4.14	4.22	4.29	4.21	4.22	4.19	4.27	4.35
115	T.C.	38.5	38.7	37.2	40.7	42.4	38.9	39.1	37.3	40.9	42.5	39.3	39.5	37.4	41.2	42.5
	S.C.	37.9	37.2	32.3	32.4	24.9	38.4	37.8	33.2	33.3	25.3	38.8	38.4	34.1	34.2	25.7
	K.W.	4.60	4.60	4.58	4.67	4.74	4.65	4.65	4.62	4.71	4.78	4.70	4.71	4.67	4.76	4.83
125	T.C.	36.2	36.4	34.7	37.9	39.6	36.6	36.8	34.7	38.2	39.6	36.9	37.1	34.7	38.4	39.5
	S.C.	35.7	35.1	31.1	31.3	23.9	36.1	35.6	32.0	32.2	24.3	36.5	36.0	32.8	33.1	24.6
	K.W.	5.09	5.09	5.07	5.16	5.23	5.14	5.14	5.11	5.20	5.27	5.20	5.21	5.16	5.25	5.32

NOTE: ALL CAPACITIES ARE NET (KBTUH) WITH INDOOR FAN HEAT ALREADY DEDUCTED AT 1250 BTUH/1000 CFM.

Multipliers for determining the performance with other indoor sections

NOTE: For dry bulb temperatures different than those listed (between 73-87 F), sensible capacity increases by 1060 BTUH per 1000 CFM per degree above the listed temperature and decreases by 1060 BTUH per 1000 CFM per degree below the listed temperature.

NOTE: KW RATING IS FOR OUTDOOR AND INDOOR UNITS.

HIGH CFM

Air Handlers	Coils	T.C.	S.C.	KW
AV/SV*48	–	0.97	0.96	1.03
AV/SV*60	–	0.97	0.95	1.03
AHX48	–	0.97	0.97	1.03
AHX60	–	0.97	0.97	1.03
F4FV060	–	0.96	0.96	0.98
MV16C	FC/MC/PC48C	0.99	0.99	0.99
MV16C	FC/MC/PC48D	0.99	0.99	0.99
MV16C	UC48D	0.99	0.99	0.99
MV20D	FC/MC/PC48D	0.99	0.99	1.00
MV20D	UC48D	0.99	0.99	1.00
MV20D	FC/MC62D	1.00	1.00	1.00

Continued on next page.

Furnaces	Coils	T.C.	S.C.	KW
T*(8,L)X*C16	FC/MC/PC48C	0.98	0.97	1.06
T*(8,L)X*C20	FC/MC/PC48C	0.98	0.99	1.04
T*9X*C20	FC/MC/PC48C	0.98	0.97	1.04
T*9X*D20	FC/MC/PC48D	0.97	0.96	1.05
T*(8,L)X*C16	FC/PC60C	0.96	0.94	1.04
T*(8,L)X*C20	FC/PC60C	0.97	0.95	1.03
T*(8,L)X*C20	FC/MC/PC60D	0.97	0.95	1.03
T*9X*C20	FC/PC60C	0.94	0.97	1.06
T*9X*D20	FC/MC/PC60D	0.96	0.93	1.02
T*(8,L)X*C16	FC/MC62D	0.98	0.97	1.04
T*(8,L)X*C20	FC/MC62D	0.99	0.99	1.03
T*9X*C20	FC/MC62D	0.98	0.97	1.04
T*9X*D20	FC/MC62D	0.97	0.96	1.05
T*(8,L)X*C16	HD48	0.98	0.97	1.06
T*9X*C20	HD48	0.97	0.97	1.03
T*(8,L)X*C16	UC48C	0.91	0.89	1.04
T*9X*C20	UC48C	0.92	0.91	1.05
T*9X*D20	UC48D	0.90	0.89	1.03
T*(8,L)X*C16	UC60C	0.90	0.88	1.03
T*(8,L)X*C20	UC60C	0.92	0.91	1.01
T*(8,L)X*C20	UC60D	0.92	0.91	1.01
T*9X*D20	UC60D	0.90	0.88	1.03
(C*(8,L)C/T*8V)*C16	FC/MC/PC48C	1.00	1.00	1.04
(C*(8,L)C/T*8V)*C20	FC/MC/PC48C	1.00	1.00	1.04
(C*9C/T*9V)*C16	FC/MC/PC48C	1.00	0.99	1.04
(C*9C/T*9V)*C20	FC/MC/PC48C	1.00	0.99	1.04
(C*9C/T*9V)*D20	FC/MC/PC48D	0.99	0.98	1.04

Furnaces	Coils	T.C.	S.C.	KW
(C*9C/T*9V)*D20	FC/MC/PC60D	0.98	0.98	1.03
(C*9C/T*9V)*D20	FC/MC62D	0.99	0.98	1.03
(C*(8,L)C/T*8V)*C16	FC/PC60C	0.98	0.98	1.03
(C*(8,L)C/T*8V)*C20	FC/PC60C	0.99	0.98	1.01
(C*9C/T*9V)*C16	FC/PC60C	0.98	0.98	1.04
(C*9C/T*9V)*C20	FC/PC60C	0.98	0.98	1.04
(C*9C/T*9V)*D20	HC60	0.97	0.97	1.03
(C*(8,L)C/T*8V)*C16	HD48	1.00	0.98	1.03
(C*(8,L)C/T*8V)*C20	HD48	1.00	0.98	1.04
(C*9C/T*9V)*C16	HD48	0.99	0.97	1.04
(C*9C/T*9V)*C20	HD48	0.99	0.97	1.04
(C*9C/T*9V)*D20	HD48	1.00	0.97	1.04
(C*(8,L)C/T*8V)*C16	HD60	1.00	1.00	1.03
(C*(8,L)C/T*8V)*C20	HD60	1.00	1.01	1.01
(C*9C/T*9V)*C16	HD60	1.00	1.00	1.04
(C*9C/T*9V)*C20	HD60	1.00	1.00	1.04
(C*9C/T*9V)*D20	HD60	1.00	1.00	1.04
(C*(8,L)C/T*8V)*C16	UC48C	0.97	0.97	1.03
(C*(8,L)C/T*8V)*C20	UC48C	0.96	0.96	1.03
(C*9C/T*9V)*C16	UC48C	0.96	0.96	1.03
(C*9C/T*9V)*C20	UC48C	0.96	0.96	1.04
(C*9C/T*9V)*D20	UC48D	0.92	0.90	1.03
(C*(8,L)C/T*8V)*C16	UC60C	0.93	0.90	1.02
(C*(8,L)C/T*8V)*C20	UC60C	0.93	0.91	1.00
(C*9C/T*9V)*C16	UC60C	0.92	0.90	1.03
(C*9C/T*9V)*C20	UC60C	0.92	0.90	1.03
(C*9C/T*9V)*D20	UC60D	0.93	0.90	1.02

COOLING PERFORMANCE DATA - LOW CFM 1-STAGE OPERATION																
OUTDOOR UNIT MODEL NO.		AC8B060F3(C)														
INDOOR COIL MODEL NO.		FC62D + MV20D														
CONDENSER ENTERING AIR TEMPERATURE	ID CFM	1100					1150					1200				
	ID DB (°F)	80	80	75	80	80	80	80	75	80	80	80	80	75	80	80
	ID WB (°F)	57	62	62	67	72	57	62	62	67	72	57	62	62	67	72
65	T.C.	38.1	44.0	43.9	47.7	52.4	39.7	44.2	44.3	48.1	53.0	41.4	44.3	44.7	48.5	53.5
	S.C.	37.2	35.7	30.6	30.0	24.5	38.8	36.5	31.2	30.6	24.9	40.4	37.3	31.7	31.2	25.3
	K.W.	3.20	1.94	1.94	1.91	1.92	2.79	1.94	1.94	1.91	1.90	2.37	1.95	1.94	1.92	1.88
75	T.C.	37.5	42.0	42.0	45.7	50.2	39.2	42.4	42.3	46.1	50.8	40.8	42.8	42.7	46.5	51.3
	S.C.	36.6	35.0	29.8	29.4	23.8	38.2	35.8	30.4	30.0	24.2	39.8	36.6	30.9	30.6	24.6
	K.W.	3.20	2.36	2.36	2.33	2.34	2.78	2.36	2.36	2.34	2.32	2.37	2.37	2.36	2.35	2.31
85	T.C.	37.0	40.1	40.0	43.8	48.1	38.6	40.7	40.4	44.2	48.6	40.2	41.3	40.7	44.5	49.1
	S.C.	36.1	34.2	29.0	28.7	23.1	37.7	35.0	29.6	29.3	23.5	39.2	35.8	30.1	29.9	23.8
	K.W.	3.20	2.78	2.78	2.75	2.76	2.78	2.78	2.78	2.76	2.75	2.37	2.78	2.78	2.77	2.74
95	T.C.	36.5	38.2	38.1	41.9	45.9	38.1	39.0	38.4	42.2	46.4	39.7	39.8	38.7	42.5	46.9
	S.C.	35.6	33.5	28.2	28.1	22.4	37.1	34.3	28.8	28.7	22.7	38.7	35.0	29.3	29.2	23.1
	K.W.	3.20	3.19	3.20	3.17	3.17	2.78	3.20	3.20	3.18	3.17	2.37	3.20	3.20	3.19	3.17
105	T.C.	34.2	35.5	35.3	38.8	42.7	35.4	36.1	35.6	39.1	43.1	36.6	36.7	35.8	39.3	43.5
	S.C.	33.4	31.9	26.7	26.8	21.0	34.6	32.6	27.3	27.3	21.4	35.7	33.2	27.8	27.8	21.8
	K.W.	3.76	3.75	3.75	3.73	3.73	3.48	3.75	3.75	3.74	3.73	3.20	3.76	3.76	3.75	3.74
115	T.C.	32.0	32.9	32.6	35.8	39.7	32.8	33.3	32.9	36.0	39.9	33.5	33.7	33.1	36.3	40.2
	S.C.	31.3	30.4	25.3	25.4	19.7	32.0	30.9	25.9	25.9	20.1	32.8	31.5	26.4	26.4	20.5
	K.W.	4.30	4.29	4.29	4.28	4.28	4.16	4.29	4.29	4.28	4.28	4.02	4.29	4.29	4.29	4.28
125	T.C.	29.9	30.3	30.0	32.7	36.6	30.2	30.5	30.1	33.0	36.7	30.5	30.6	30.3	33.2	36.9
	S.C.	29.2	28.9	23.9	24.1	18.3	29.5	29.3	24.4	24.5	18.8	29.8	29.7	24.9	24.9	19.3
	K.W.	4.84	4.82	4.83	4.83	4.83	4.83	4.83	4.83	4.83	4.83	4.83	4.83	4.83	4.83	4.83

NOTE: ALL CAPACITIES ARE NET (KBTUH) WITH INDOOR FAN HEAT ALREADY DEDUCTED AT 1250 BTUH/1000 CFM.

Multipliers for determining the performance with other indoor sections.

NOTE: For dry bulb temperatures different than those listed (between 73-87 F), sensible capacity increases by 1060 BTUH per 1000 CFM per degree above the listed temperature and decreases by 1060 BTUH per 1000 CFM per degree below the listed temperature.

NOTE: KW RATING IS FOR OUTDOOR AND INDOOR UNITS.

LOW CFM

Air Handlers	Coils	T.C.	S.C.	KW
AV/SV*60	-	0.99	0.96	1.04
AHX60	-	0.99	0.96	1.04
F4FV060	-	0.99	0.99	1.02
MV20D	FC/MC/PC60D	0.95	0.95	1.00
MV20D	UC60D	0.95	0.95	1.00
MV20D	FC/MC62D	1.00	1.00	1.00

Furnaces	Coils	T.C.	S.C.	KW
T*(8,L)X*C16	FC/PC60C	0.97	0.96	1.03
T*(8,L)X*C20	FC/PC60C	0.93	0.87	1.02
T*(8,L)X*C20	FC/MC/PC60D	0.93	0.87	1.02
T*9X*C20	FC/PC60C	0.95	0.98	1.03
T*9X*D20	FC/MC/PC60D	1.00	1.03	1.04
T*9X*C20	FC/MC/PC60D	1.00	1.02	1.04
T*(8,L)X*C20	FC/MC62D	0.91	0.86	1.01
T*9X*C20	FC/MC62D	1.00	1.01	1.04
T*9X*D20	FC/MC62D	0.96	0.97	1.02

Furnaces	Coils	T.C.	S.C.	KW
T*9X*D20	HD60	0.96	0.96	1.02
T*(8,L)X*C16	UC60C	0.94	0.93	1.04
T*(8,L)X*C20	UC60C	0.90	0.83	1.02
T*(8,L)X*C20	UC60D	0.90	0.83	1.02
T*9X*D20	UC60D	0.91	0.93	1.03
T*9X*C20	UC60C	0.97	0.98	1.05
T*9X*C20	UC60D	0.97	0.98	1.05
(C*9C/T*9V)*D20	FC/MC62D	0.98	0.97	1.03
(C*(8,L)C/T*8V)*C20	FC/PC60C	0.97	0.95	1.01
(C*9C/T*9V)*C20	FC/PC60C	0.97	0.95	1.02
(C*9C/T*9V)*D20	HC60	0.95	0.94	1.02
(C*(8,L)C/T*8V)*C20	HD60	0.98	0.95	1.01
(C*9C/T*9V)*C20	HD60	0.98	0.97	1.03
(C*9C/T*9V)*D20	HD60	0.99	0.97	1.03
(C*(8,L)C/T*8V)*C20	UC60C	0.94	0.91	1.01
(C*9C/T*9V)*C20	UC60C	0.93	0.90	1.02
(C*9C/T*9V)*D20	UC60D	0.94	0.92	1.02

COOLING PERFORMANCE DATA - HIGH CFM 2-STAGE OPERATION																
OUTDOOR UNIT MODEL NO.		AC8B060F3(C)														
INDOOR COIL MODEL NO.		FC62D + MV20D														
CONDENSER ENTERING AIR TEMPERATURE	ID CFM	1750					1850					1950				
	ID DB (°F)	80	80	75	80	80	80	80	75	80	80	80	80	75	80	80
	ID WB (°F)	57	62	62	67	72	57	62	62	67	72	57	62	62	67	72
65	T.C.	57.1	61.0	60.6	66.2	71.1	58.0	61.4	61.2	66.8	72.2	58.8	61.6	61.8	67.3	73.3
	S.C.	58.1	53.7	44.6	44.7	36.4	59.0	54.7	46.2	45.8	36.6	59.8	55.6	47.7	46.8	36.8
	K.W.	3.20	3.25	3.26	3.32	3.36	3.27	3.32	3.31	3.39	3.44	3.36	3.40	3.38	3.47	3.53
75	T.C.	55.3	58.5	58.0	63.4	68.2	56.0	58.8	58.4	63.9	68.9	56.7	59.1	58.7	64.3	69.5
	S.C.	56.3	52.5	43.9	43.6	34.8	57.0	53.5	44.9	44.6	34.9	57.7	54.5	45.8	45.6	34.9
	K.W.	3.69	3.74	3.74	3.80	3.86	3.77	3.80	3.79	3.87	3.93	3.85	3.88	3.86	3.95	4.01
85	T.C.	53.6	55.9	55.4	60.6	65.3	54.1	56.2	55.5	60.9	65.5	54.6	56.5	55.6	61.2	65.8
	S.C.	54.5	51.3	43.2	42.5	33.1	55.1	52.4	43.6	43.5	33.1	55.6	53.4	44.0	44.4	33.0
	K.W.	4.19	4.23	4.22	4.29	4.35	4.26	4.29	4.28	4.35	4.41	4.34	4.36	4.35	4.43	4.49
95	T.C.	51.8	53.3	52.8	57.8	62.4	52.2	53.6	52.7	58.0	62.2	52.6	53.9	52.5	58.2	62.0
	S.C.	52.7	50.1	42.5	41.5	31.5	53.1	51.3	42.4	42.3	31.4	53.5	52.4	42.1	43.2	31.2
	K.W.	4.69	4.71	4.70	4.77	4.84	4.76	4.77	4.76	4.83	4.90	4.83	4.85	4.83	4.91	4.97
105	T.C.	48.6	49.8	49.3	53.9	58.3	49.1	50.1	49.3	54.1	58.2	49.5	50.4	49.2	54.2	58.1
	S.C.	49.5	47.7	40.5	39.8	30.1	50.0	48.7	40.7	40.6	30.1	50.4	49.6	40.8	41.3	30.1
	K.W.	5.39	5.40	5.38	5.46	5.54	5.46	5.47	5.44	5.53	5.60	5.54	5.55	5.52	5.60	5.67
115	T.C.	45.6	46.3	46.0	50.2	54.3	46.1	46.7	46.0	50.3	54.3	46.5	47.1	46.0	50.4	54.2
	S.C.	46.4	45.4	38.6	38.2	28.7	46.9	46.2	39.0	38.9	29.0	47.4	46.9	39.4	39.6	29.1
	K.W.	6.06	6.07	6.04	6.13	6.22	6.14	6.14	6.11	6.20	6.28	6.23	6.22	6.19	6.28	6.36
125	T.C.	42.6	42.8	42.6	46.4	50.3	43.1	43.3	42.7	46.5	50.4	43.5	43.7	42.7	46.5	50.4
	S.C.	43.4	43.2	36.6	36.6	27.4	43.9	43.7	37.4	37.2	27.8	44.3	44.1	38.1	37.8	28.2
	K.W.	6.74	6.75	6.71	6.80	6.89	6.82	6.82	6.78	6.87	6.96	6.91	6.90	6.86	6.96	7.04

NOTE: ALL CAPACITIES ARE NET (KBTUH) WITH INDOOR FAN HEAT ALREADY DEDUCTED AT 1250 BTUH/1000 CFM.

Multipliers for determining the performance with other indoor sections.

NOTE: For dry bulb temperatures different than those listed (between 73-87 F), sensible capacity increases by 1060 BTUH per 1000 CFM per degree above the listed temperature and decreases by 1060 BTUH per 1000 CFM per degree below the listed temperature.

NOTE: KW RATING IS FOR OUTDOOR AND INDOOR UNITS.

HIGH CFM

Air Handlers	Coils	T.C.	S.C.	KW
AV/SV*60	-	0.97	0.95	1.02
AHX60	-	0.97	0.98	1.04
F4FV060	-	0.96	0.96	0.99
MV20D	FC/MC/PC60D	0.96	0.96	0.99
MV20D	UC60D	0.96	0.96	0.99
MV20D	FC/MC62D	1.00	1.00	1.00

Furnaces	Coils	T.C.	S.C.	KW
T*(8,L)X*C16	FC/PC60C	0.96	0.92	1.00
T*(8,L)X*C20	FC/PC60C	0.97	0.92	0.99
T*(8,L)X*C20	FC/MC/PC60D	0.97	0.92	0.99
T*9X*C20	FC/PC60C	0.94	0.91	1.03
T*9X*D20	FC/MC/PC60D	0.97	0.95	0.99
T*9X*C20	FC/MC/PC60D	0.97	0.93	0.99
T*(8,L)X*C20	FC/MC62D	0.98	0.96	1.00
T*9X*C20	FC/MC62D	0.97	0.94	0.99

Furnaces	Coils	T.C.	S.C.	KW
T*9X*D20	FC/MC62D	0.95	0.93	1.01
T*9X*D20	HD60	0.94	0.89	1.03
T*(8,L)X*C16	UC60C	0.94	0.90	1.00
T*(8,L)X*C20	UC60C	0.96	0.90	1.00
T*(8,L)X*C20	UC60D	0.96	0.90	1.00
T*9X*D20	UC60D	0.92	0.91	1.03
T*9X*C20	UC60C	0.95	0.91	0.99
T*9X*C20	UC60D	0.95	0.91	0.99
(C*9C/T*9V)*D20	FC/MC62D	0.97	0.94	1.02
(C*(8,L)C/T*8V)*C20	FC/PC60C	0.96	0.93	1.00
(C*9C/T*9V)*C20	FC/PC60C	0.96	0.93	1.02
(C*9C/T*9V)*D20	HC60	0.94	0.90	1.01
(C*(8,L)C/T*8V)*C20	HD60	0.97	0.93	1.00
(C*9C/T*9V)*C20	HD60	0.97	0.94	1.03
(C*9C/T*9V)*D20	HD60	0.96	0.92	1.02
(C*(8,L)C/T*8V)*C20	UC60C	0.94	0.89	1.00
(C*9C/T*9V)*C20	UC60C	0.93	0.89	1.02
(C*9C/T*9V)*D20	UC60D	0.94	0.89	1.01

NOTES