

# SUBMITTAL DATA SHEET

**R-410A SPLIT SYSTEM AIR CONDITIONERS  
2 THRU 5 TONS  
MODELS: 14.5 SEER TCGF24 THRU 60**

JOB NAME:			LOCATION:		
PURCHASER:			ORDER NO:		
ENGINEER:					
SUBMITTED TO:		FOR:	REF:	APPROVAL:	CONSTRUCTION:
SUBMITTED BY:			DATE:		
UNIT DESIGNATION:			SCHEDULE NO.	MODEL NO.	

## PRODUCT DATA

### Cooling Performance

Total Capacity \_\_\_\_\_ MBH

Outdoor Design Temp \_\_\_\_\_ °F

### Electrical Data

Power Supply \_\_\_\_ / \_\_\_\_ / \_\_\_\_

Compressor Ampacity \_\_\_\_\_ AMPs

Total Unit Ampacity \_\_\_\_\_ AMPs

Power Input Req \_\_\_\_\_ KW

Minimum Wire Size \_\_\_\_\_ AWG

Overcurrent Device

Fuses    Circuit Breaker

### Unit Weight

Unit Weight \_\_\_\_\_ LBS

## DIMENSIONS - INCHES

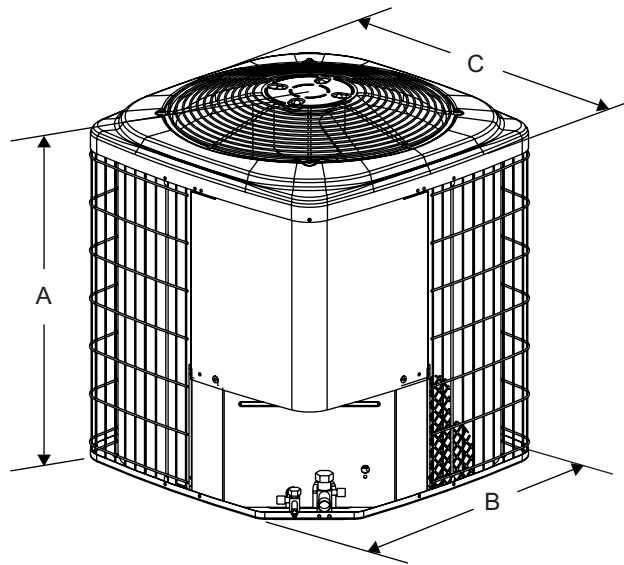

All dimensions are in inches. They are subject to change without notice. Certified dimensions will be provided upon request.



Unit Model	Dimensions (Inches)			Refrigerant Connection Service Valve Size	
	A <sup>1</sup>	B	C	Liquid	Vapor
24	28	29	29	3/8"	3/4"
30	36	29	29		
36	36	29	29		
42	34	33.6	33.6		7/8"
48	36	33.6	33.6		
60	40	33.6	33.6		

1. Including Fan Guard.
2. Adapter fitting required for 1-1/8" line set.

## FEATURES

- UL approval (units & accessories).
- CUL listed.
- Certified in accordance with the Unitary Small Equipment certification program, which the ARI Standard 210/240.
- 5-year limited parts warranty.
- 10-year limited warranty on the compressor.
- All aluminum coil
- Internally protected compressor.
- High Pressure Switch
- Propeller type fan.
- Durable construction.
- Pre-painted steel cabinet.
- Factory wired.
- Sweat refrigerant connections.
- Re-useable brass service valves.
- Easy access to electrical compartment.
- Liquid line filter dryer.
- Powder coated fan guard and coil guard.
- 18 gauge G90 galvanized formed base pan.

## CLEARANCES

Service Access	24 Inches
All Other Sides	10 Inches
Above Unit	48 Inches
Below Unit	0 Inches

## MATCHING AIR SIDE EQUIPMENT

Model No.  \_\_\_\_\_  
Submittal Form No.  \_\_\_\_\_

## FIELD INSTALLED ACCESSORIES

Off Cycle Timer (2TD08700124)  \_\_\_\_\_  
Thermostats  \_\_\_\_\_  
Blower Off Delay (2FD06700224)  \_\_\_\_\_  
Low Ambient Pressure Switch  \_\_\_\_\_

### NOTES:

---

---

---

---