

SUBMITTAL DATA SHEET



**ECHELON
R-410A SPLIT SYSTEM HEAT PUMP UNITS
15 SEER 2, 3, 4 & 5 TON
MODELS: HC5B024 THRU 060**

JOB NAME:			LOCATION:		
PURCHASER:			ORDER NO:		
ENGINEER:					
SUBMITTED TO:	FOR:	REF:	APPROVAL:	CONSTRUCTION:	
SUBMITTED BY:			DATE:		
UNIT DESIGNATION:		SCHEDULE NO.	MODEL NO.		

PRODUCT DATA

Cooling Performance

Total Capacity _____ MBH
Outdoor Design Temp _____ °F

Electrical Data

Power Supply ____ / ____ / ____
Compressor Ampacity _____ AMPs
Total Unit Ampacity _____ AMPs
Power Input Req _____ KW
Minimum Wire Size _____ AWG
Overcurrent Device
 Fuses Circuit Breaker

Unit Weight

Unit Weight _____ LBS

DIMENSIONS - INCHES

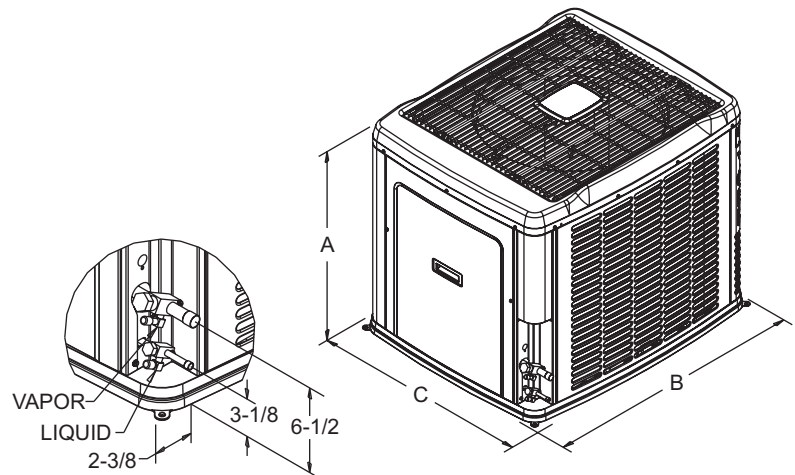

All dimensions are in inches. They are subject to change without notice. Certified dimensions will be provided upon request.

Unit Model	Dimensions (Inches)			Refrigerant Connection Service Valve Size	
	A	B	C	Liquid	Vapor
024	33-1/2	37	31	3/8"	3/4"
036	39-1/2	37	31		7/8"
048	39-1/2	37	31		7/8"
060	39-1/2	37	31		7/8"*

* Adapter fitting required for 1-1/8" line set.



FEATURES

- UL approval (units & accessories)
 - CSA listed and ARI certified
 - Copper tube/aluminum fin coil
 - Hi and Lo pressure switches standard
 - Durable construction
 - Powder-painted steel cabinet
 - Factory wired
 - R-410A total system charge (thru 15 ft. of lines)
 - Sweat refrigerant connections
 - Re-usable service valves
 - Slide down electrical compartment for easy access
 - Enhanced coil guard
 - Composite base pan
 - Isolated compressor compartment
 - Full service access panel
 - Comfort alert compressor protection
 - Whisperdrive system
 - Swept wing fan design
 - 5-year limited parts warranty
 - 10-year limited warranty on the compressor
 - Premium system warranty* - Limited Lifetime Compressor Warranty, 10 year parts warranty
- * Must be matched with an approved Coleman, coil and/or Air Handler.

MATCHING AIR SIDE EQUIPMENT

Model No. ()
 Submittal Form No. ()

FIELD INSTALLED ACCESSORIES

Dehumidification Control (2HU16700124) ()
 Thermostat ()
 Thermal Expansion Valve* ()
 Low Ambient Pressure Switch Kit ()
 Hard Start Kit ()

* Must be installed for proper performance.

(Refer to Technical Guide for detailed specifications on the unit and its accessories.)

CLEARANCES

Front of Unit..... 24 inch
 All Other Sides..... 12 inch
 Above Unit 60 inch
 Below Unit..... 0 inch

*Must be installed for proper performance.

NOTES:
